

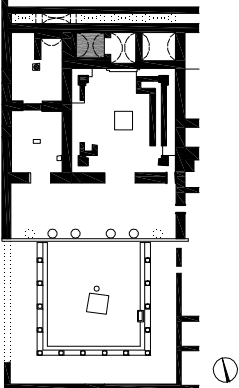

1 Raum 4. Westwand

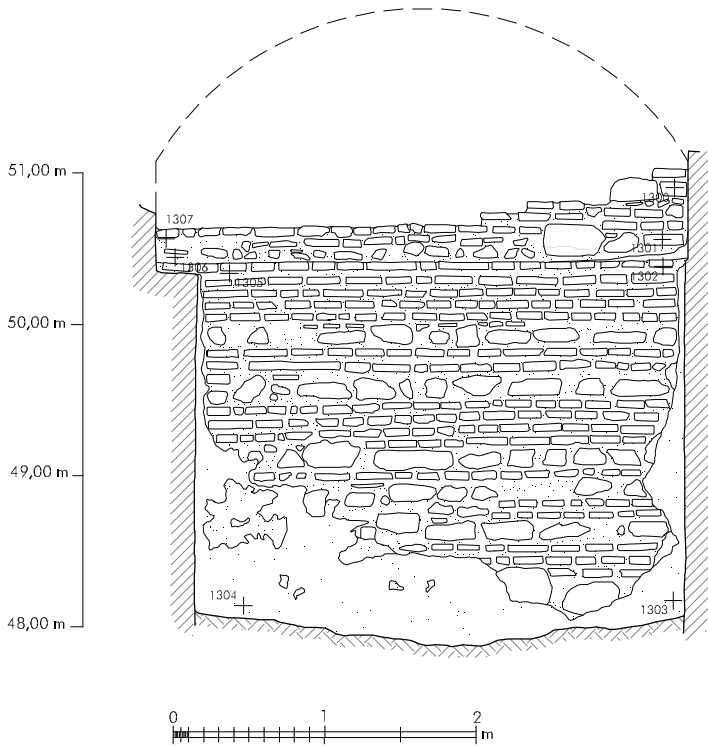

PRYTANEION
 Raum 4 - Westwand
 gezeichnet
 P. Mayrhofer
 grafische Bearbeitung
 L. Zabraná

2 Raum 4. Westwand (1:50)



1 Raum 4. Pfeiler der Ostwand

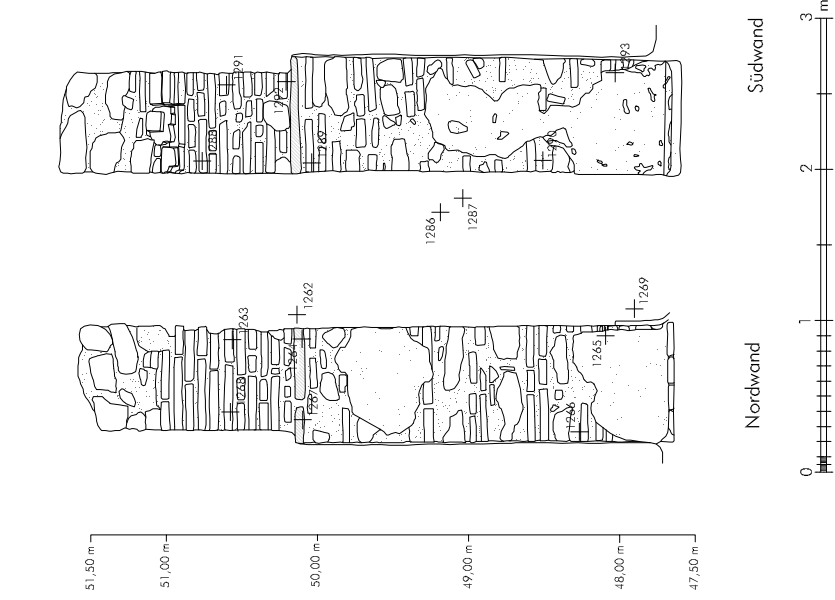
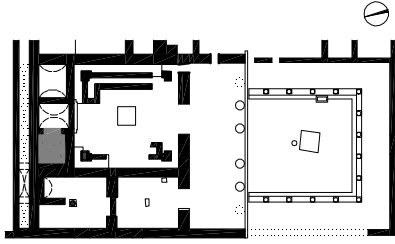

PRYTANEION
Pfeiler zwischen Raum 3 und 4
gezeichnet
P. Mayrhofer
grafische Bearbeitung
L. Zabara

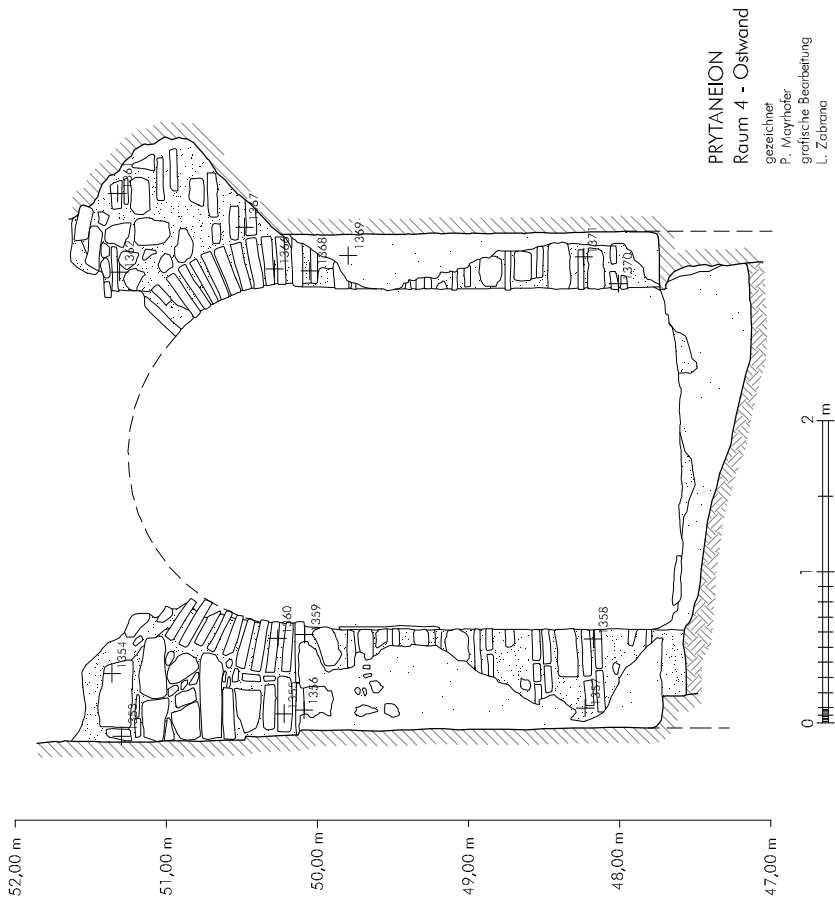

PRYTANEION
Raum 4 - Ostwand
gezeichnet
P. Mayrhofer
grafische Bearbeitung
L. Zabara

1 Raum 4. Pfeiler der Ostwand (1:50)



1 Raum 3 von Osten



2 Raum 3. Süd-
wand

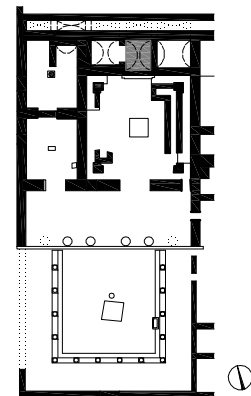
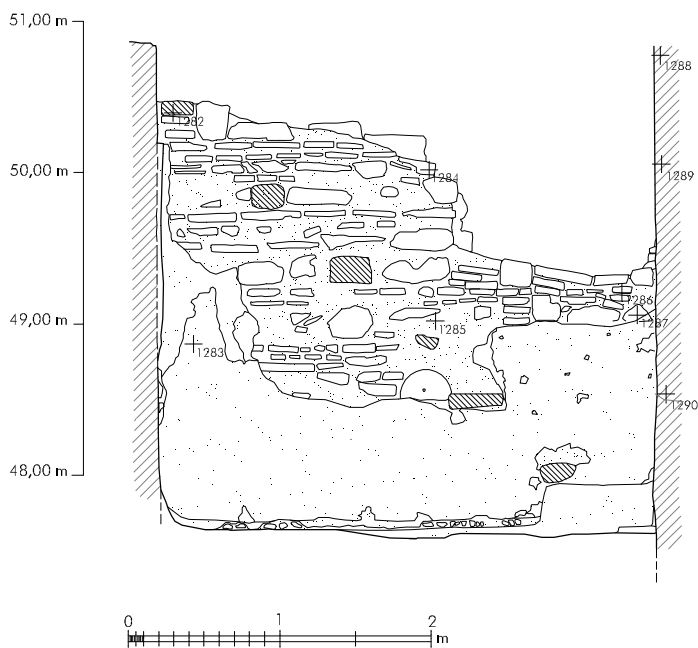

PRYTANEION
Raum 3 - Südwall
gezeichnet
P. Mayrhofer
grafische Bearbeitung
L. Zabrana

3 Raum 3. Südwall (1:50)



1 Raum 3. Pfeiler der Westwand

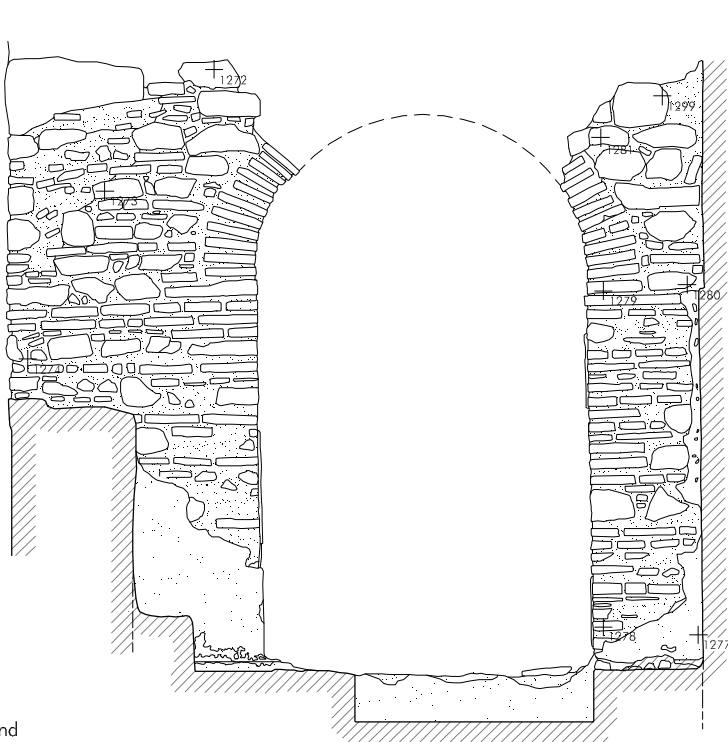

PRYTANEION
Raum 3 - Westwand
gezeichnet
P. Mayrhofer
grafische Bearbeitung
L. Zabara

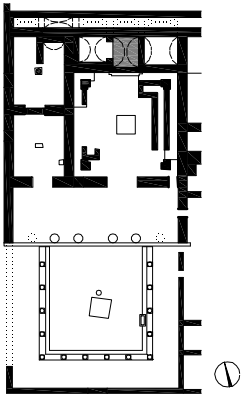
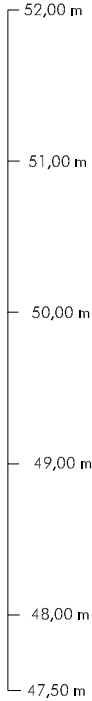
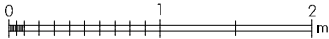

2 Raum 3. Pfeiler der Westwand (1:50)



1 Raum 3. Nordwand oberer Teil



2 Raum 3. Nordwand unterer Teil

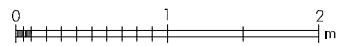
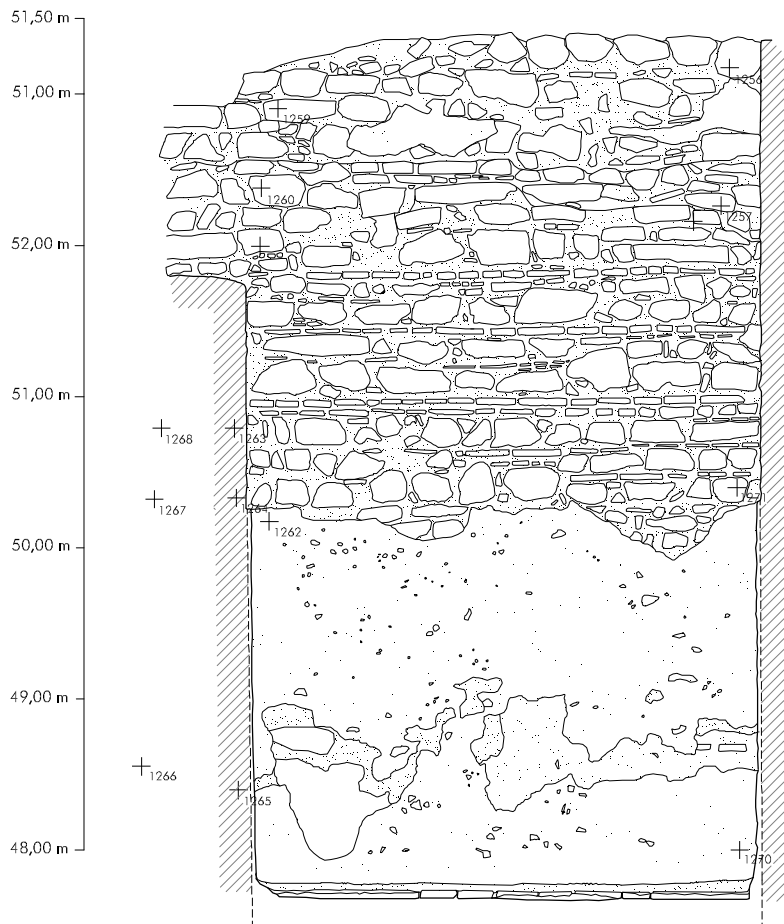
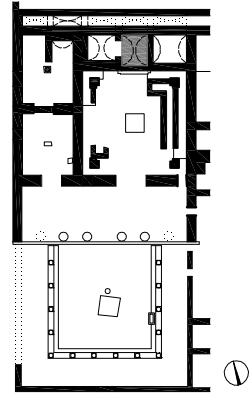

PRYTANEION
Raum 3 - Nordwand
gezeichnet
P. Mayrhofer
grafische Bearbeitung
L. Zabraná

1 Raum 3. Nordwand (1:50)



1 Raum 3.
Ostwand

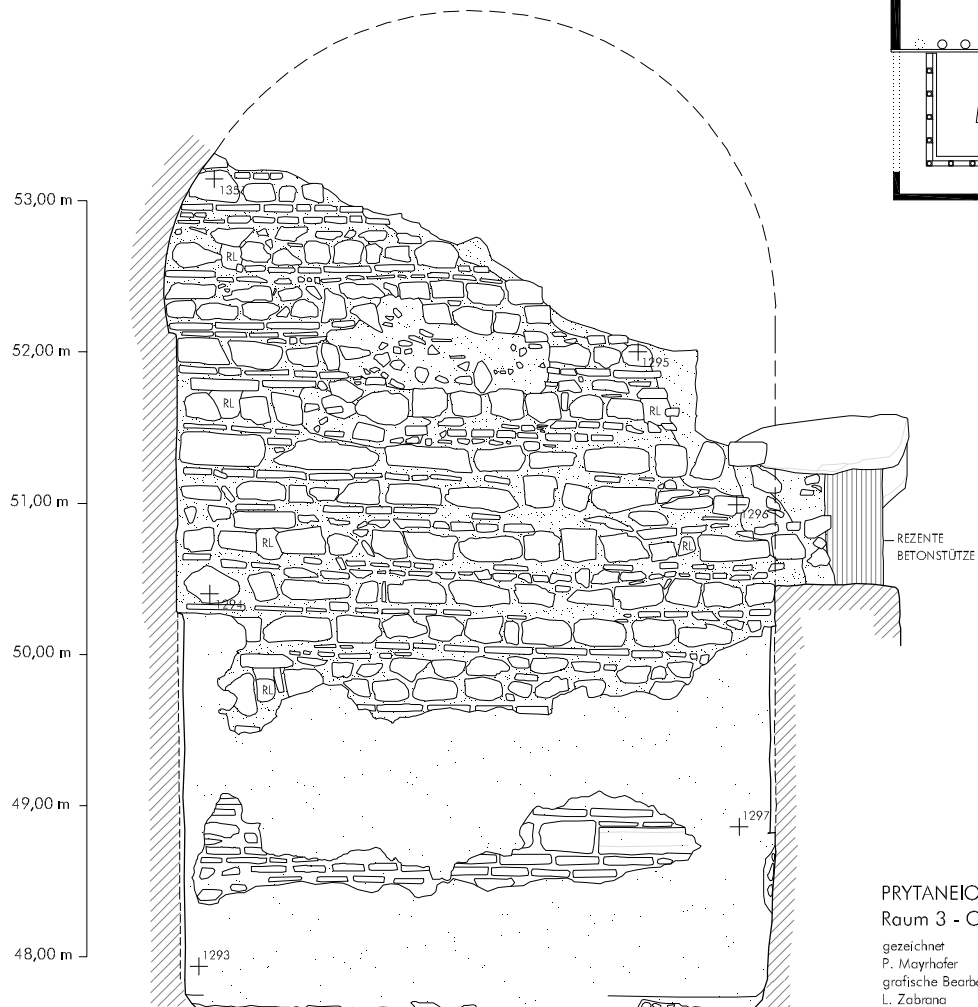
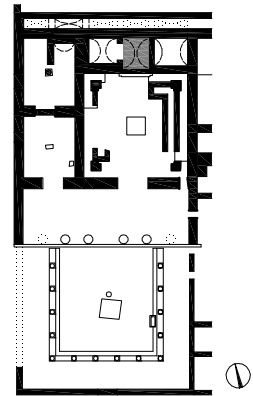

PRYTANEION
Raum 3 - Ostwand
gezeichnet
P. Mayrhofer
grafische Bearbeitung
L. Zabrano

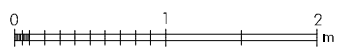

2 Raum 3. Ostwand (1:50)



1 Raum 3. Ausfluss des Wasserreservoirs



2 »Hestiasaak«. Sekundäre Öffnung in Nordwand zur Wasserentnahme



3 Raum 2 von Westen



1 Raum 2.
Südwand

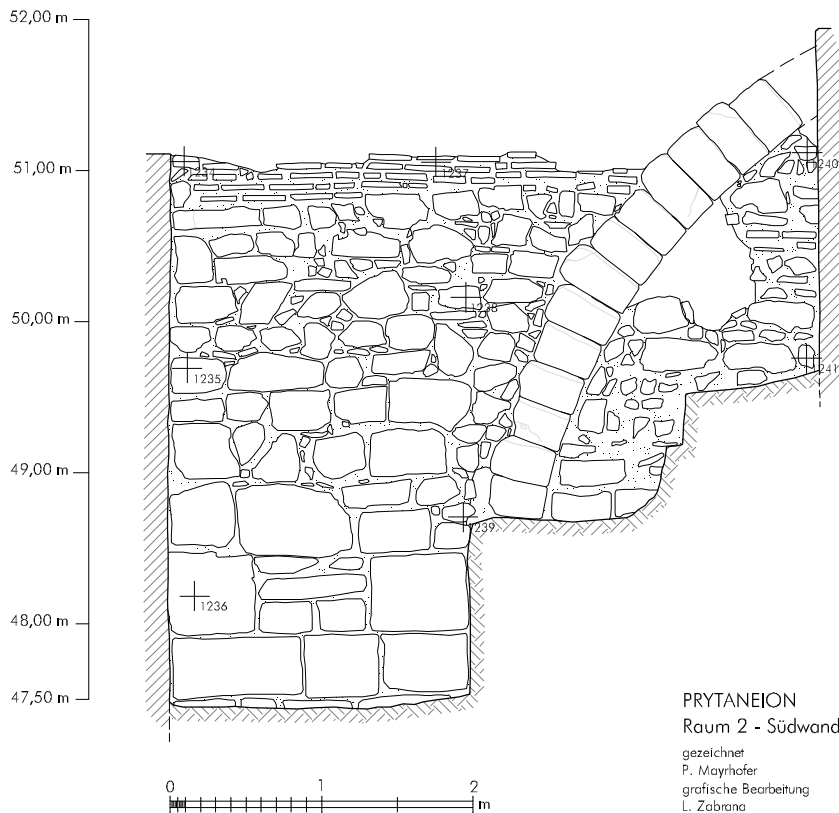

PRYTANEION
Raum 2 - Südwand
gezeichnet
P. Mayrhofer
grafische Bearbeitung
L. Zabrana

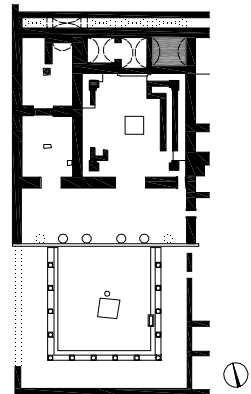

2 Raum 2. Südwand (1:50)

1 Raum 2.
Westwand

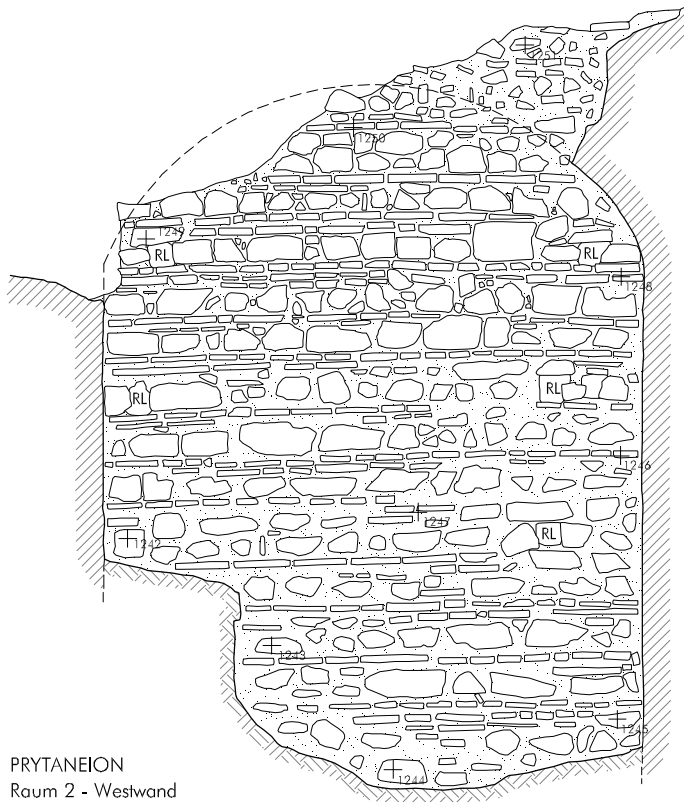

PRYTANEION
Raum 2 - Westwand
gezeichnet
P. Mayrhofer
grafische Bearbeitung
L. Zabranca

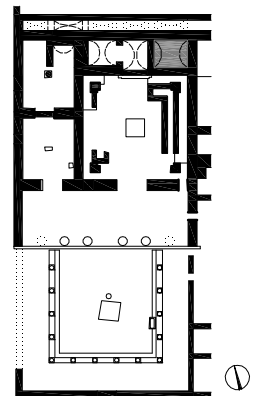
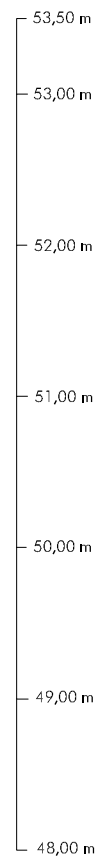
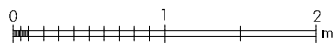

2 Raum 2. Westwand (1:50)



1 Raum 2. Nordwand oberer Teil

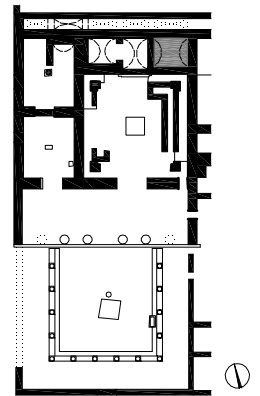
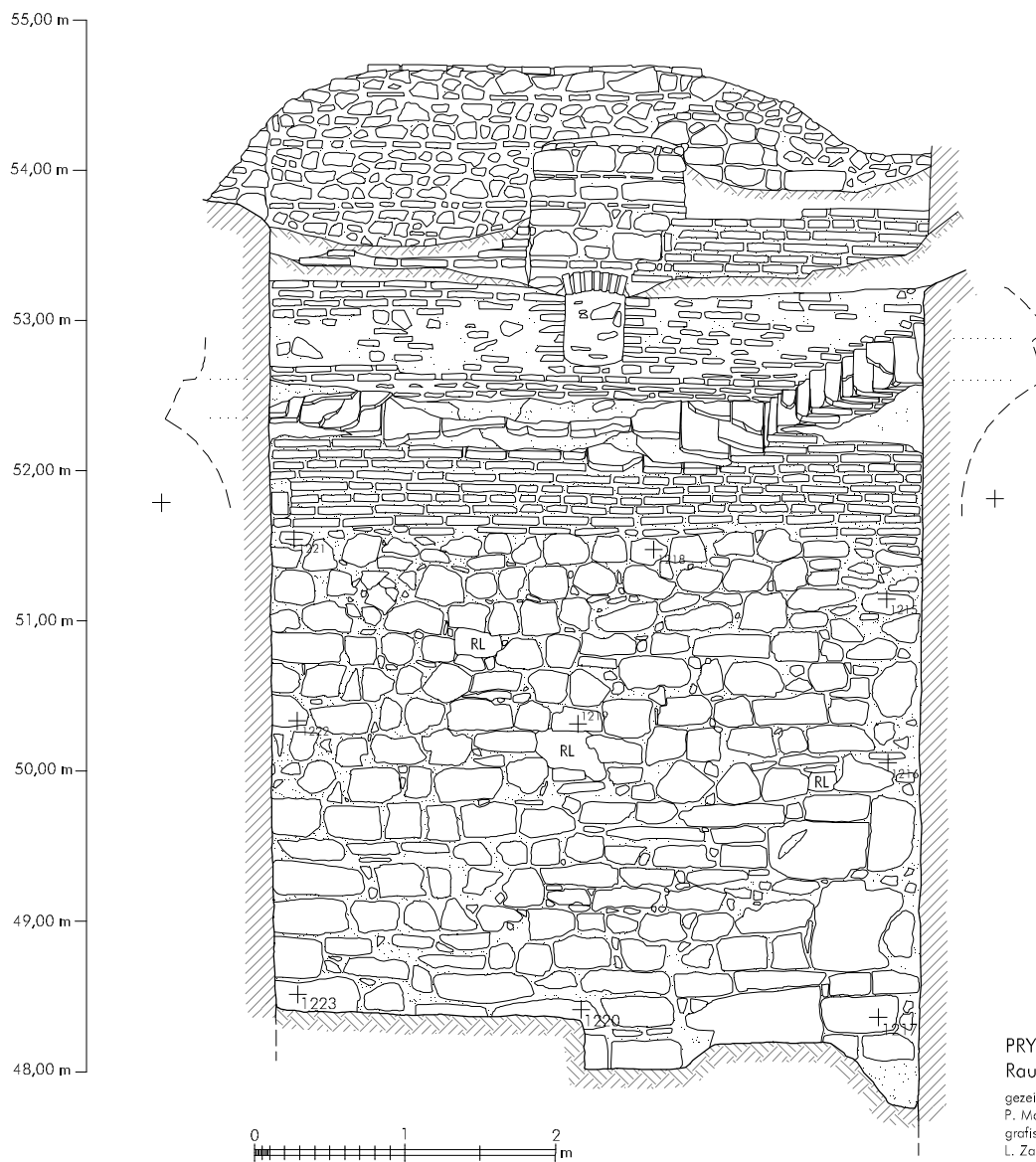

PRYTANEION
Raum 2 - Nordwand
gezeichnet
P. Mayrhofer
grafische Bearbeitung
L. Zabrana

2 Raum 2. Nordwand (1:50)

1 Raum 2. Ostwand

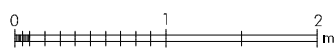
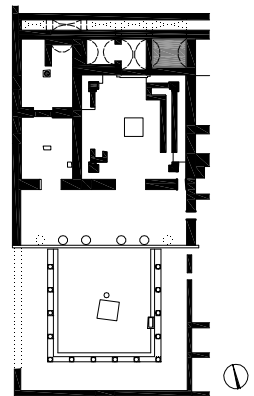
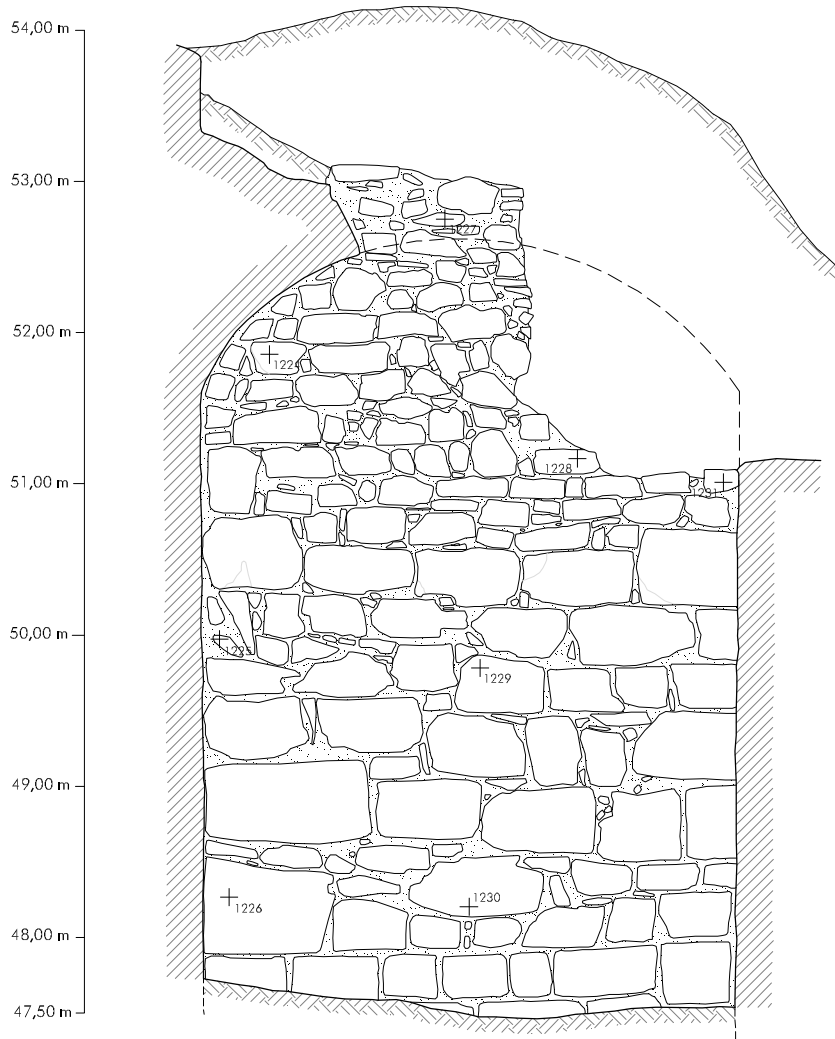

PRYTANEION
Raum 2 - Ostwand
gezeichnet
P. Mayrhofer
grafische Bearbeitung
L. Zabranca

2 Raum 2. Ostwand (1:50)



1 Raum 2. Ziegelbogen in Sturzlage



2 Raum 2. Ende der 1960er Jahre bereits weitgehend zerstörter Ziegelbogen

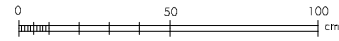
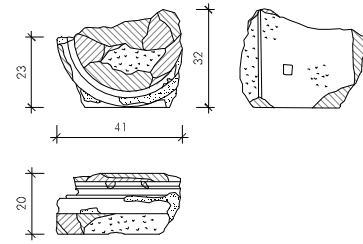
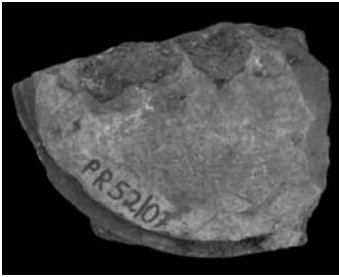

PRYTANEION
PR 52/07
ATTISCHE BASIS
gezeichnet
B. Stark
grafische Bearbeitung
L. Zabrana

1 Attische Basis A 32

2 Attische Basis A 32 (1:25)

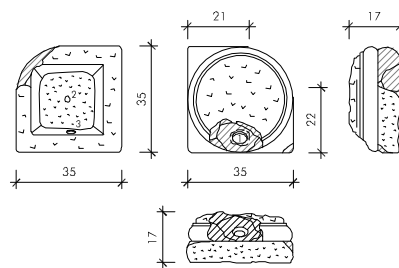
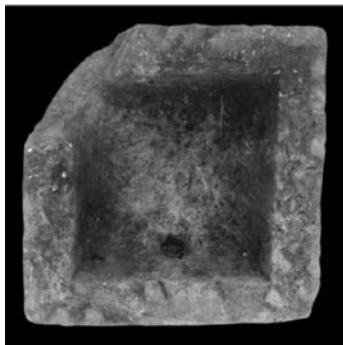
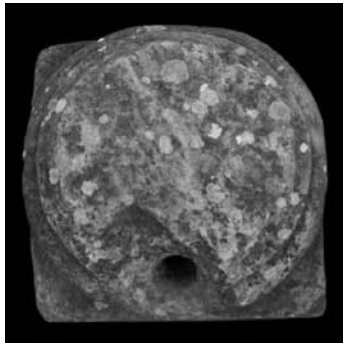

T 1: 10 cm, r 1: 17,5 cm
T 2: 7 cm, r 2: 15,5 cm
T 3: 3 cm, r 3: 14,5 cm

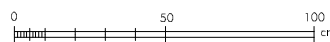

PRYTANEION
PR 53/07
ATTISCHE BASIS
gezeichnet
B. Stark
grafische Bearbeitung
L. Zabrana

4 Attische
Basis A 33
(1:25)

3 Attische Basis A 33

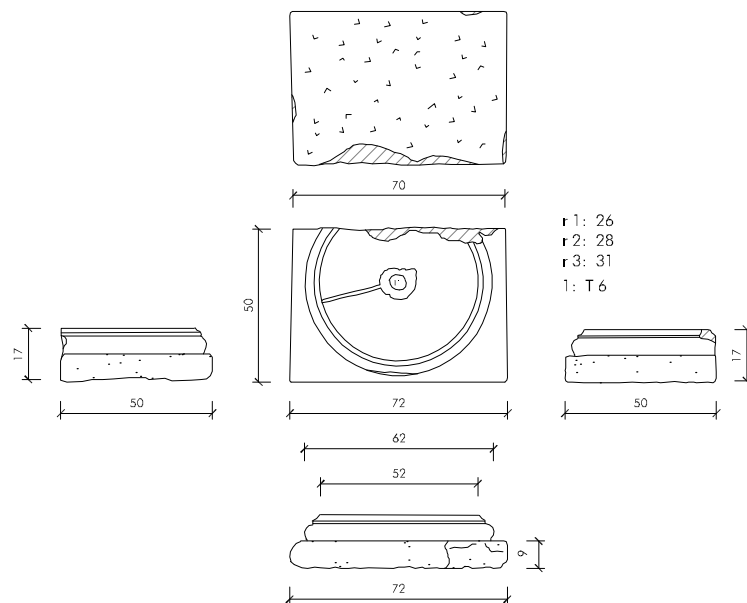
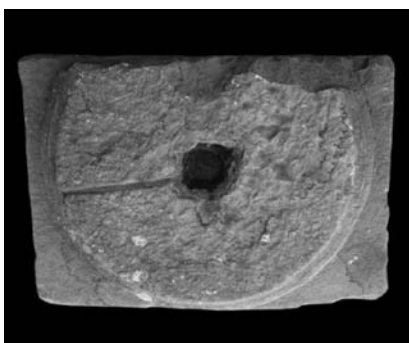

r 1: 26
r 2: 28
r 3: 31
1: T 6

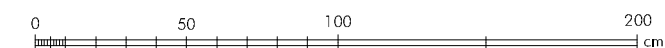

PRYTANEION
PR 31/07
ATTISCHE BASIS
gezeichnet
B. Stark
grafische Bearbeitung
L. Zabrana

5 Attische Basis A 34

6 Attische Basis A 34 (1:25)



1 Attische Basis A 35

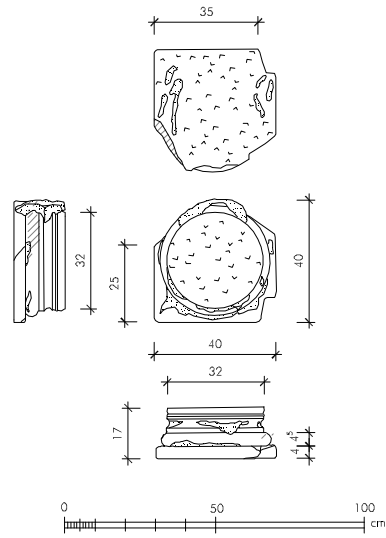

PRYTANEION
PR 50/07
ATTISCHE BASIS
gezeichnet
B. Stark
grafische Bearbeitung
L. Zabrana

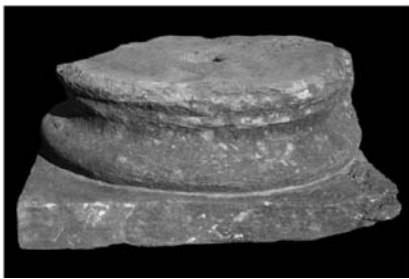
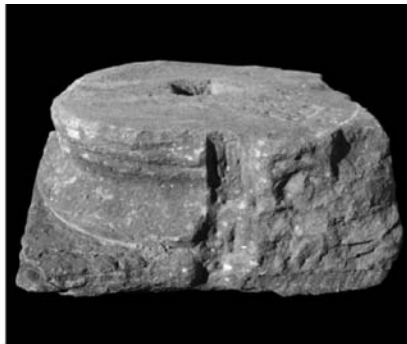
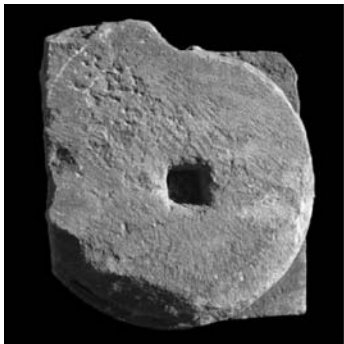

3 Attische Basis einer Dreiviertelsäule A 36

2 Attische Basis A 35 (1:25)

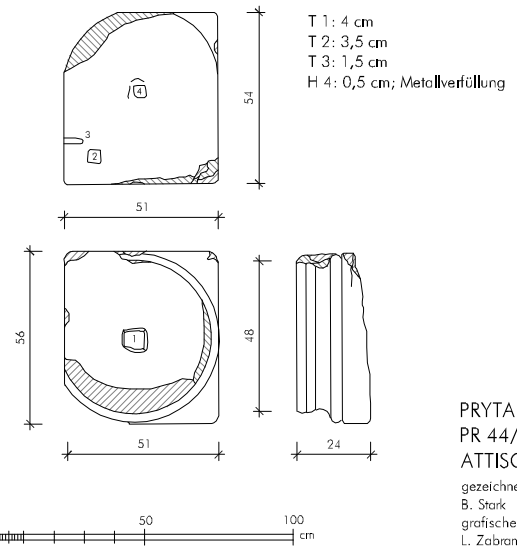

PRYTANEION
PR 44/07
ATTISCHE BASIS
gezeichnet
B. Stark
grafische Bearbeitung
L. Zabrana

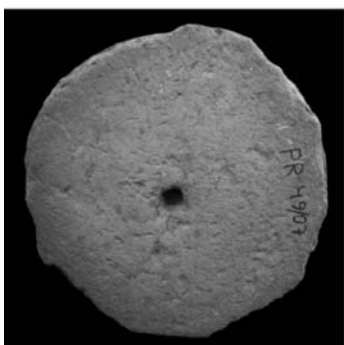
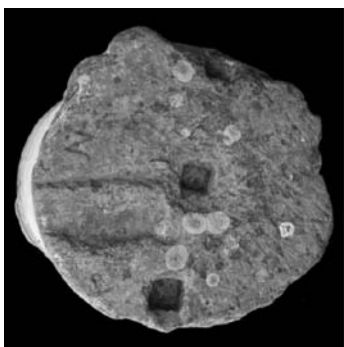

5 Rundbasis A 37

4 Attische Basis einer Dreiviertelsäule A 36 (1:25)

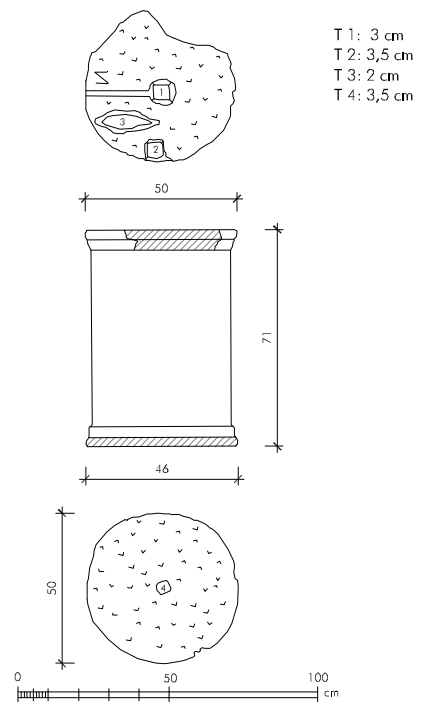

PRYTANEION
PR 49/07
RUNDBASIS
gezeichnet
B. Stark
grafische Bearbeitung
L. Zabrana

6 Rundbasis A 37 (1:25)

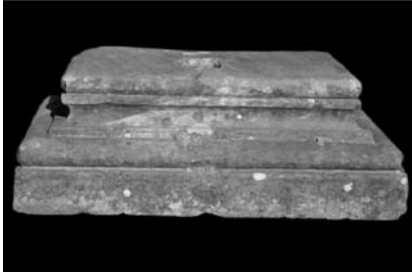
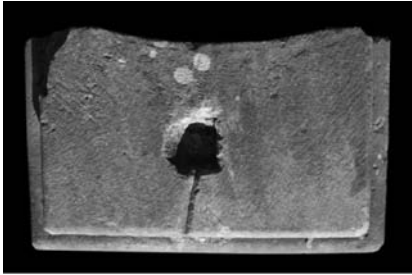

1 Pfeiler-/Pilasterbasis A 38

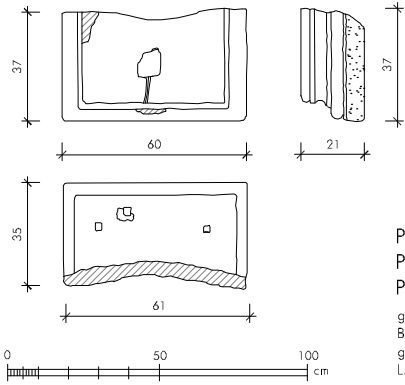

PRYTANEION
PR 30/07
PFEILER-/PILASTERBASIS
gezeichnet
B. Stark
grafische Bearbeitung
L. Zabrana

2 Pfeiler-/Pilasterbasis A 38 (1:25)

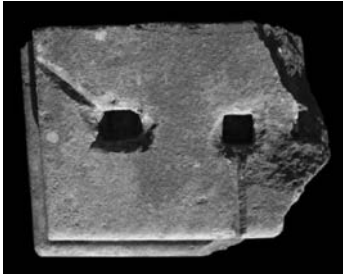

3 Pfeiler-/Pilasterbasis A 39

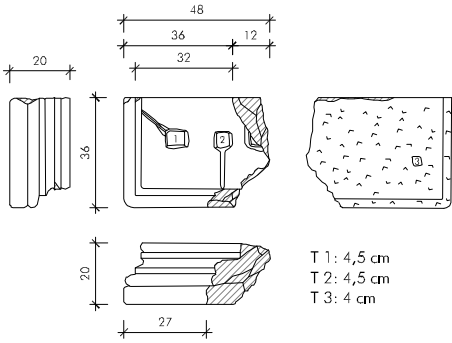

T 1: 4,5 cm
T 2: 4,5 cm
T 3: 4 cm



PRYTANEION
PR 43/07
PFEILER-/PILASTERBASIS
gezeichnet
B. Stark
grafische Bearbeitung
L. Zabrana

4 Pfeiler-/Pilasterbasis A 39 (1:25)



5 Pfeiler A 40

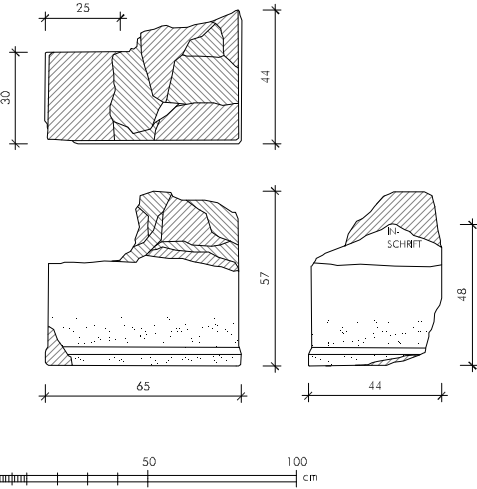

PRYTANEION
PR 45/07
PFEILER
gezeichnet
B. Stark
grafische Bearbeitung
L. Zabrana

6 Pfeiler A 40 (1:25)