

1 Zahnschnittgeison mit Sima A 41

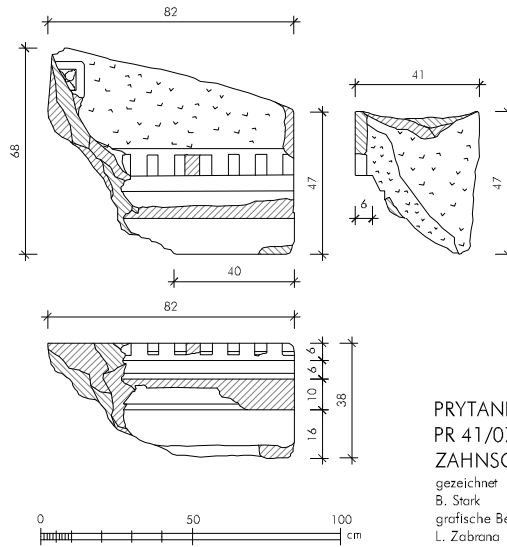

PRYTANEION
PR 41/07
ZAHNSCHNITTGEISON
gezeichnet
B. Stark
grafische Bearbeitung
L. Zabrana

2 Zahnschnittgeison mit Sima A 41 (1:25)

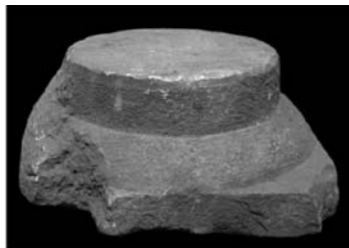
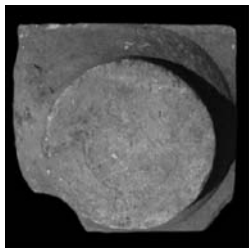

3 Dorisches Kapitell A 42

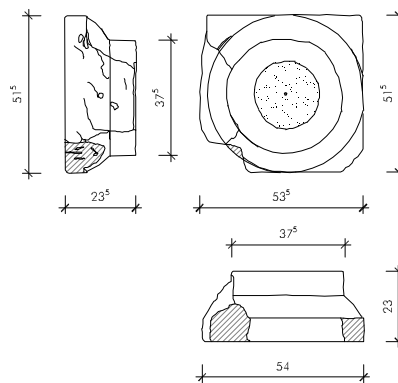

PRYTANEION
PR 48/07
DORISCHES KAPITELL
gezeichnet
N. High
grafische Bearbeitung
L. Zabrana

4 Dorisches Kapitell A 42 (1:25)

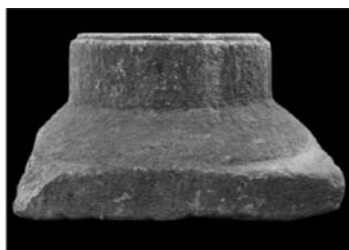
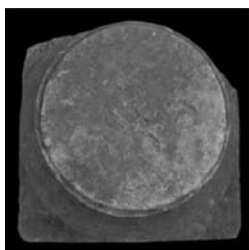

5 Tuskanisches Kapitell A 43

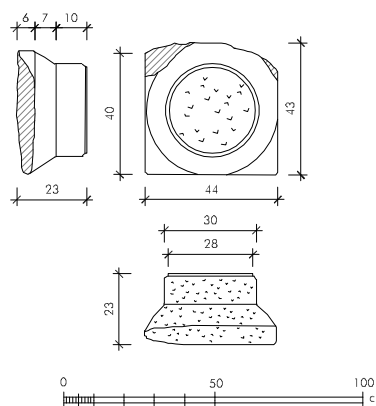

PRYTANEION
PR 51/07
TUSKANISCHES KAPITELL
gezeichnet
B. Stark
grafische Bearbeitung
L. Zabrana

6 Tuskanisches Kapitell A 43 (1:25)

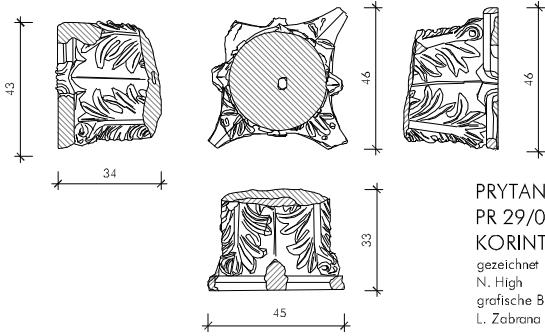
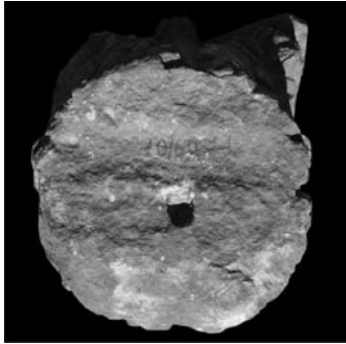
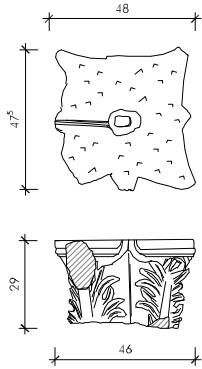
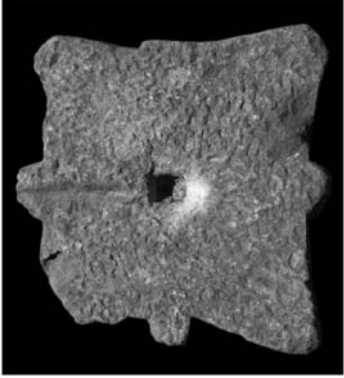

PRYTANEION
PR 29/07
KORINTHISCHES KAPITELL
gezeichnet
N. High
grafische Bearbeitung
L. Zabrana

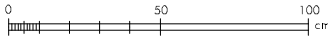

1 Korinthisches Kapitell A 44

2 Korinthisches Kapitell A 44 (1:25)

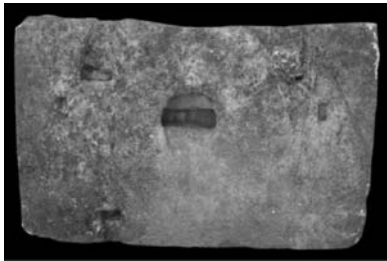

3 Pilasterkapitell A 45

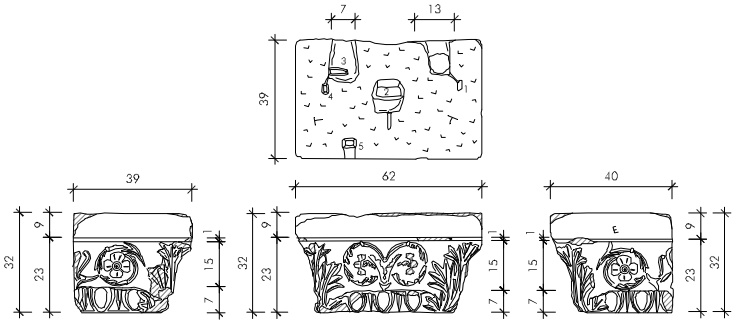

PRYTANEION
PR 30/07
PILASTERKAPITELL
gezeichnet
B. Stark
grafische Bearbeitung
L. Zabrana

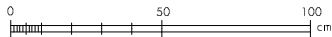
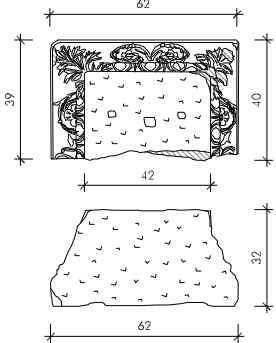

4 Pilasterkapitell A 45 (1:25)

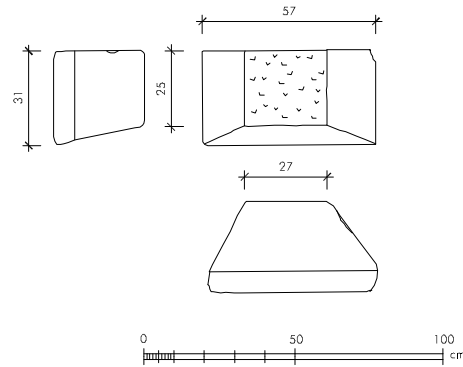
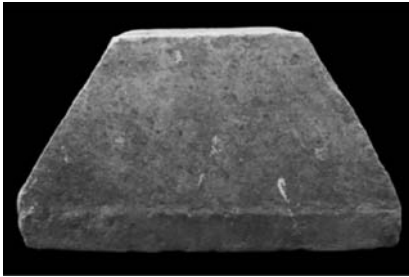
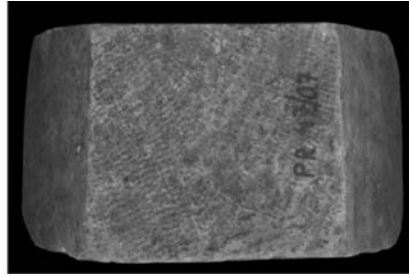
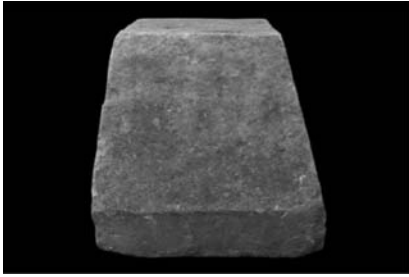

1 Kämpfer A 46

2 Kämpfer A 46 (1:25)

PRYTANEION
PR 47/07
KÄMPFER
gezeichnet
B. Stark
grafische Bearbeitung
L. Zabrona

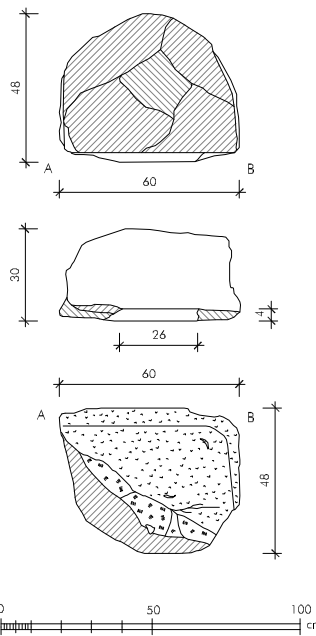

3 Sockel Ehrenbasis? SK 16

4 Sockel Ehrenbasis? SK 16 (1:25)

PRYTANEION
PR 46/07
SOCKEL EHRENBASIS
gezeichnet
B. Stark
grafische Bearbeitung
L. Zabrona

PRYTANEION
SONDAGEN 2007-2008

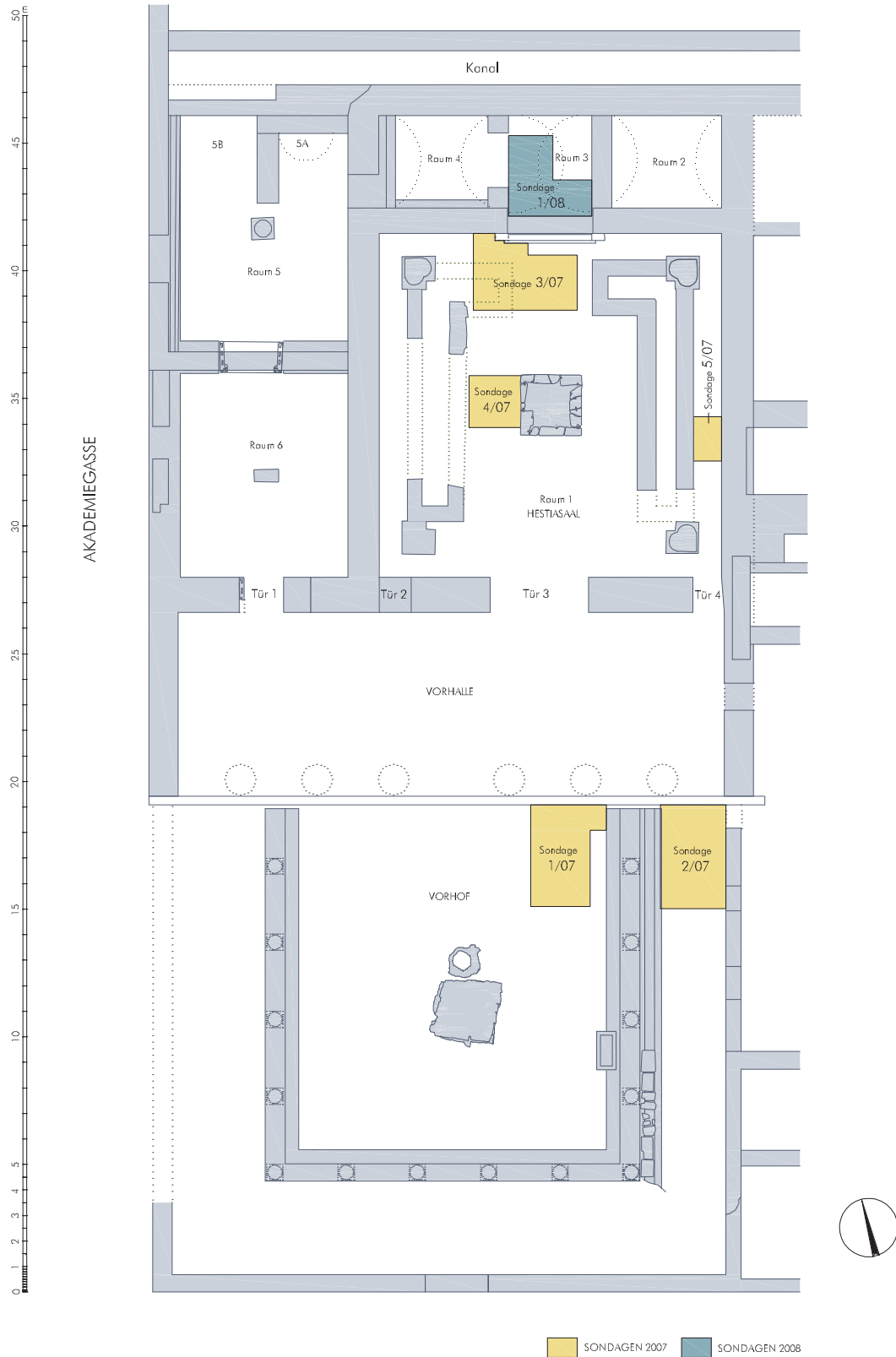

SONDAGEN 2007 SONDAGEN 2008

1 Prytaneion. Generalisierter Grundriss mit Sondagenplan 2007–2008 (1:250)



1 Schnitt 1/07. Ausgangssituation von Süden



2 Schnitt 1/07. Endsituation von Süden



1 Schnitt 1/07.
Endsituation
von Westen



2 Schnitt 1/07.
Westprofil



3 Schnitt 1/07.
Nordprofil

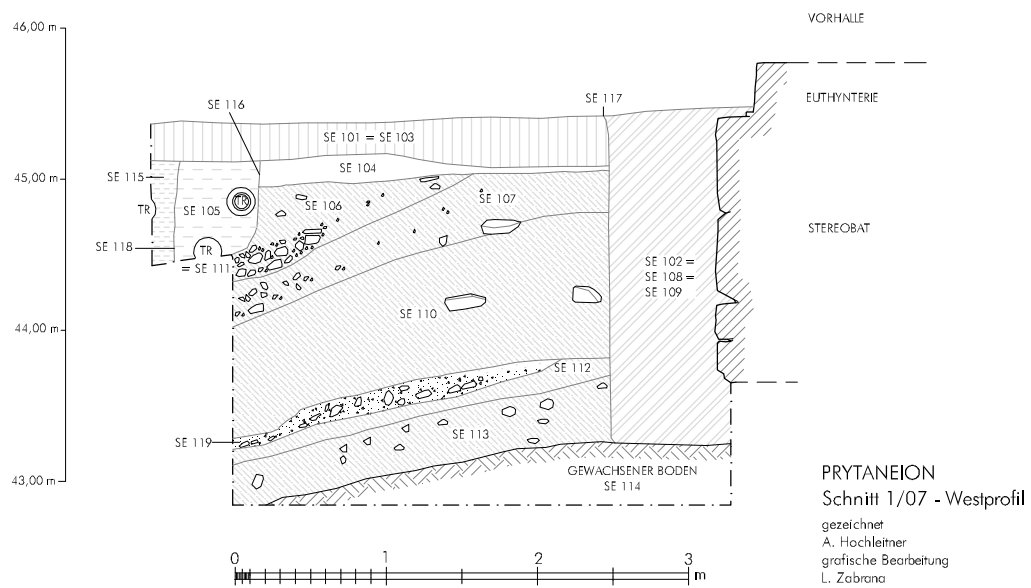
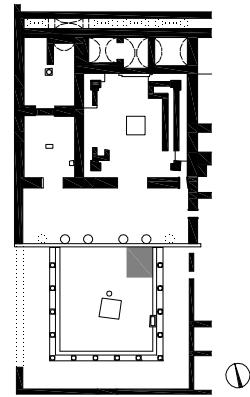

1 Schnitt 1/07. Westprofil (1:50)

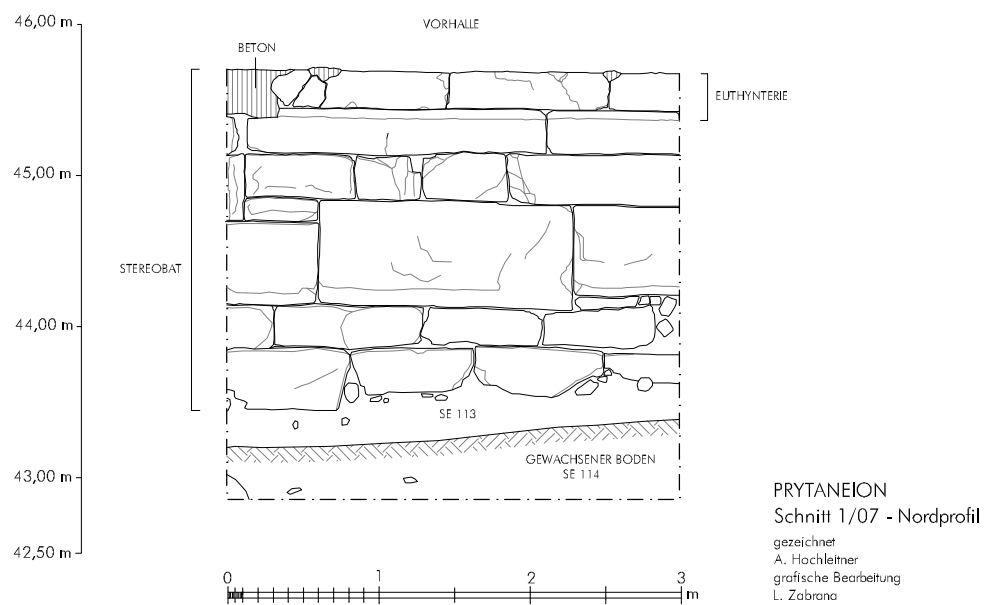

2 Schnitt 1/07. Nordprofil (1:50)



1 Schnitt 2/07.
Ausgangs-
situation von
Süden



2 Schnitt 2/07.
Kanal SE
204



3 Schnitt 2/07. Endsituation
von Süden



1 Schnitt 2/07. Südprofil



2 Schnitt 2/07. Ostprofil



3 Schnitt 2/07. Nordprofil

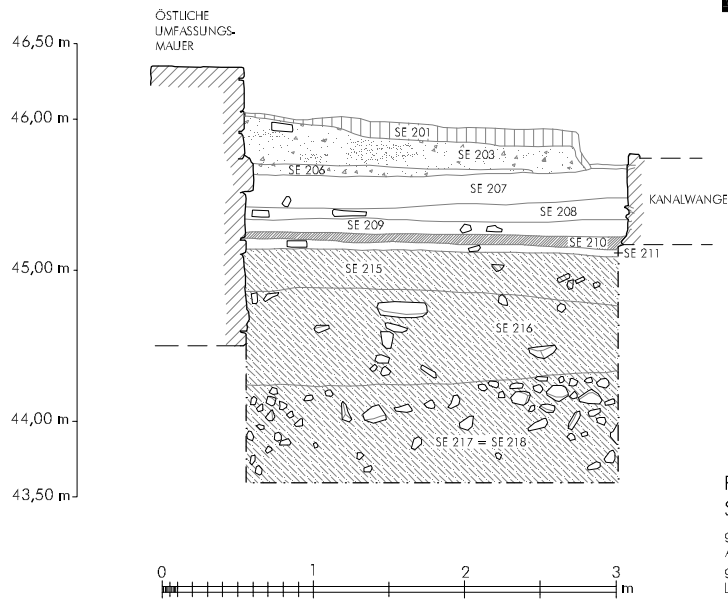
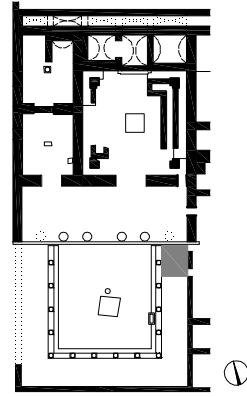

PRYTANEION
Schnitt 2/07 - Südprofil
gezeichnet
A. Hochleitner
grafische Bearbeitung
L. Zabrona

1 Schnitt 2/07. Südprofil (1:50)

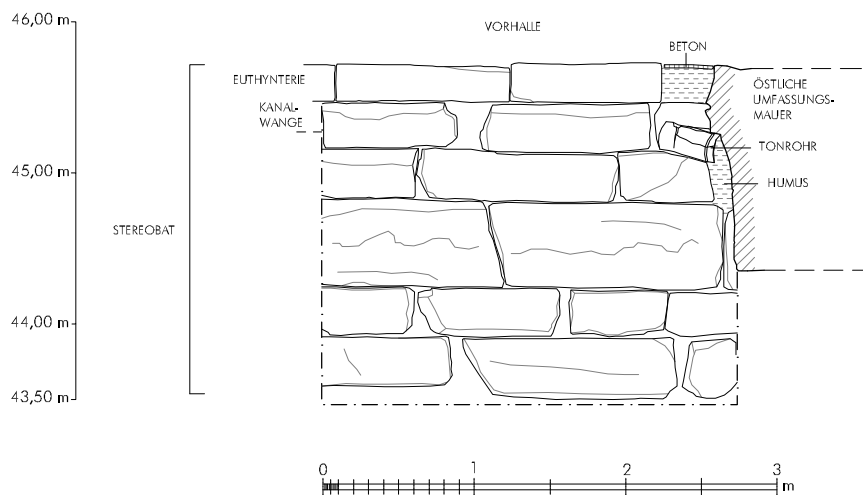

PRYTANEION
Schnitt 2/07 - Nordprofil
gezeichnet
A. Hochleitner
grafische Bearbeitung
L. Zabrona

2 Schnitt 2/07. Nordprofil (1:50)



1 Schnitt 3/07. Ausgangssituation von Süden



2 Schnitt 3/07. Fundament und Estrich (SE 303, SE 304) des Marmorplattenbodens



1 Schnitt 3/07. Endsituation von Süden

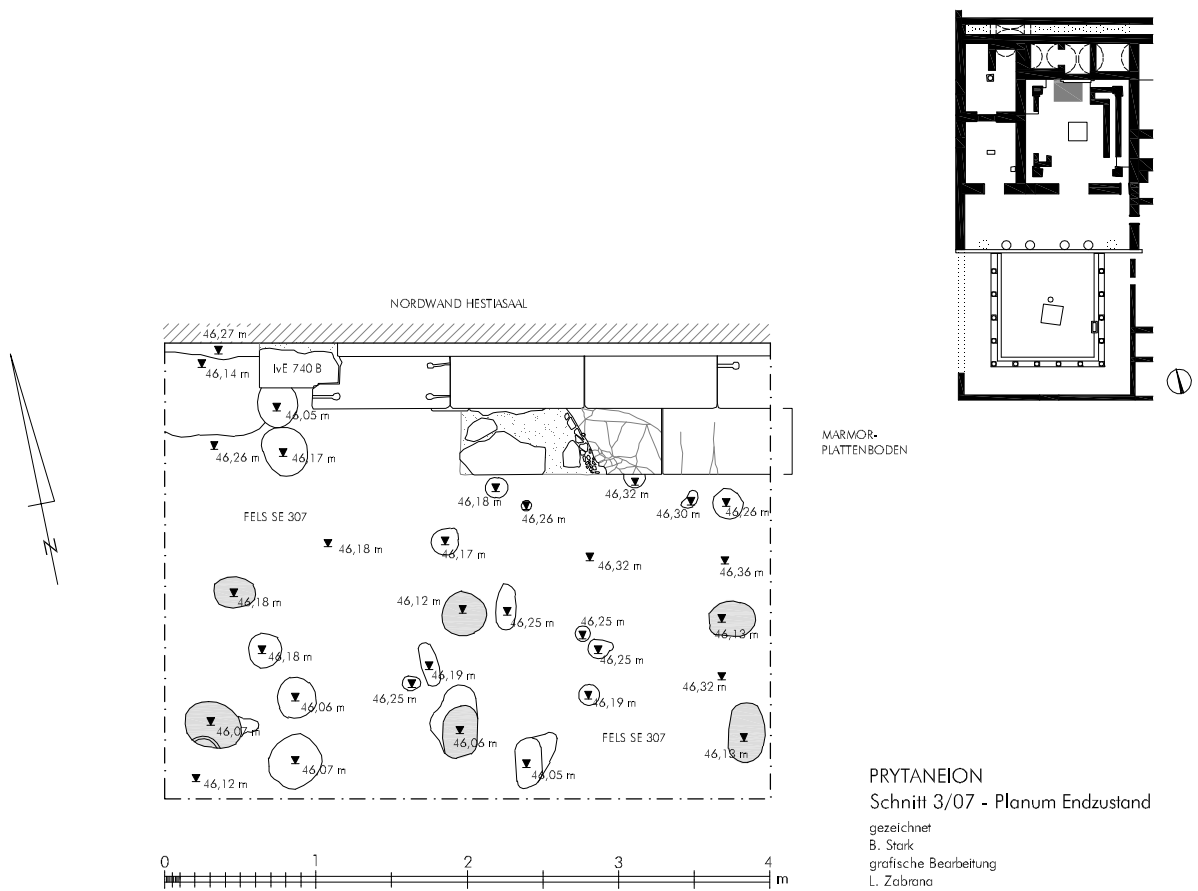

2 Schnitt 3/07. Planum Endzustand (1:50)



1 Schnitt 3/07. Ostprofil

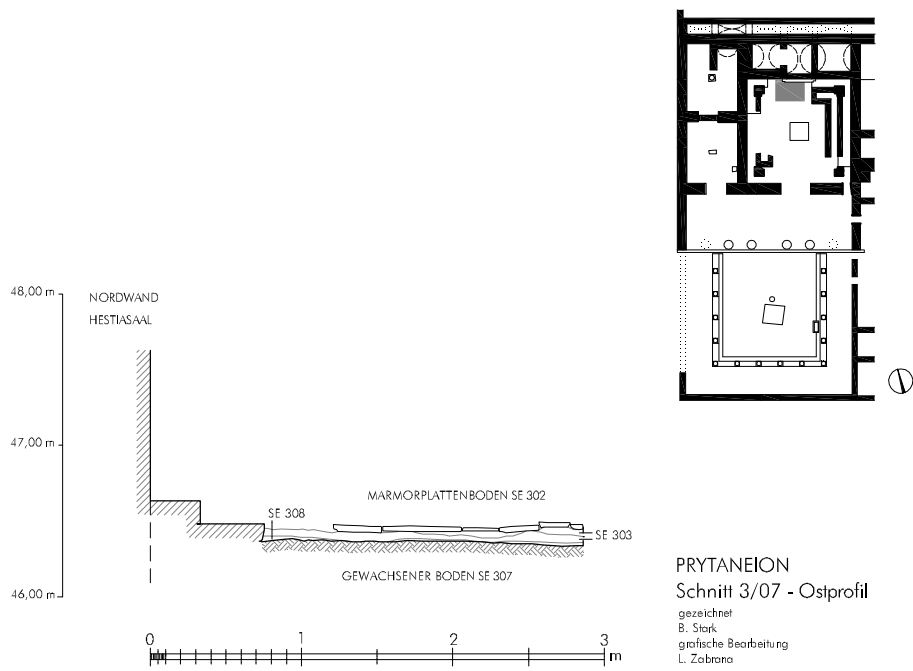

2 Schnitt 3/07. Ostprofil (1:50)



1 Schnitt 4/07. Ausgangssituation von Osten



2 Schnitt 4/07. Fundament und Estrich (SE 402, SE 403) des Marmorplattenbodens



3 Schnitt 4/07. Kalkgrube SE 407



1 Schnitt 4/07. Endsituation von Osten



2 Schnitt 4/07. Ostprofil



3 Schnitt 4/07. Südprofil

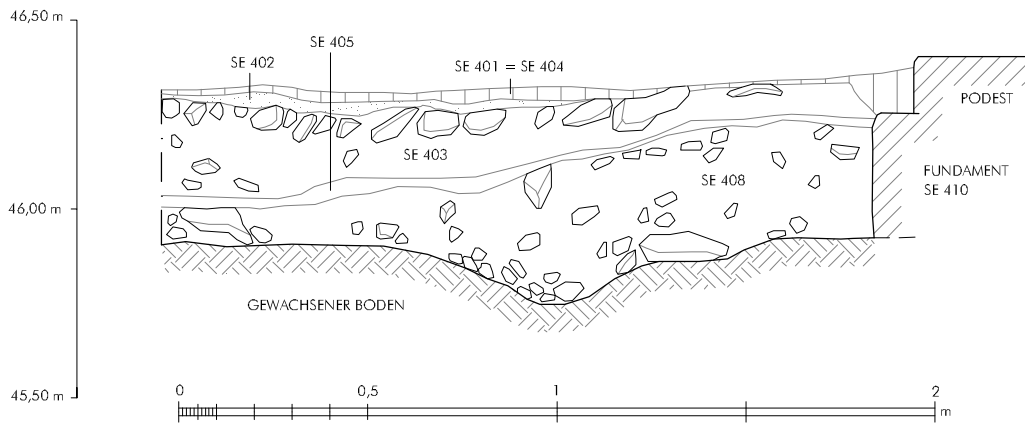

1 Schnitt 4/07. Nordprofil (1:20)

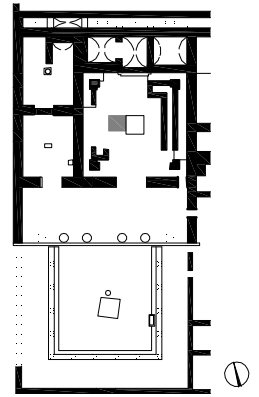

PRYTANEION
Schnitt 4/07 - Nordprofil
gezeichnet
B. Stark
grafische Bearbeitung
L. Zabrana

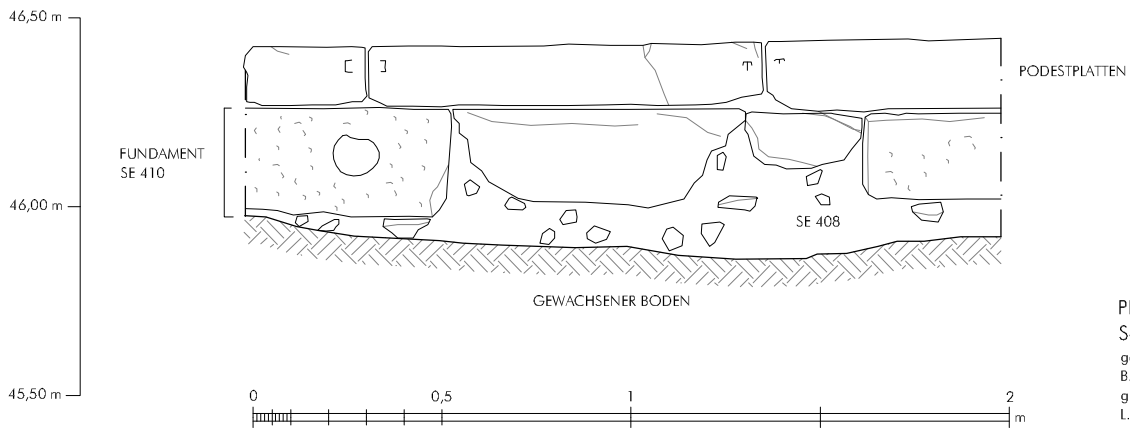

2 Schnitt 4/07. Ostprofil (1:20)

PRYTANEION
Schnitt 4/07 - Ostprofil
gezeichnet
B. Stark
grafische Bearbeitung
L. Zabrana

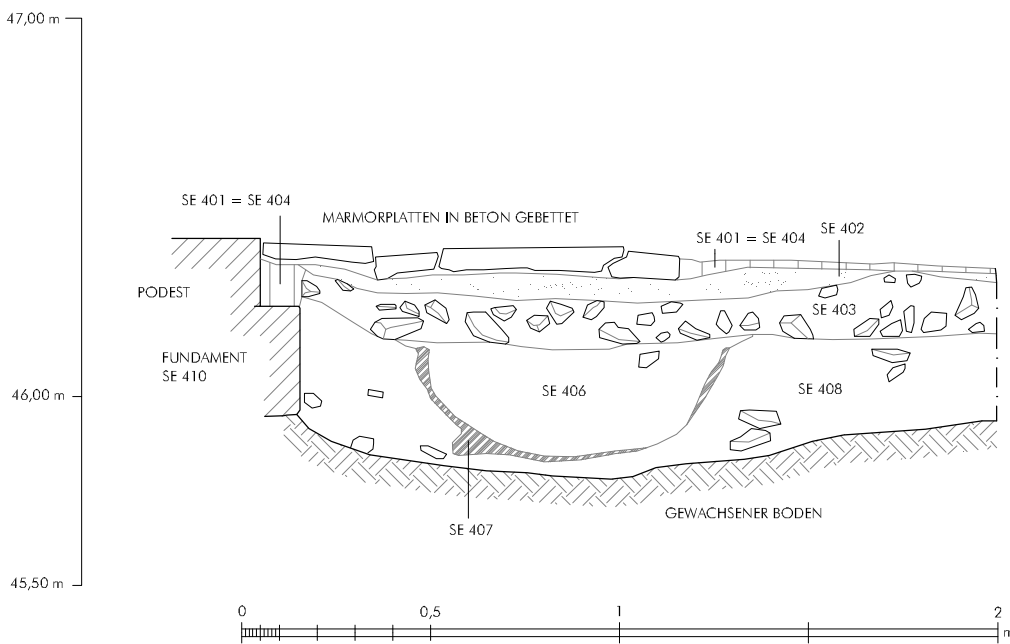

3 Schnitt 4/07. Südprofil (1:20)

PRYTANEION
Schnitt 4/07 - Südprofil
gezeichnet
B. Stark
grafische Bearbeitung
L. Zabrana



1 Schnitt 5/07. Ausgangssituation von Westen



2 Schnitt 5/07. Endsituation von Westen