

Einfache flache Schalen (1)

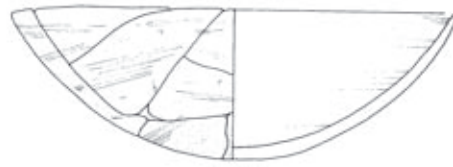

8900E

Schalen mit geschwungener Kontur, klein (2)

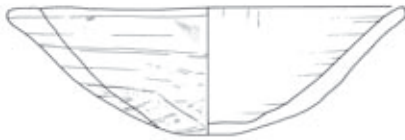

8889P



8900S

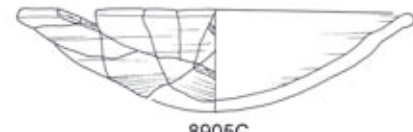

8905C



8565C

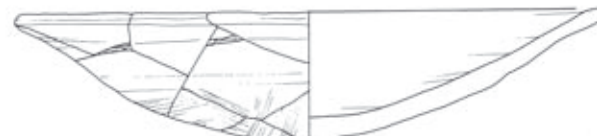

8890S

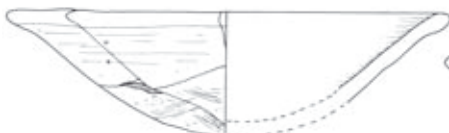

8558S

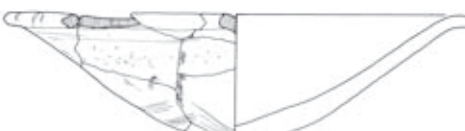

8558R

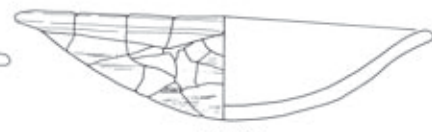

8892Q

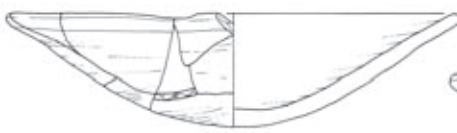

8913O



8899S

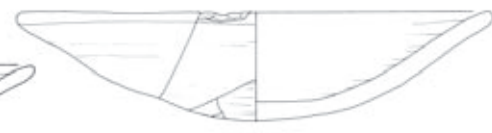

8899O



8565B

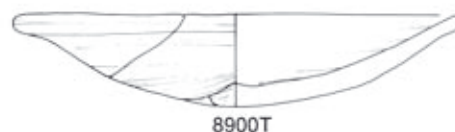

8900T



8565G



8928F

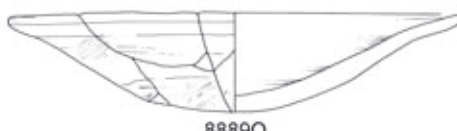

8889Q



8558J



8899N

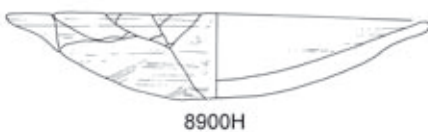

8900H



8900G



8643D

Abb. T1

## Schalen mit geschwungener Kontur, groß (3)

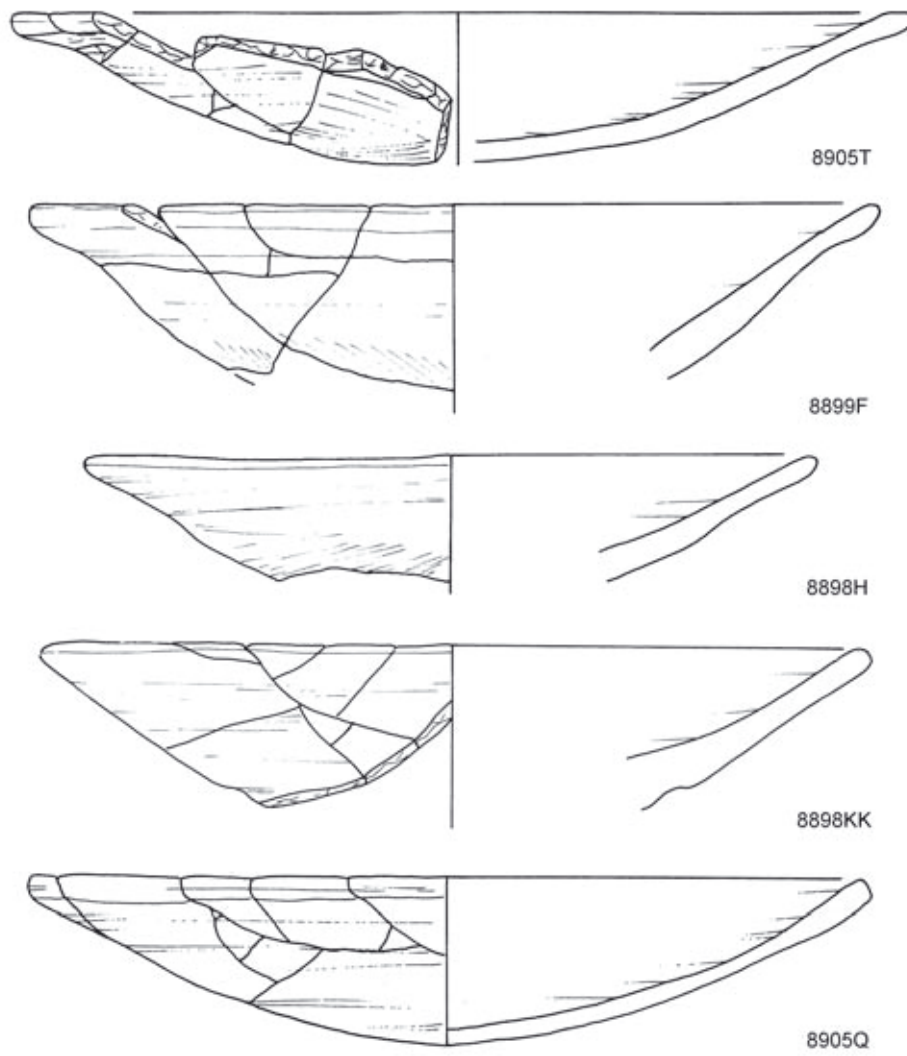

## Schalen mit geschwungener Kontur, groß, rot poliert (4)



Abb. T2

Einfache Schalen mit Standboden (5)

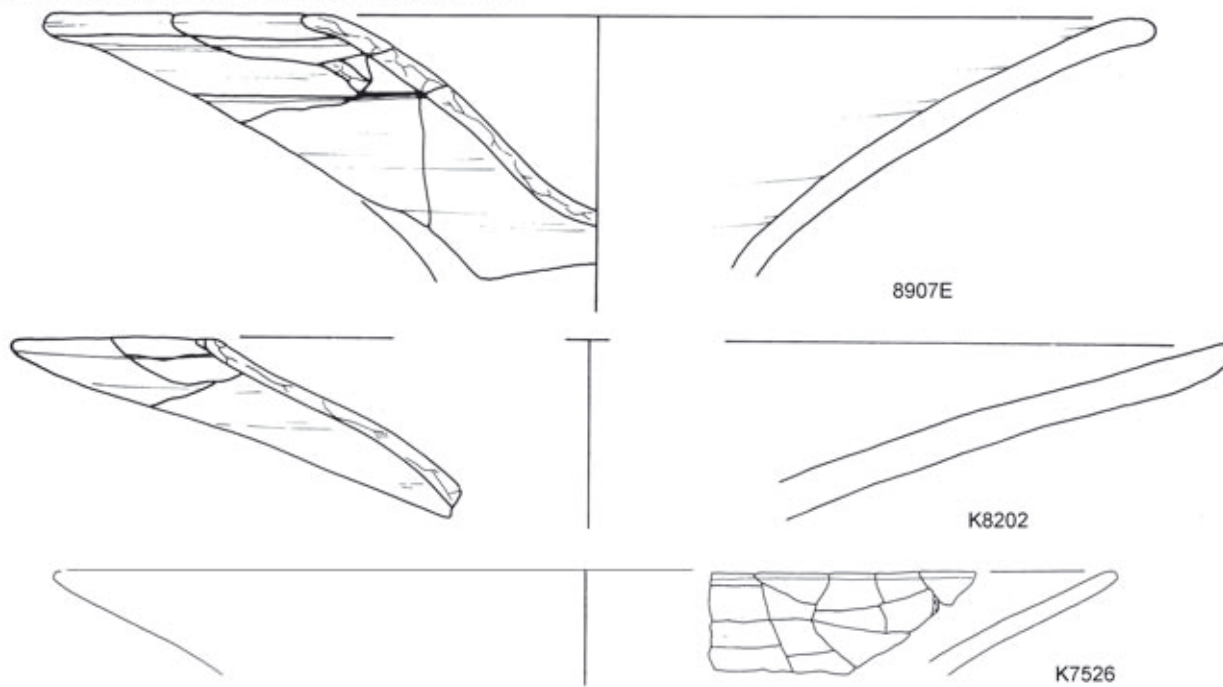

8890R

Einfache Schalen mit Außenlippe (6)



8569S

Rundbodige Schalen mit geschwungenem Rand (7)

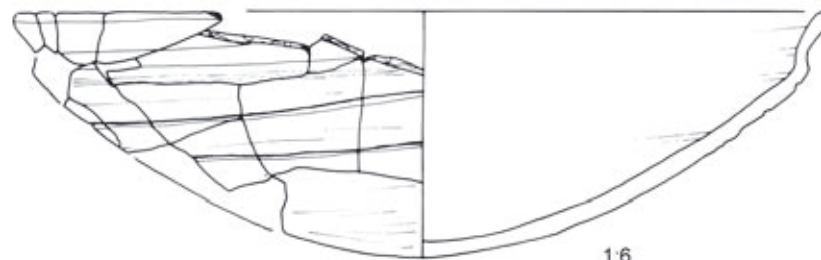

8887U

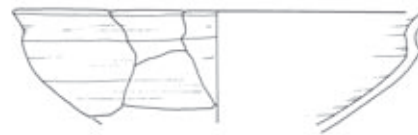

8905D

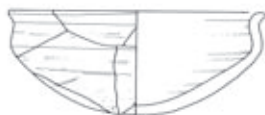

8885Y



K8111



K7600



K8386



K7580



K7354



K7423

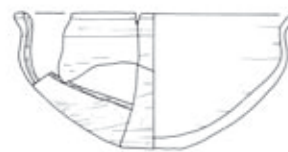

8928C

Abb. T3

Schalen mit nach innen eingeschlagenem Rand (8)



Abb. T4



a)  
U.C.18181  
Sedment, 24p  
MK Pottery HB, 339,3

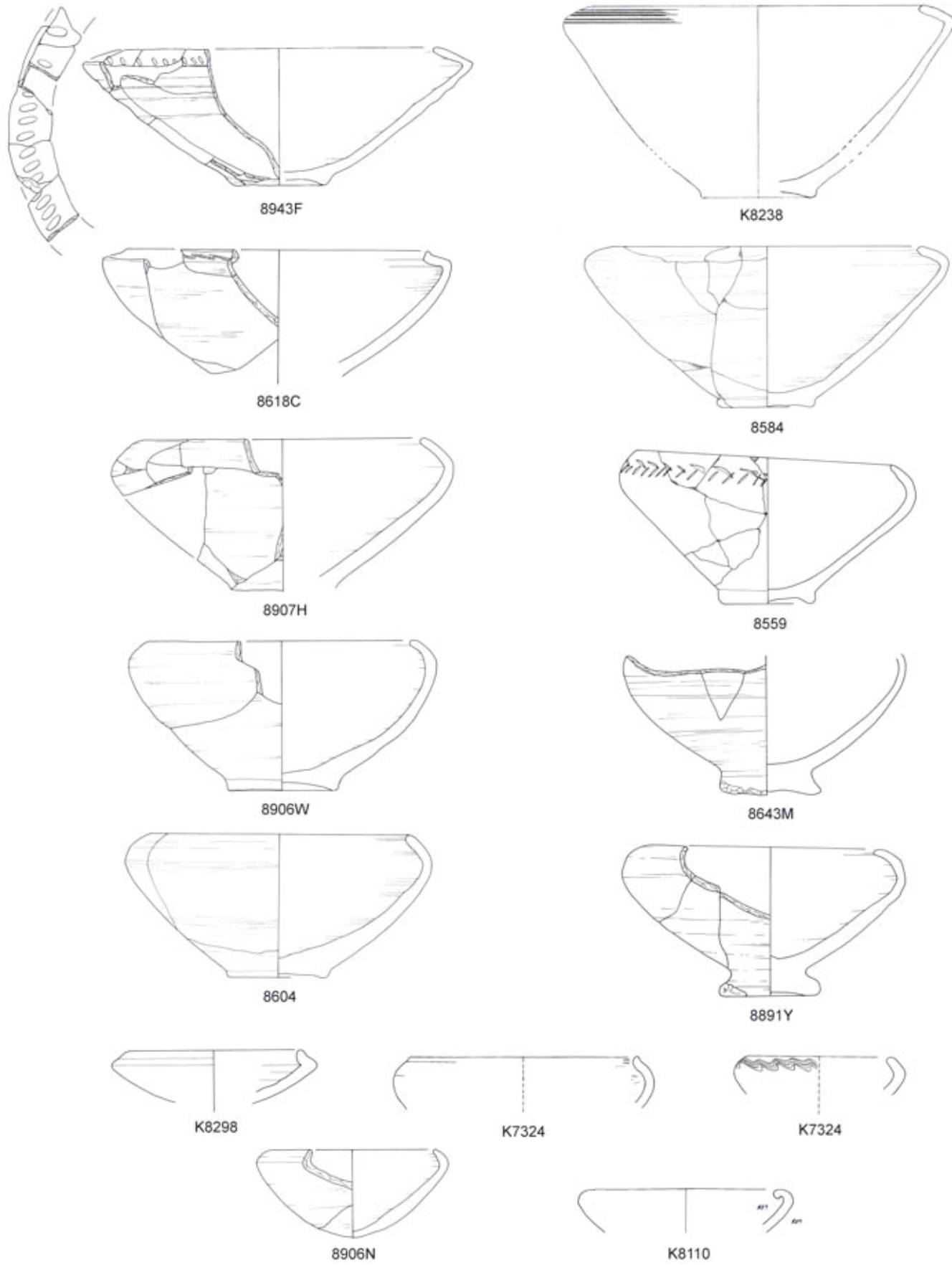
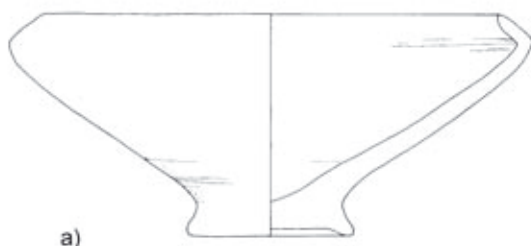
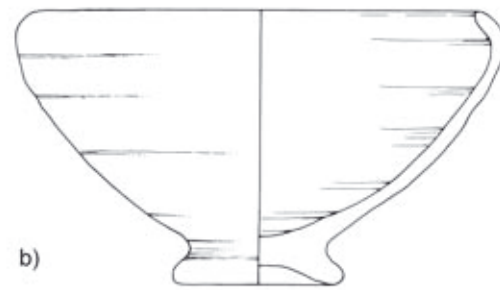

b)  
OIC 28230/MMA 21.10.27  
Sedment, 24d ?  
MK Pottery HB, 339, 1

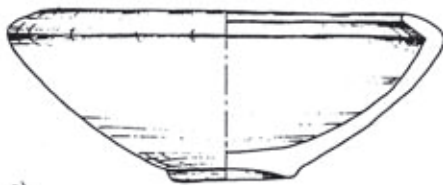

c)  
PILGRIM, *Elephantine 18*, 158r

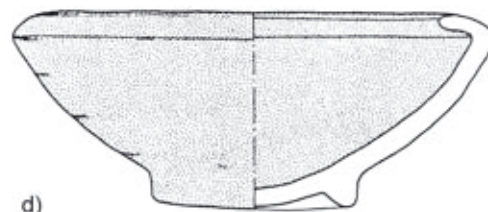

d)  
PILGRIM, *Elephantine 18*, 161f



e)

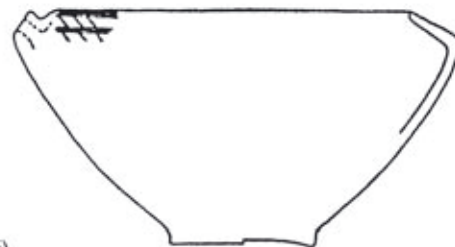

i)



f)



j)

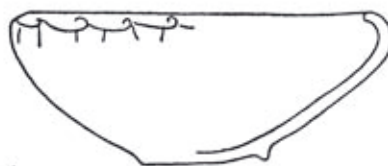

g)

e)-j) IL-Schalen aus Kahun. e) KGH 13/95=Man 362;  
f) KGH 13/45=Man 471; g) MAN 471, BURTON-BROWN,  
77, fig. 2; h) KGH 13/39; i) MAN 470, BURTON-BROWN,  
77, fig. 1; j) MAN 470, courtesy Manchester Museum,  
Photo R. Schiestl



h)



k)  
AM E2111 (EI Kab105)  
MK Pottery HB, 931,1



l)  
UC 18346 (EI Kab 58)  
MK Pottery HB, 931, 2

Abb. T5 Vergleichsstücke



Abb. T6 Näpfe Indices



Abb. T7 Näpfe Waren, Ofl.

Näpfe (9) e/4

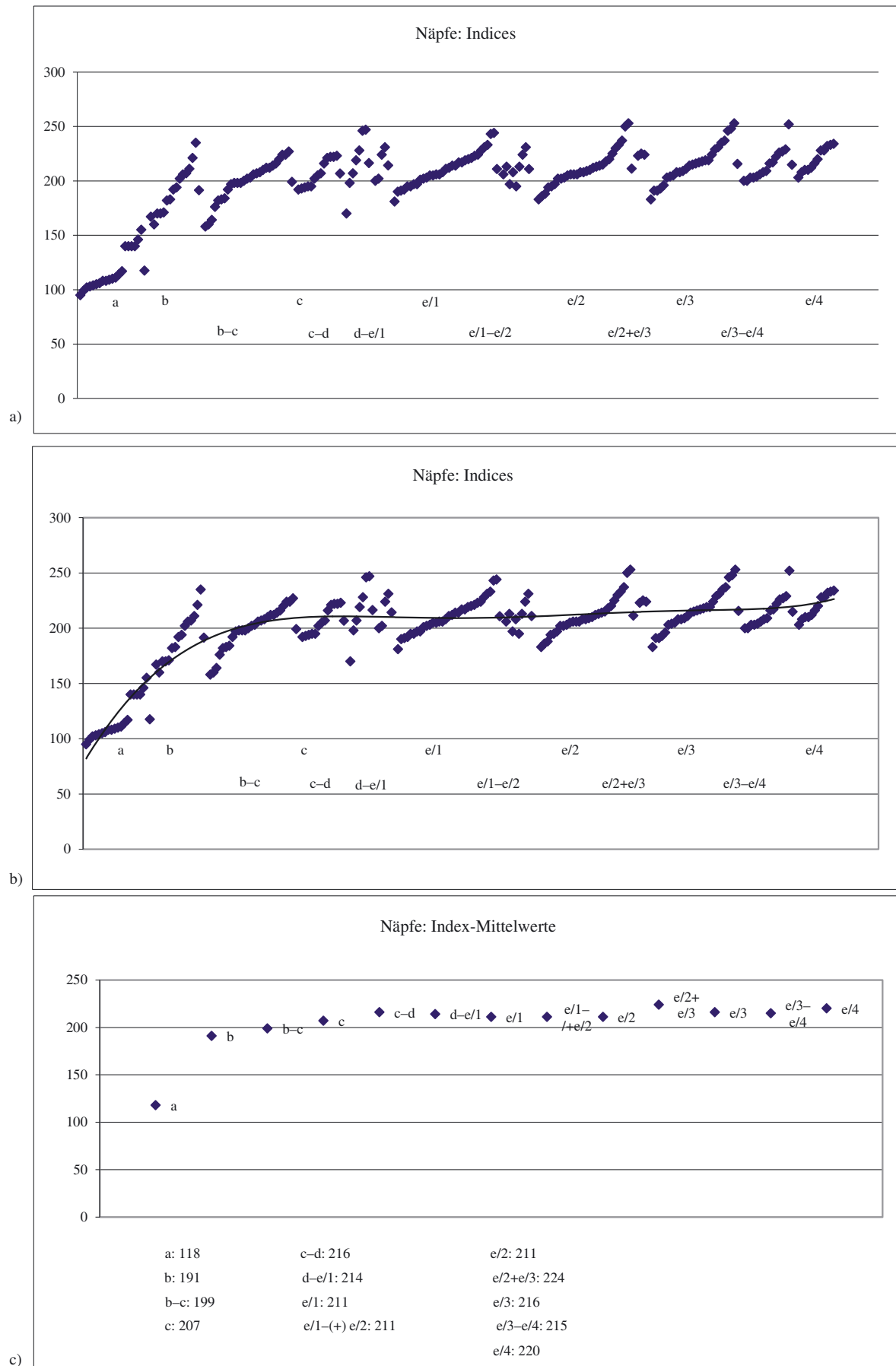

8565L

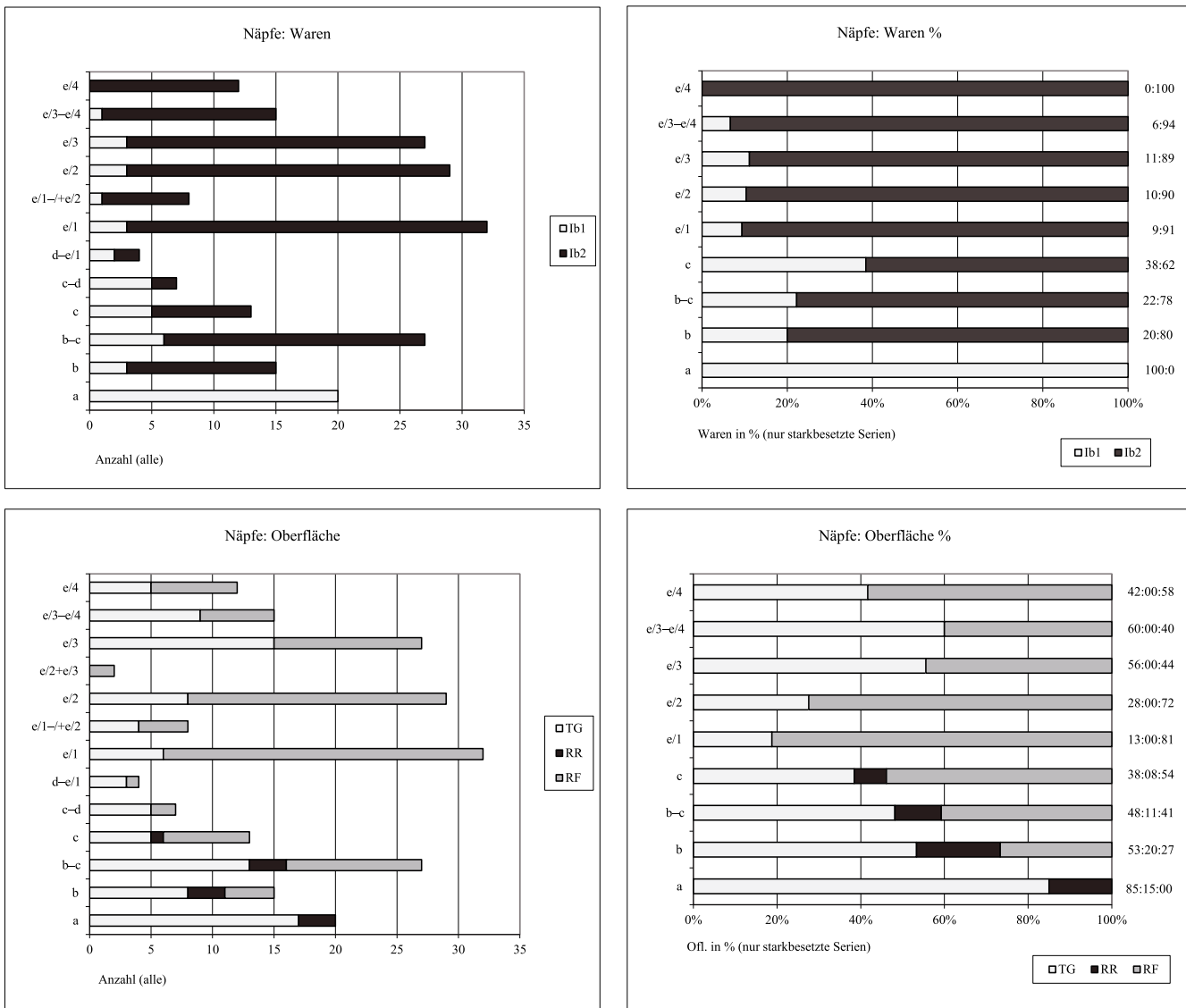
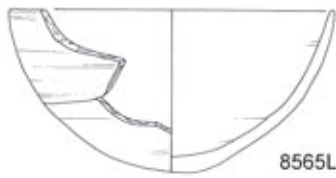
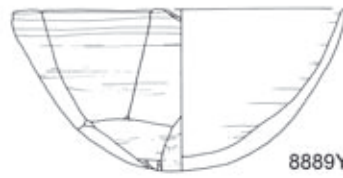

8889Y

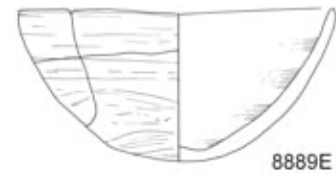

8889E

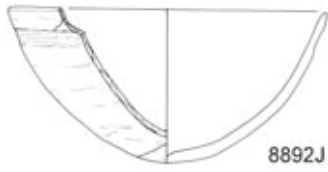

8892J

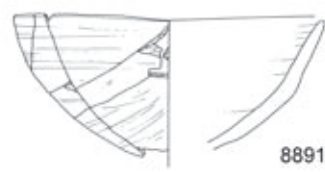

8891V

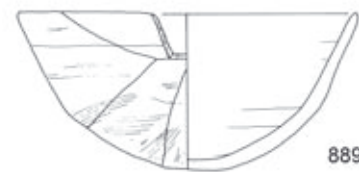

8892I

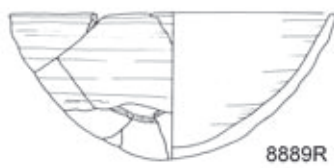

8889R

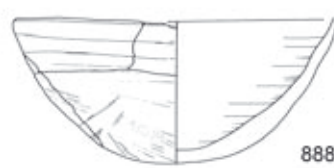

8889S

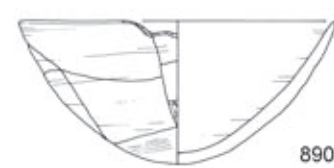

8906D

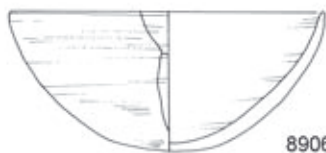

8906C



8889T



8891Z

e/3-e/4

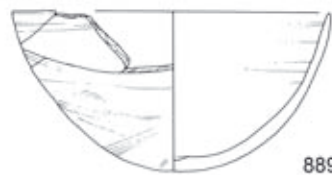

8890N

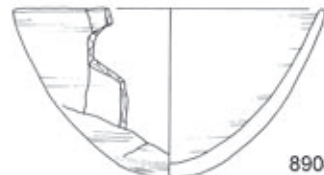

8904Q



8889D

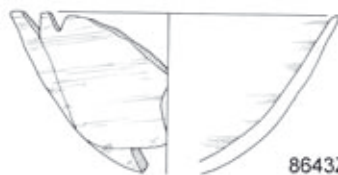

8643Z



8889M



8904P



8904O



8886N

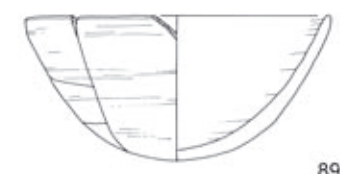

8904R

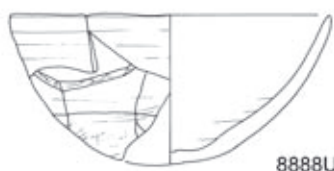

8888U



8557V



8889X

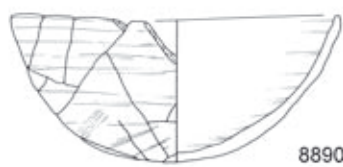

8890A

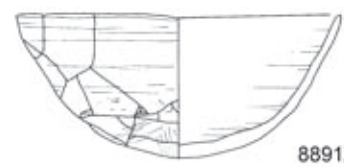

8891X



8620J

Abb. T8



Näpfe (9) e/3

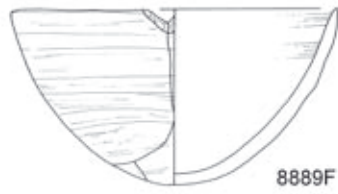

8889F



8890C

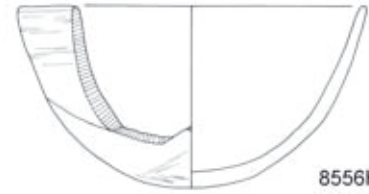

8556H

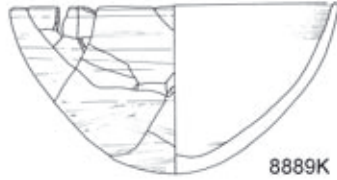

8889K

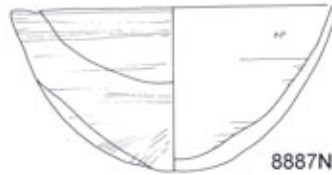

8887N

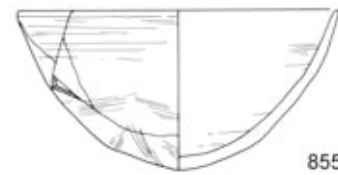

8558F

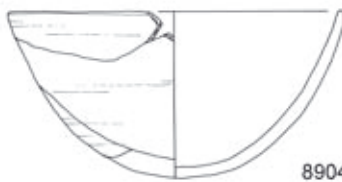

8904L



8904N



8889Z



8558G

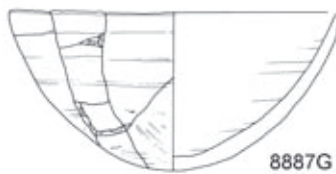

8887G

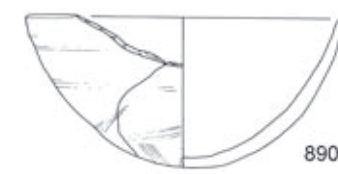

8904M

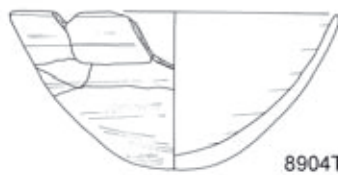

8904T



8889J

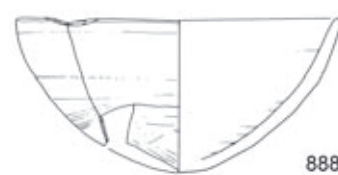

8885S



8906B



8904S



8886P

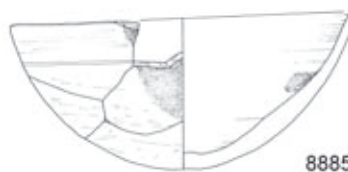

8885E

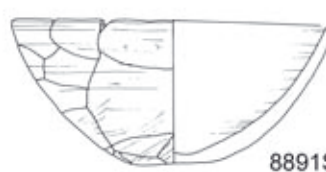

8891S



8643G

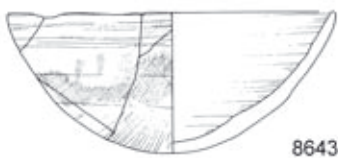

8643E

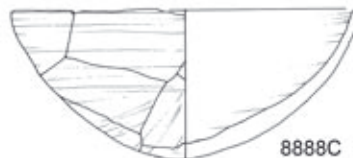

8888C



8890D

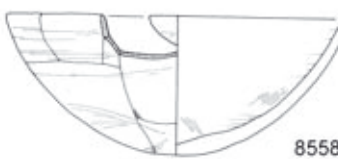

8558C

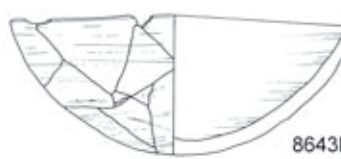

8643H

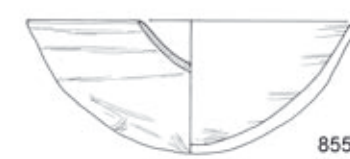

8558D

Abb. T9

Abbildungen



Abb. T10

Näpfe (9) e/1-e/2



8565H

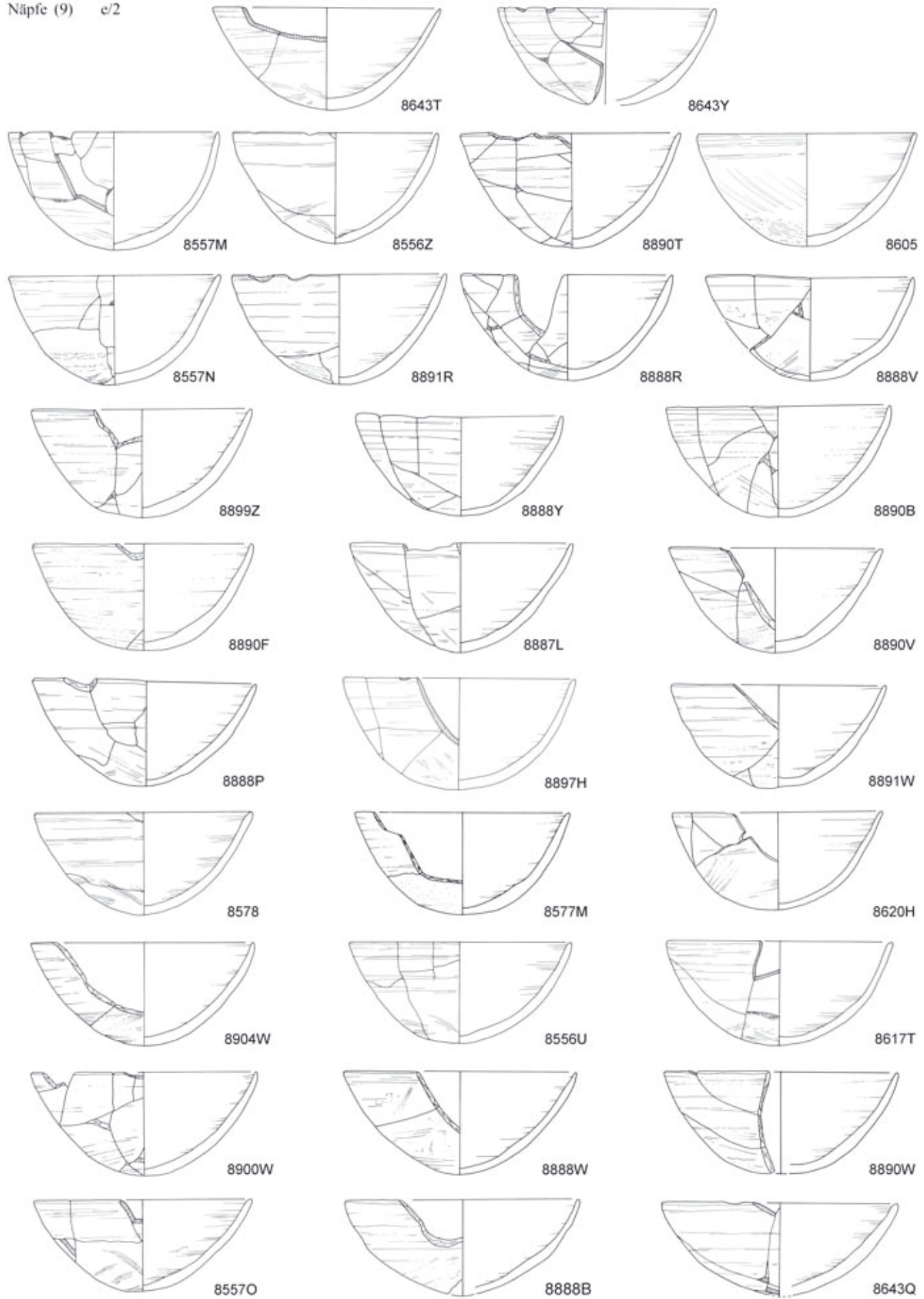
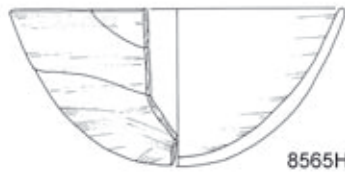
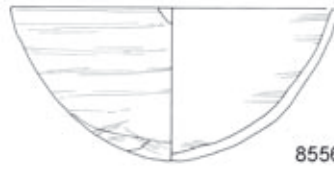

8556T

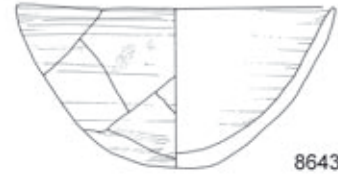

8643J

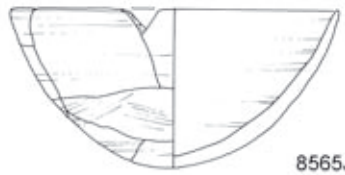

8565J

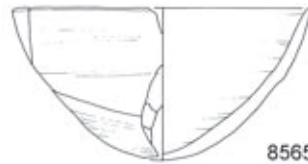

8565K



8620N



8892K

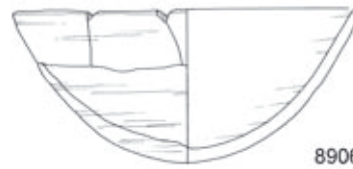

8906K

e/1

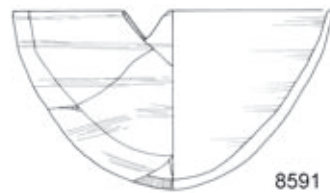

8591

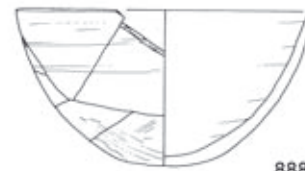

8888L

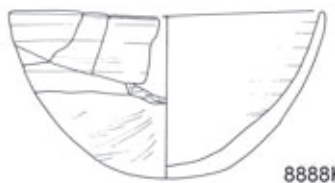

8888K

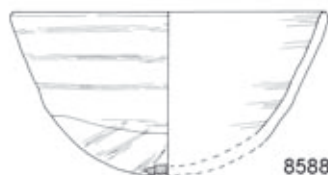

8588

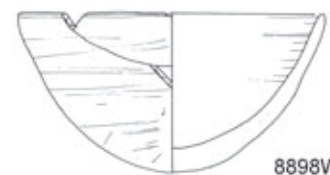

8898W



8556S

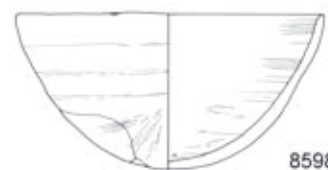

8598



8589



8556A

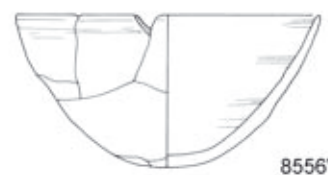

8556W

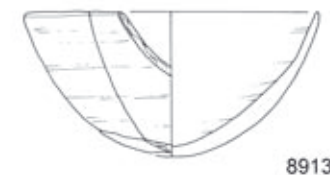

8913J

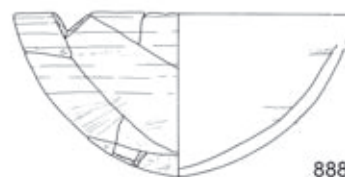

8887Z

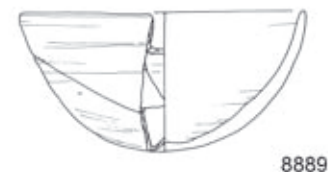

8889U



8857S

Abb. T11

Näpfe (9) e/l

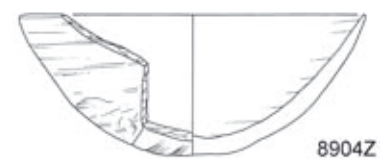
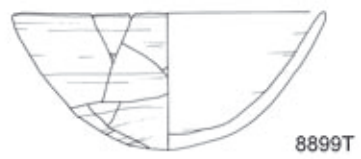
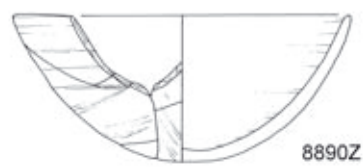
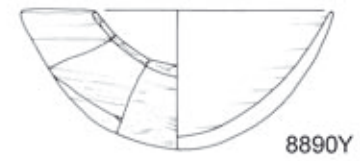
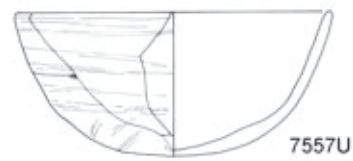
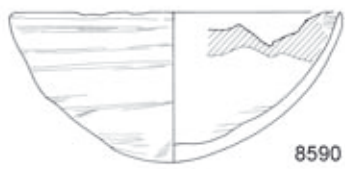
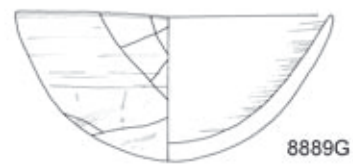
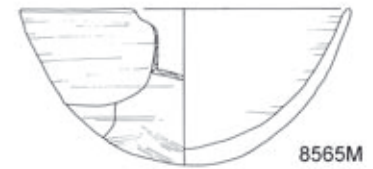
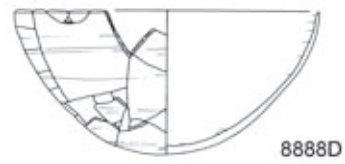
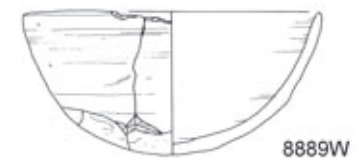

d-c/l



Abb. T12

Näpfe (9) c-d

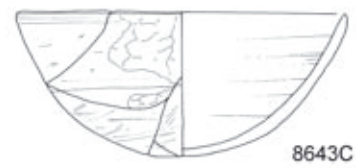
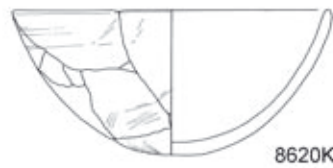
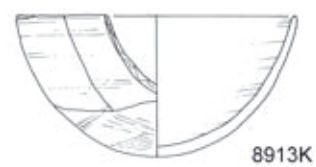
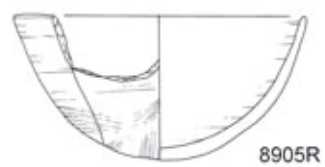

Abb. T13

Näpfe (9) b-c

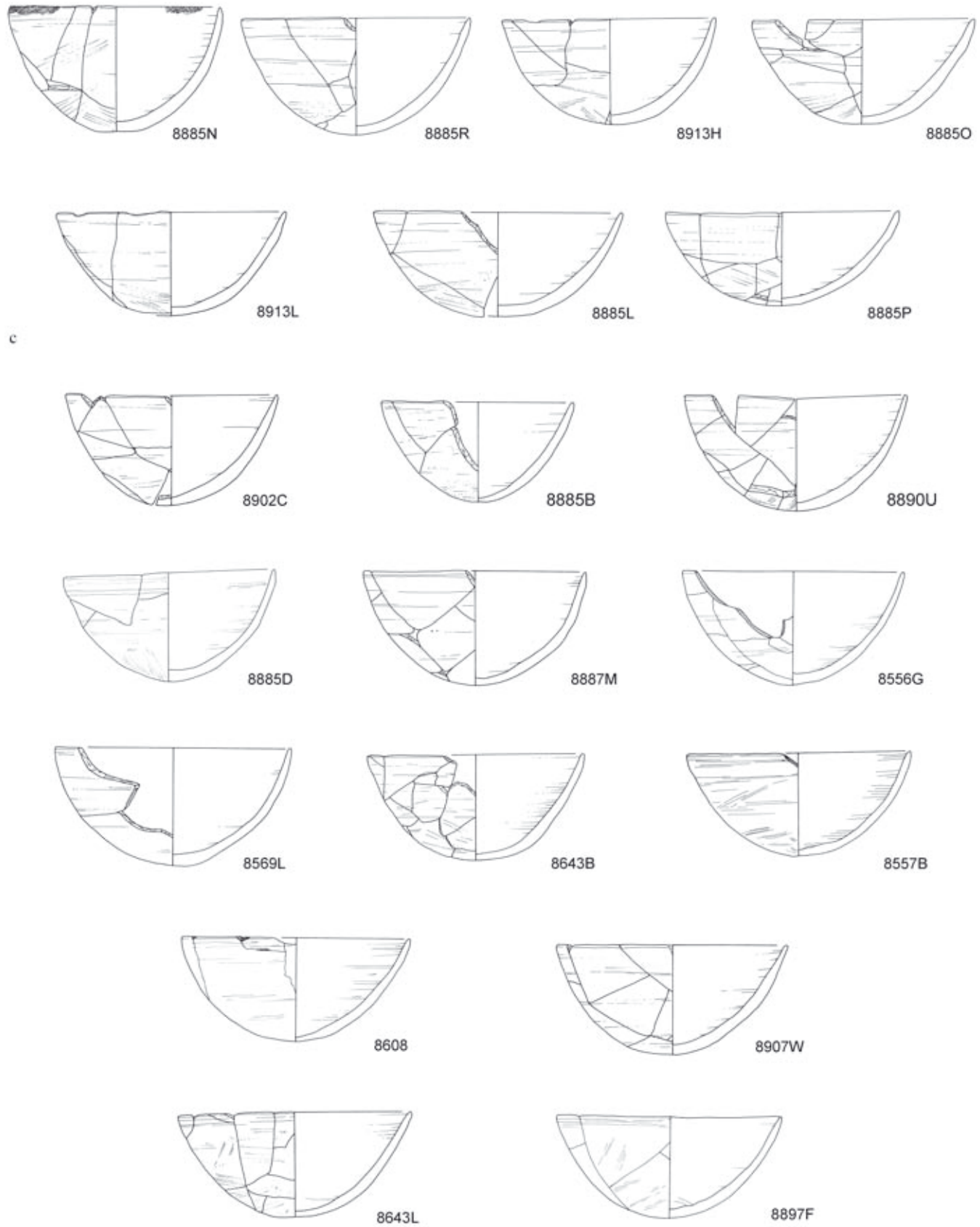

Abb. T14

Näpfe (9) b



8897G

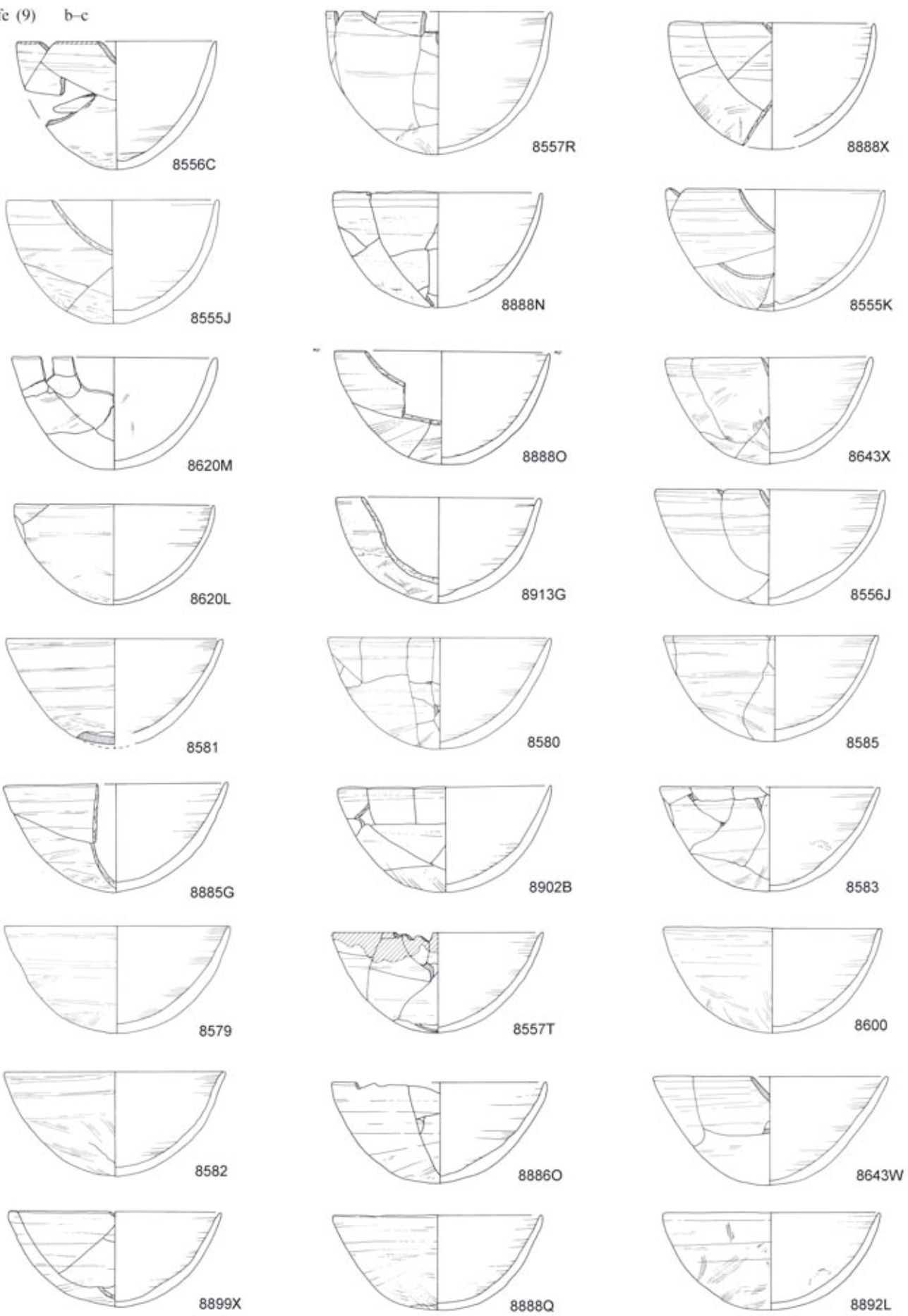
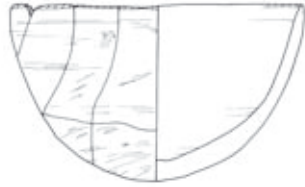

8558W



8597



8890L

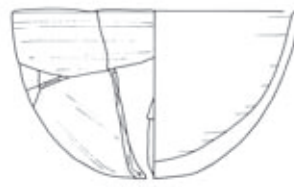

8890M



8897J

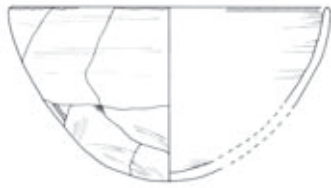

8558Z

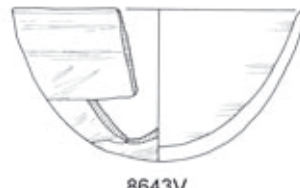

8643V



8889H



8904Y

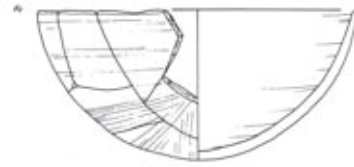

8905A



8892M

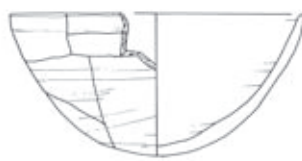

8899W

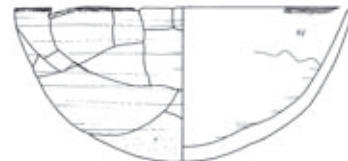

8890O



8643U

Abb. T15

Näpfe (9) a



Abb. T16



Näpfe (9)

Näpfe aus stratigraphisch nicht eindeutig festgelegten Kontexten

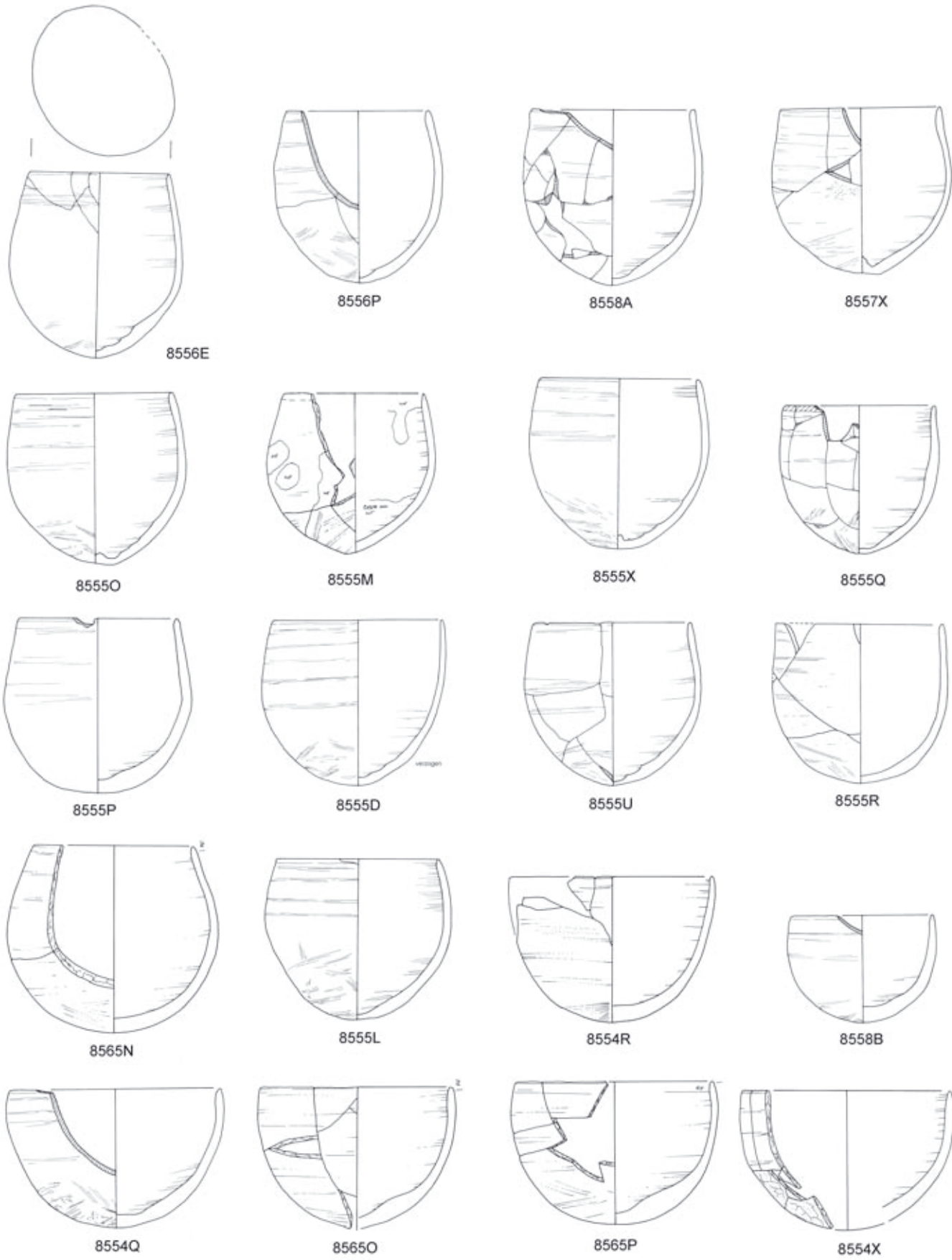

Abb. T17

## Halbkugelige tiefe Schalen mit einfachem Rand (10)



8556R

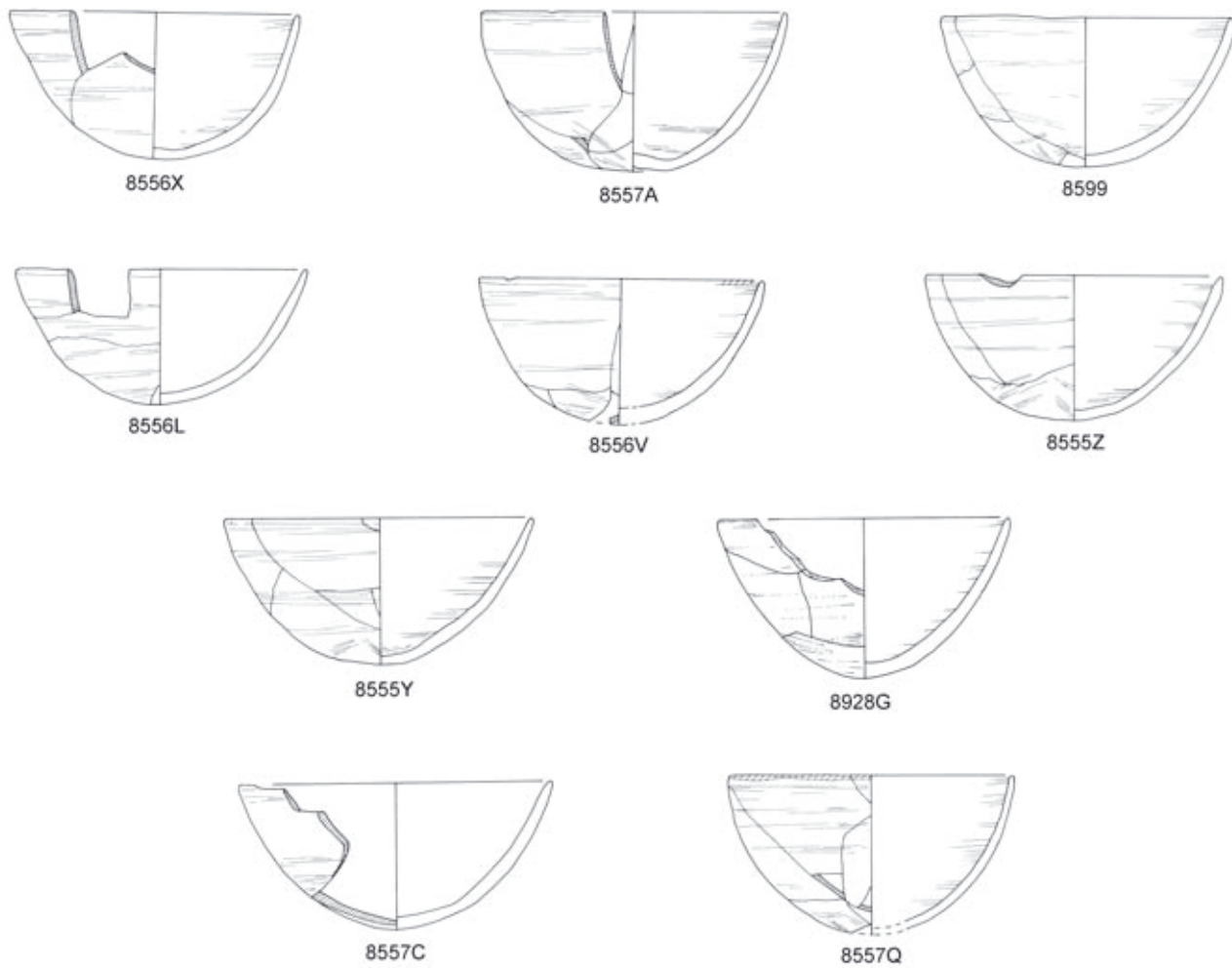
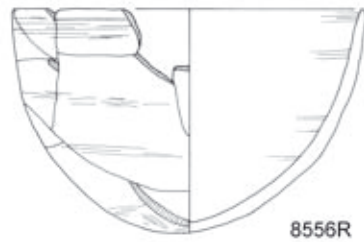
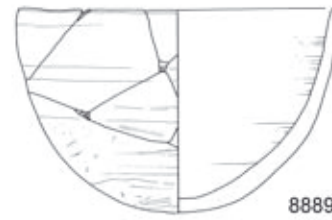

8889L

## Halbkugelige tiefe Schalen mit profiliertem Rand (11)



K7410 (+7426)

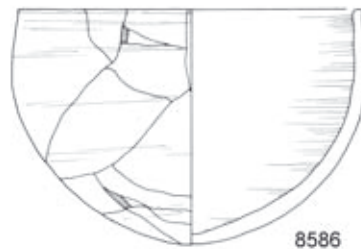

8586

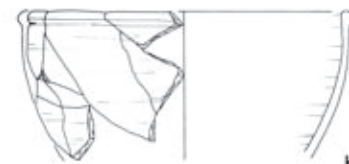

K7563

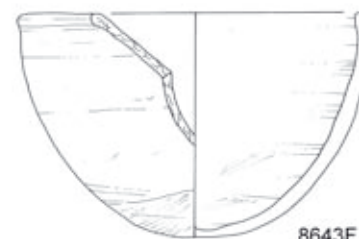

8643F

## Halbkugelige tiefe Schalen mit Rillendekoration im Randbereich, klein (12)

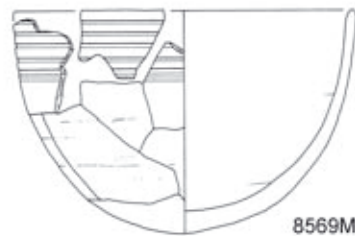

8569M

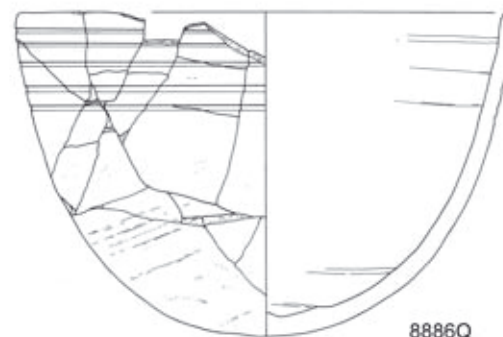

8886Q

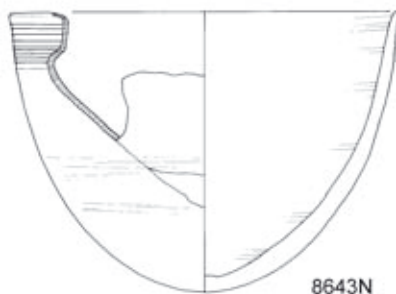

8643N

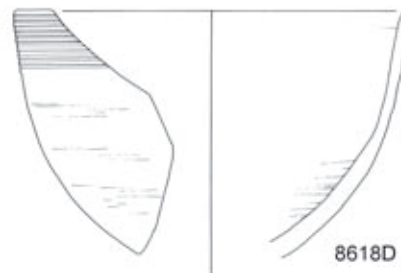

8618D

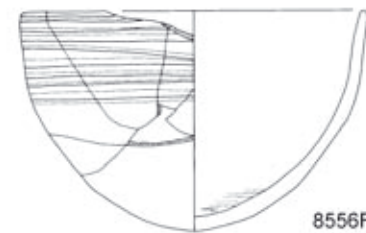

8556F

## Tiefe Becher mit rundem Boden (13)

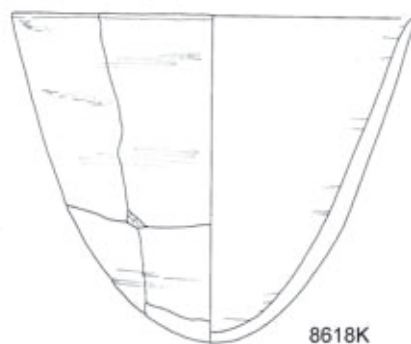

8618K

## Näpfe mit flachem Boden (14)



8556D

Knickwandschalen mit Ring-/Scheibenfuß (15)

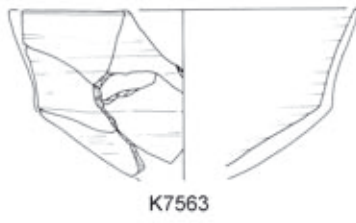
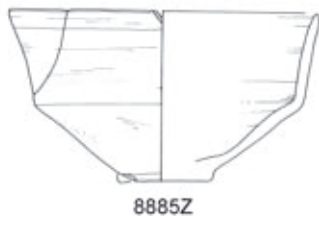
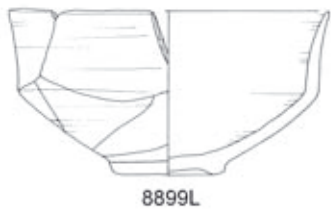
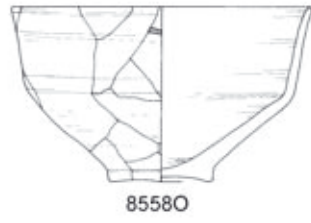

Sonderformen



Abb. T19



a) Die Bronze (Kupfer?)-Schale MM 206 aus Kahun.  
Photo: courtesy Manchester Museum; KGH, Pl. 17/7

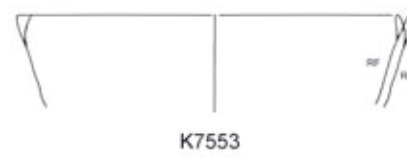

b) Schist.

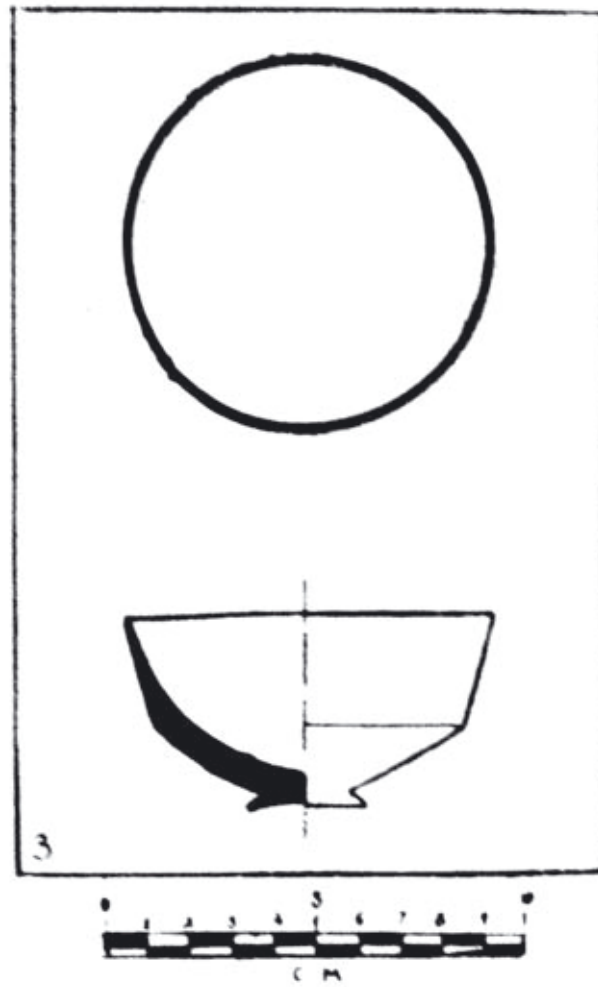

b) Die Steinschale ("Shist") aus Kom el-Hisn. ASAE 46, Pl. 62, 54.

Knickwandbecher mit Ringboden (16)

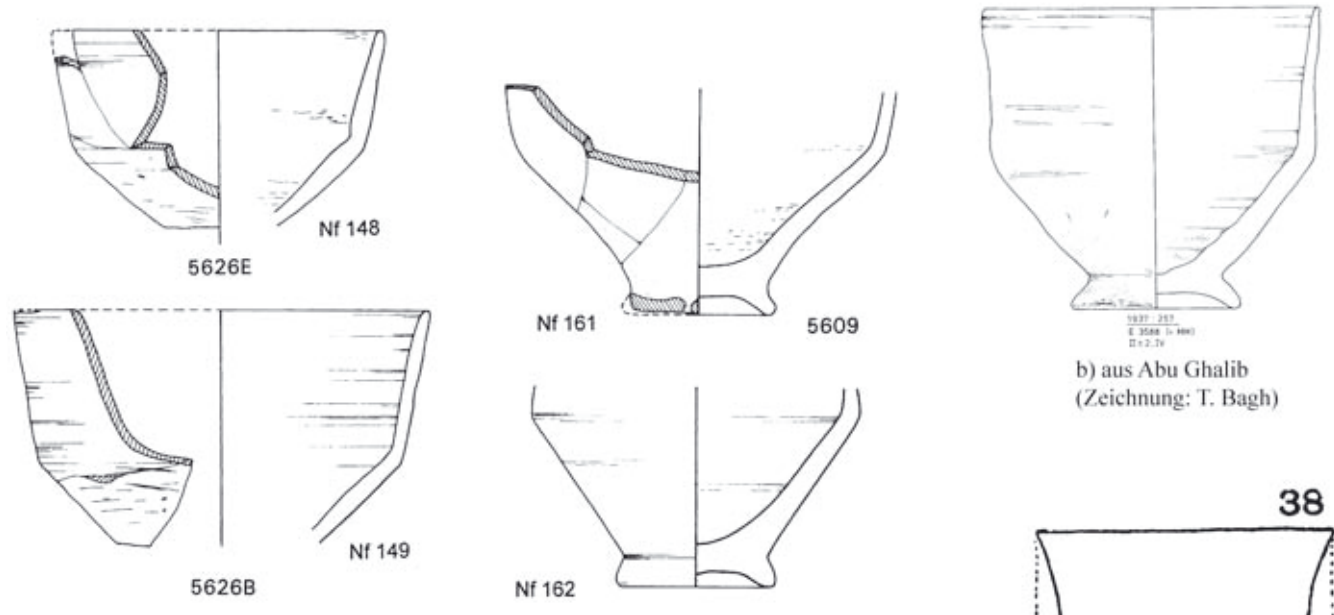
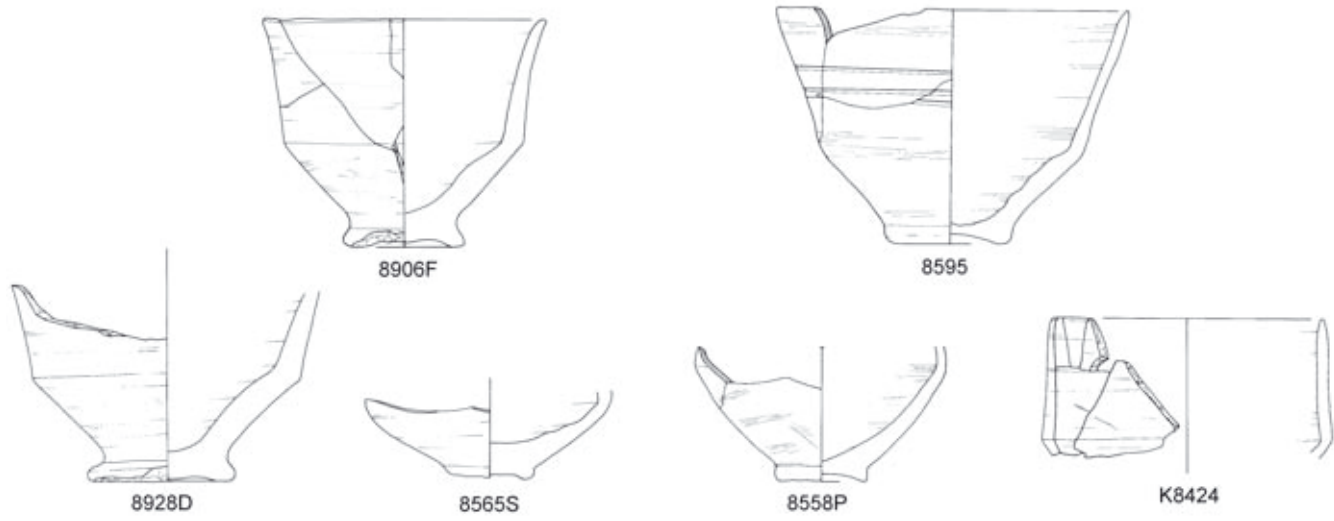

a) Vergleichsbeispiele aus TD, F/I, str. e

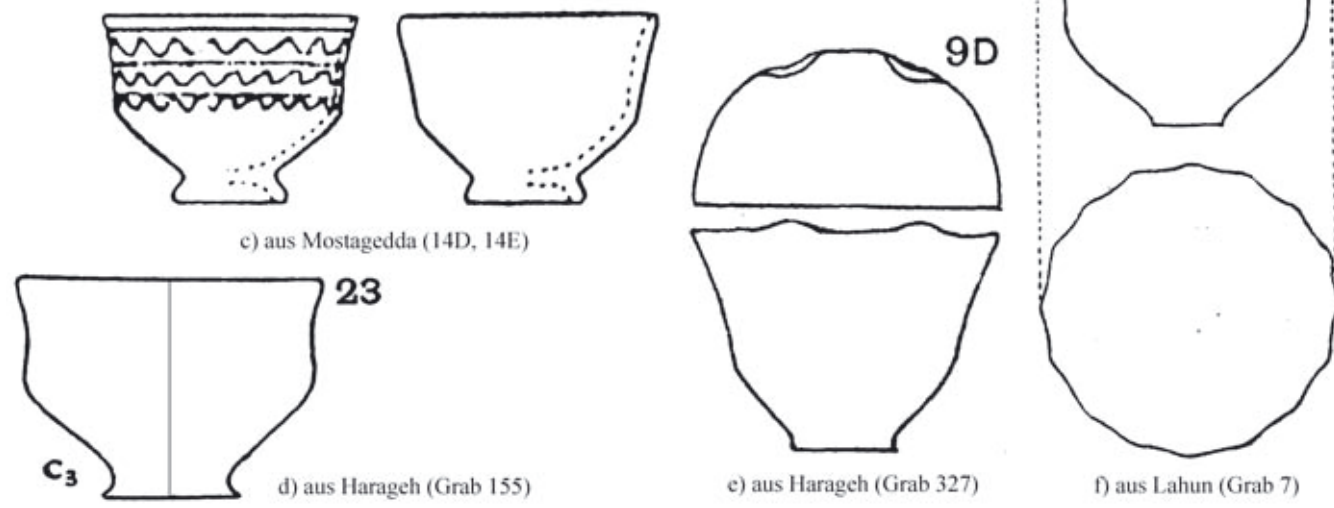

c) aus Mostagedda (14D, 14E)

d) aus Harageh (Grab 155)

e) aus Harageh (Grab 327)

f) aus Lahun (Grab 7)

Abb. T21 Vergleichsstücke

Knickwandbecher auf hohem Fuß (Kelche) (17)

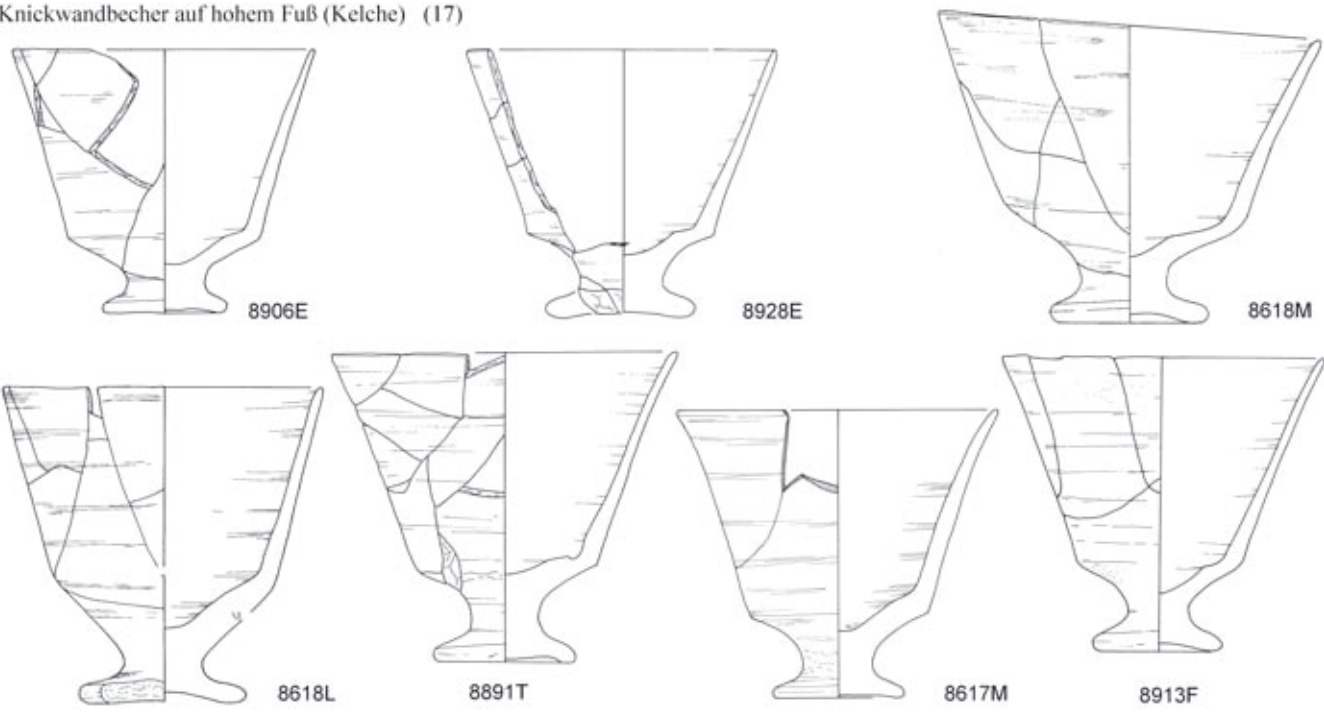

Mündungen aus dem Scherbenmaterial



Abb. T22

Kelchunterteile (Böden und Knick) aus dem Scherbenmaterial



Kelche mit Dekoration/Miniaturkelche

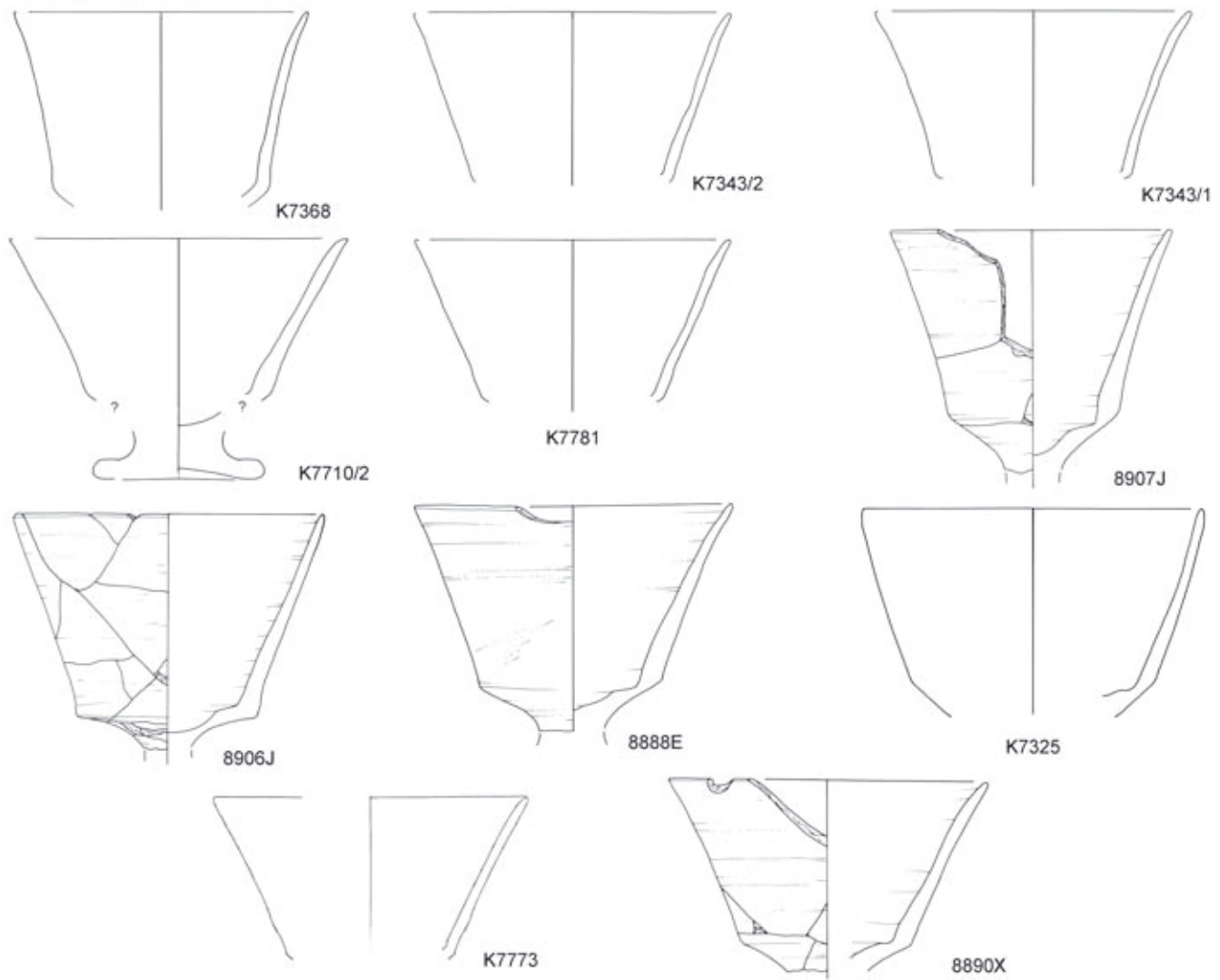

Großer Kelch mit Dekoration (?)

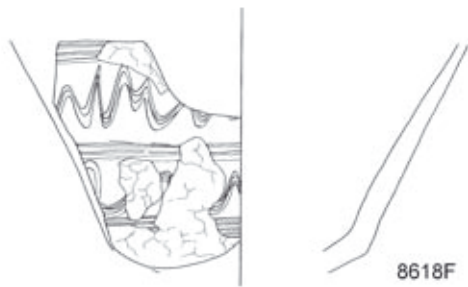

Miniaturkelch mit Ausgußtülle (?)



Abb. T23

KV/INV	str.	Radius	Hk	lk	lk2	Kelch
vollständige Kelche aus Ruschdi und Vergleichsstücke (Diagramm 1, 2, 3)						
8913F	e/1?	640	8,4	76	2,35	x
8617M	e/2	650	8,2	79	2,56	x
8891T	e/2	680	8,5	80	2,32	x
8618L	e/3	630	8,1	78	1,69	x
8618M	e/3-4	690	7,9	87	1,68	x
8928E	e/3-4	620	7,5	83	2,19	x
8906E	e/4-f	610	7,7	79	2,57	x
Anchtj3	Anchtj3	640	6,9	93	1,65	x
Anchtj2	Anchtj2	650	6,8	96	1,43	x
Anchtj1	Anchtj1	680	7	97	1,46	x
Matmar	Matmar	740	6,5	114	1,36	x
SedmentUC18182	SedmentUC	710	6,2	115	1,03	x
Abu Ghalib1	Abu Ghalib1	700	5,4	130	1,23	x
SedmentMMA	SedmentMMA	770	5,7	135	0,98	x
Abu Ghalib2	Abu Ghalib2	770	5,2	148	1,13	x
Vergleichsstücke in alten Zeichnungen oder Photos (Diagramm 4)						
Tell Basta	Tell Basta	?	?	80	2,36	x ca.
Rifeh3	Rifeh3	680	7,6	89	ca. 1,58	x
Qau10A	Qau10A	720	7,8	92	1,95	x
SedmentCA	SedmentCA	700	7	100	1,4	x
Rifeh13	Rifeh13	650	6,2	105	1,23	x
Dahshur	Dahshur	630	6	105	1,11	x
Gurob6	Gurob6	590	5,1	116	1,06	x
Harageh23	Harageh23	810	7	116	1,11	x
Mostagedda	Mostagedda	700	5,8	121	1,29	x
Ma4331A-Rifeh	Ma-Rifeh	735	5,8	127	1,04	x
Rifeh19	Rifeh19	590	3,2	184	0,66	x
ausgewählte Kelchfragmente aus Ruschdi: Mündungen						
8890X	e/1	710	7,4	96	2,18	x erg.
K7325	e/1	750	7,7	97		x
K7773	e/1	700	7	100		x
8888E	e/1?	710	8,1	88	1,93	x erg.
8906J	e/1-2	690	9	77	2,37	x erg.
8907J	e/2	620	8,2	76	1,78	x erg.
K7781	e/2	700	7,1	99		x
K7710	e/3	750	6,85	109	ca. 1,75?	x
K7343	e/3-4	700	7,3	96		x
K7343	e/3-4	700	7,4	95		x
K7368	e/4-f	650	7,8	83		x

Abb. T24 Kelche: Überblick



KV/INV	str.	Radius	Hk	lk	lk2	Kelch
ausgewählte Kelchfragmente aus Ruschdi: Böden						
8887O	e/1	610+x	6,10+x	?	1,77+x	x
8885X	e/2-3	745 (+x?)	8,1 (+x?)	92 (?)	2,07 (+x?)	x erg.
8886W	e/2-4	670+x	7,85	85+x	2,06+x (2,30?)	x erg.
8643P	c, gestört	580+x	5,4+x			x
8928B	c-d?	560+x	6,1	92-x	1,37+x	x
8617U	e/2	560+x	5,6+x	100-x	1,4+x	x
8885W	e/2-3	460+x	3,7+x			x
8890P	e/3	560+x	5,2+x			x
8888A	e/3-4	540+x	4,8+x			x
8890J	e/3-4	530+x	4,8+x			x
8890K	e/3-4	530+x	5+x			x
8906H	e/4-f	560+x	4,1			x
Vergleichsstücke in alten Zeichnungen oder Photos 2 (Diagramm 5)						
Tell Basta	Tell Basta	?	?	80	2,36	x ca.
Qau10A	Qau10A	720	7,8	92	1,95	x
Rifeh3	Rifeh3	680	7,6	89	1,58	x ca.
SedmentCA	SedmentCA	700	7	100	1,4	x
Rifeh8	Rifeh8	490	4,6	107	1,34	x
Rifeh13	Rifeh13	650	6,2	105	1,23	x
Dahshur	Dahshur	630	6	105	1,11	x
Gurob6	Gurob6	590	5,1	116	1,06	x
Ma4331A-Rifeh	Ma-Rifeh	735	5,8	127	1,04	x
Rifeh19	Rifeh19	590	3,2	184	0,66	x
Dekorierte Kelche						
8906M	e/3-4	490	5,8	84		x
8906G	e/3-4	?	?	?	1,62+x	x
Denderah SL C8f	Denderah C8f					x
Mostagedda	Mostagedda					
Miniatur						
K7710	e/3	580	6	97		x Miniatur
K8239	e/3	355+x	2,5+x			x Miniatur
Rifeh8	Rifeh8	490	4,6	107	1,34	x Miniatur

Abb. T25 Kelche: Überblick



Abb. T26 Kelche: Diagramm 1-3



Abb. T27 Kelche: Vergleiche, Diagramm 4-5

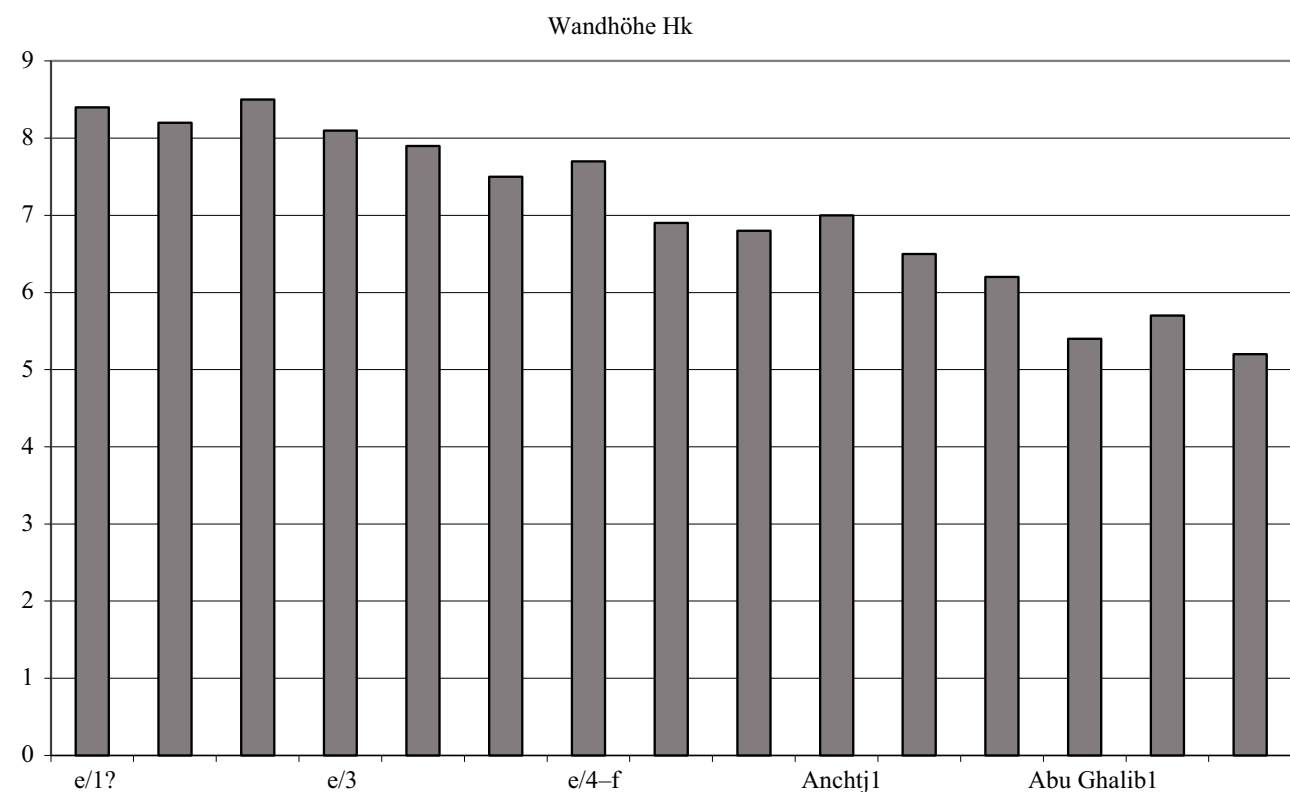
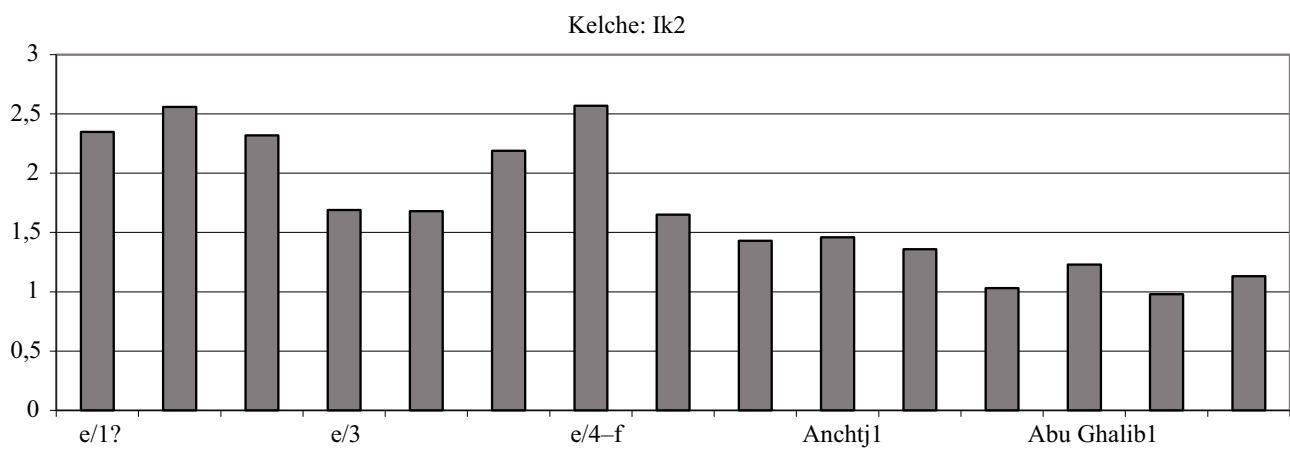
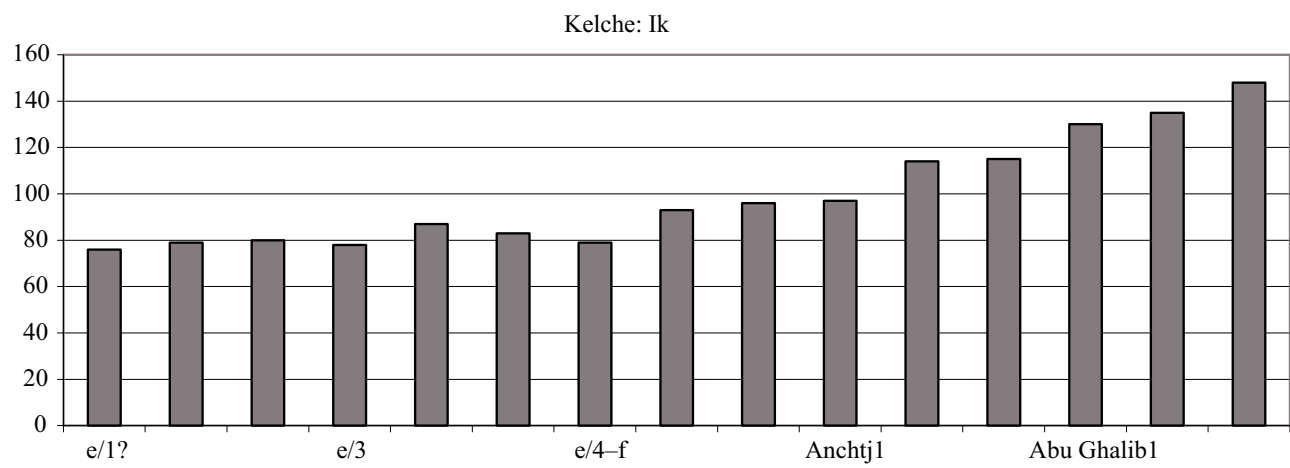

a) „Wassergefäß und Kelch“ in Grab 491 in Matmar

b) Keramik aus dem Grab der Anchtj (Do. ARNOLD, *The Pyramid Complex of Senwosret I*, Pl. 69)

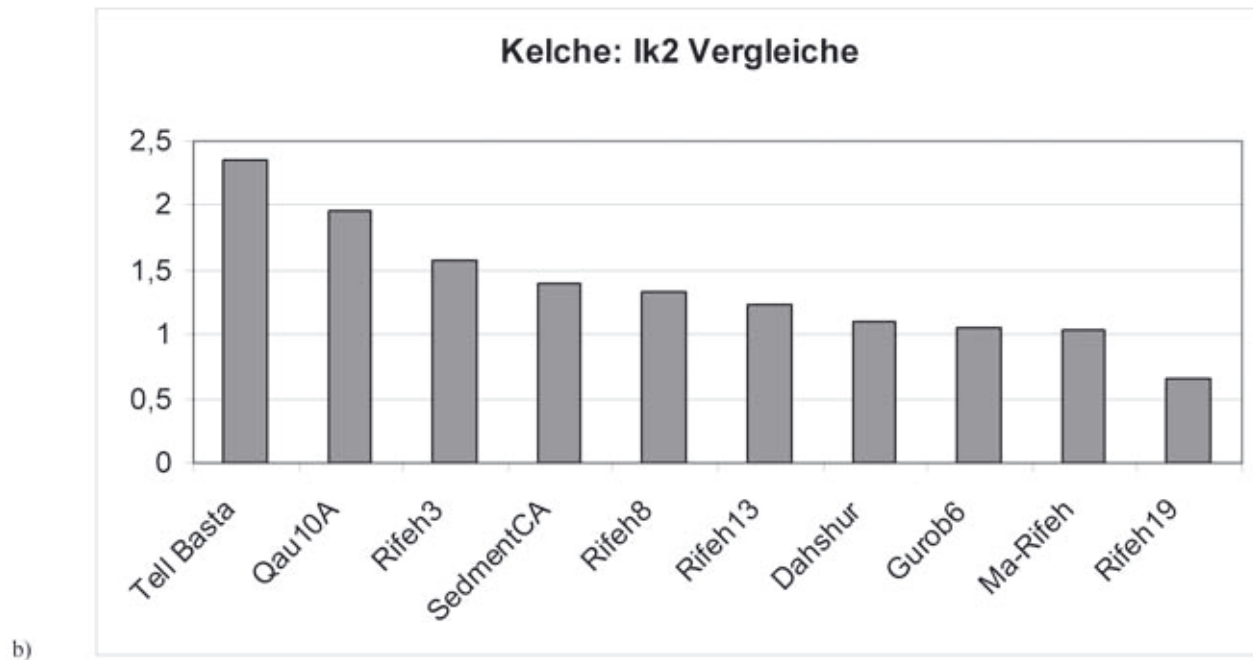
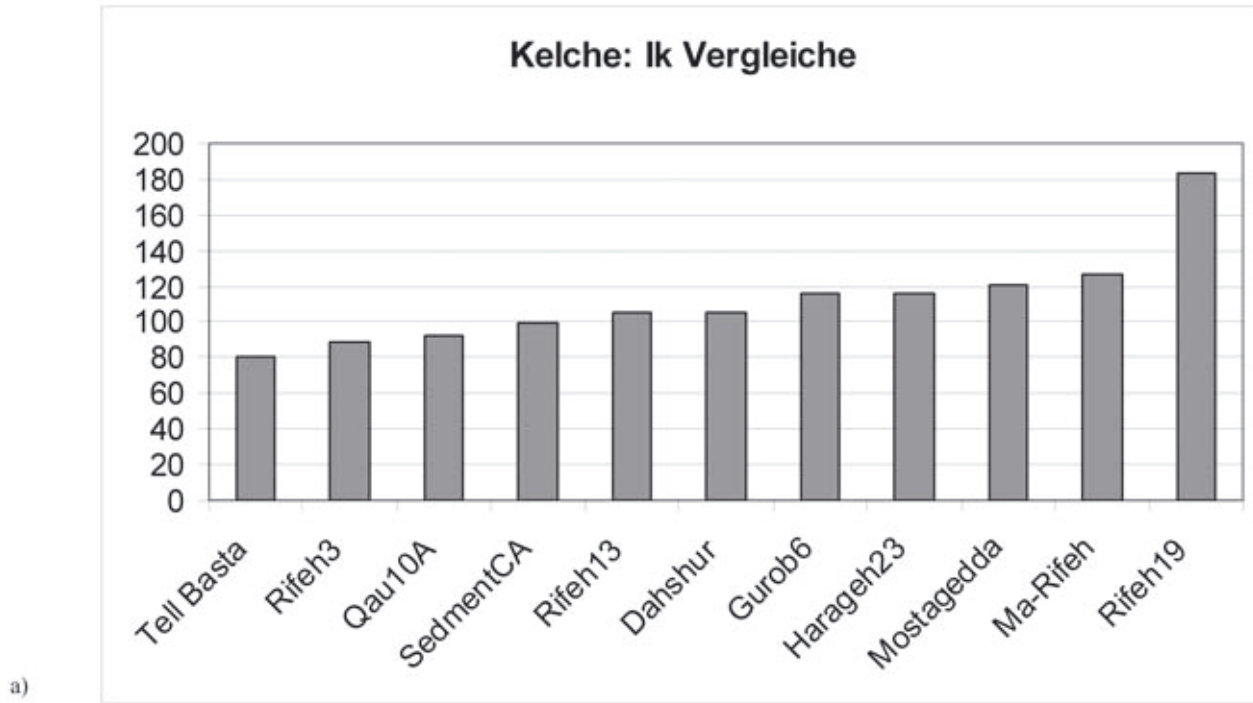
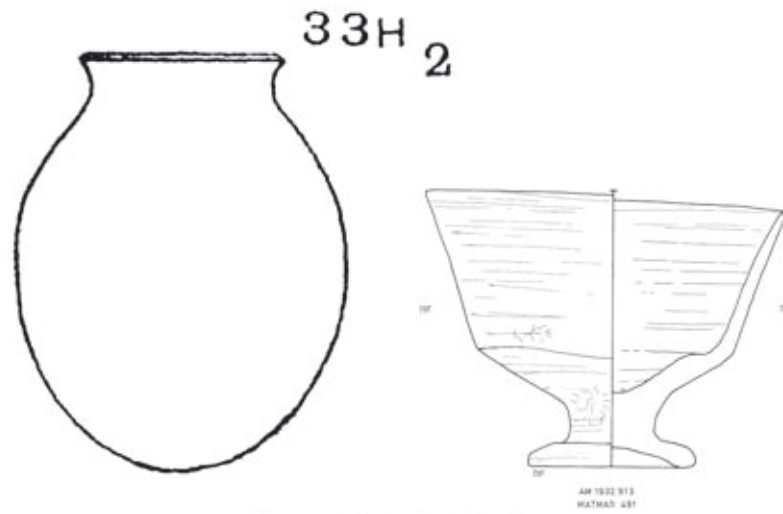
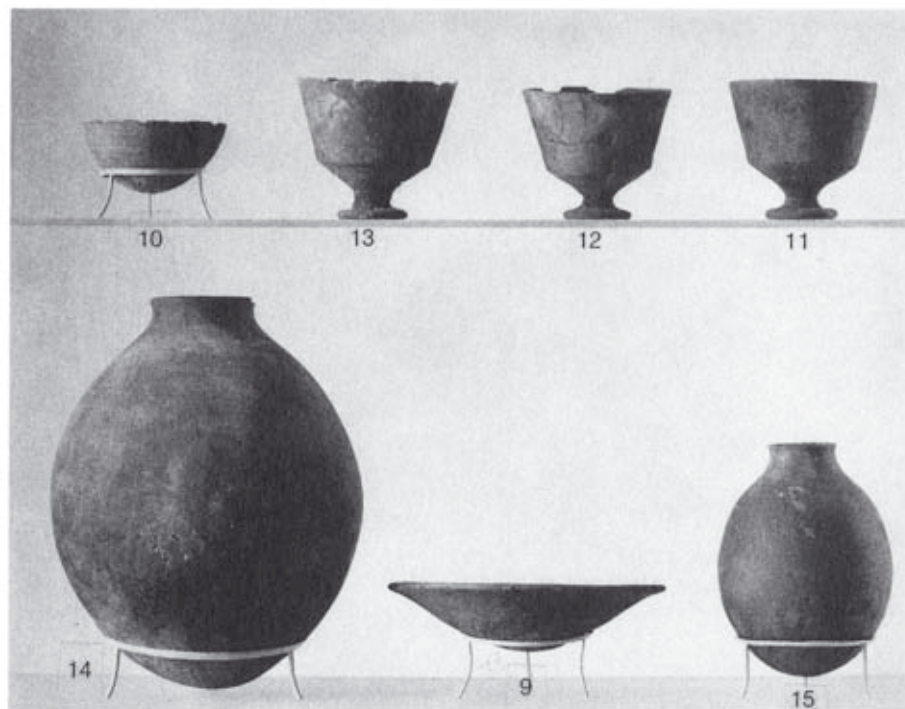
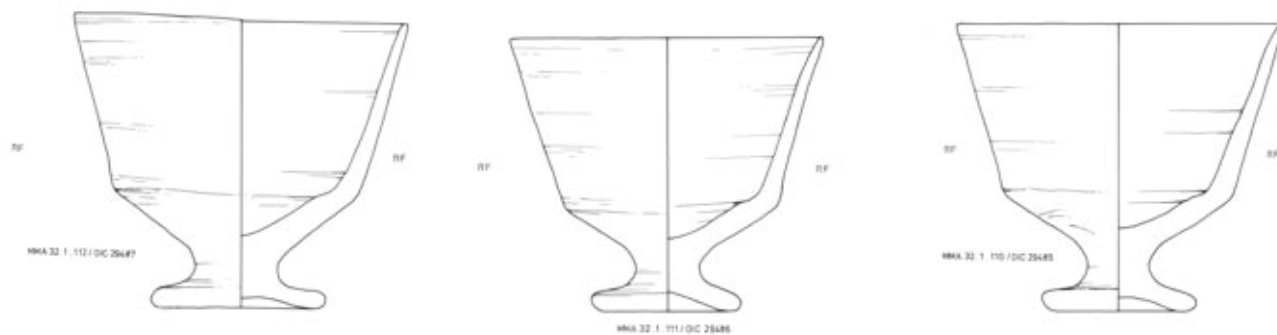
c) Kelche aus dem Grab der Anchtj in Lischt-S (courtesy Do. Arnold, MMA, NY)

Abb. T28 Kelche: Vergleichsstücke

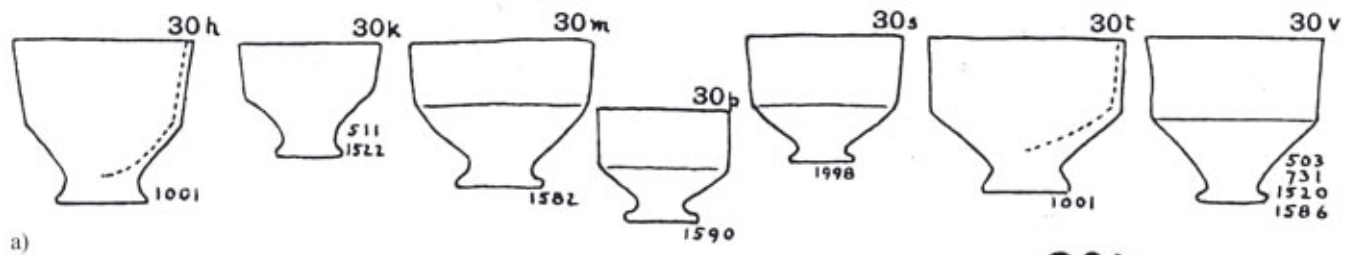

a)

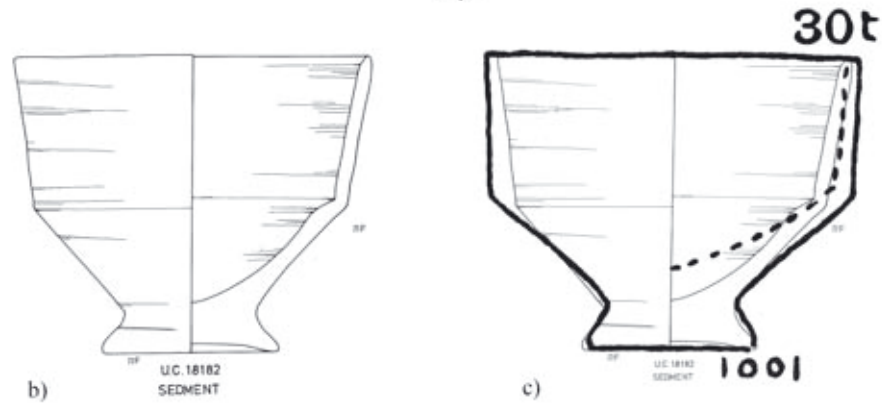

b)

c)



d) 30m; Grab 1582

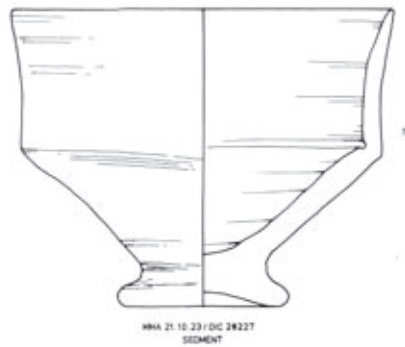

e) 30v ?

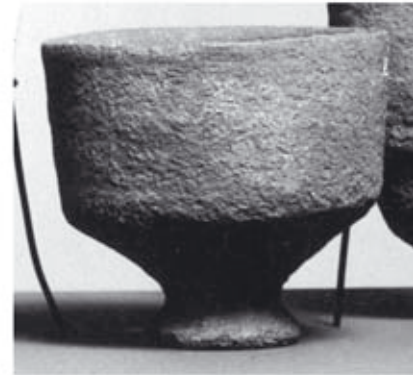

f) 30s ?

„Kelche“ aus Sedment: a) PETRIE, *Sedment*, Pl. 30/2; b) UC 18182, aus Grab 1001, Typ 30t;  
 c) Typ 30t skaliert über UC 18182 geblendet; d) UC 188182, aus Grab 1582, Typ 30m;  
 e) MMA 21.10.23/OIC 28227 (courtesy D. Arnold, MMA), Typ 30v ?; f) Ny Carlsberg AEIN1579, Typ 30s ?

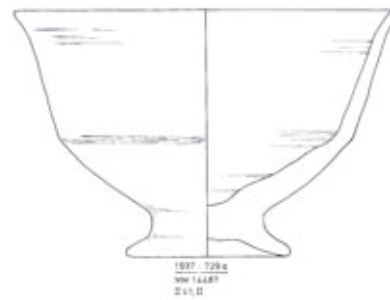

g) 2 „Kelche“ aus Abu Ghalib (T. BAGH, *MDAIK* 58, 49, 4k; Medelhavsmuseet, Stockholm, courtesy T. Bagh)

Abb. T29 Kelche: Vergleichsstücke



a) „Kelch“ aus Tell Basta,  
M. BAKR, *L'Égyptologie en 1978*, Fig. 16.

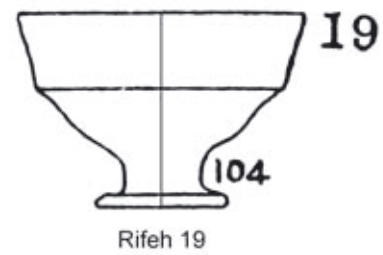
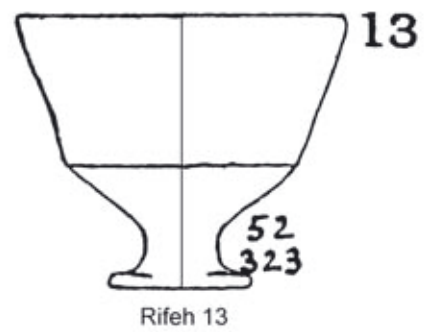
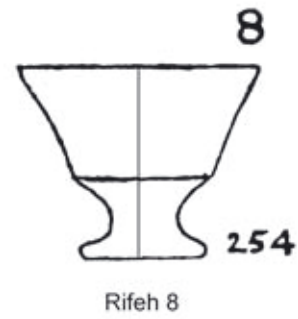
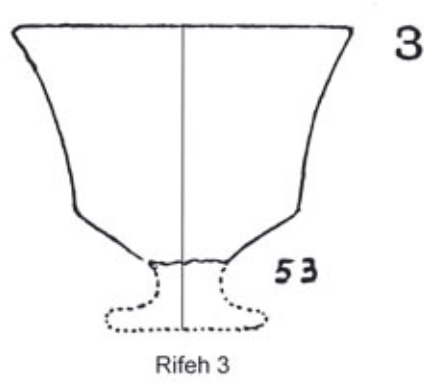

b) „Kelche“ aus Rifeh, PETRIE, *Gizeh and Rifeh*, Taf. 13A

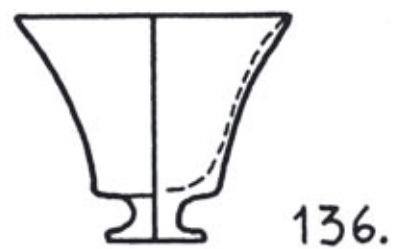

c) 2 „Kelche“ aus Buhen. EMERY/SMITH/MILLARD,  
*Fortress of Buhen*, Pl. 67/135/136

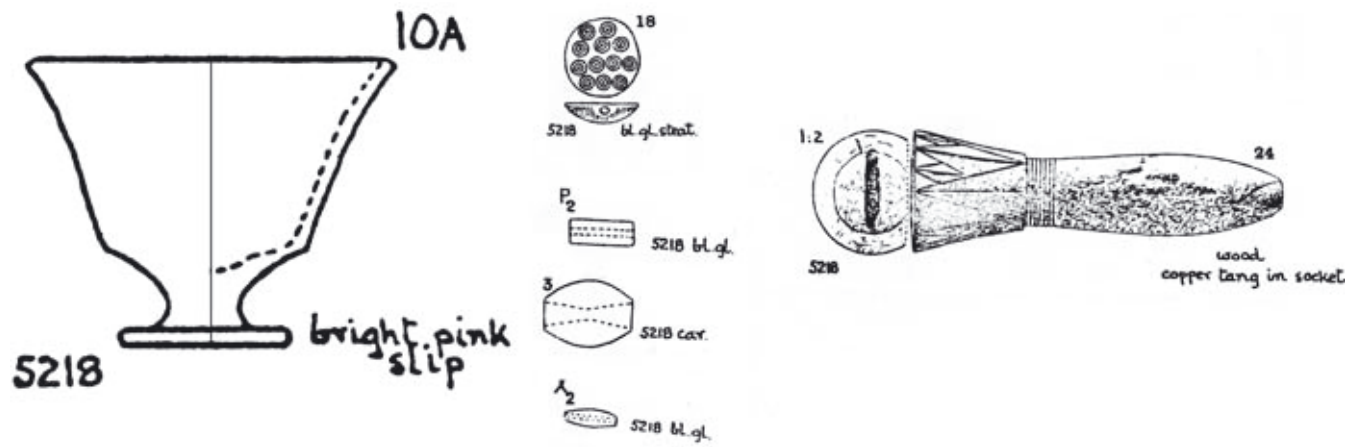

a) Der „Kelch“ aus dem Grab Badari 5218 mit seinem Fundkontext.  
Nach G. BRUNTON, *Qau and Badari III*



b) Ausschnitt aus der Stele BM 559,  
ANOC 43.1 (KELLY-SIMPSON, *Terrace of the Great God*, Pl. 62)



c) Kom Barnugi, C.C. EDGAR in MASPÉRO,  
*Le musée égyptien* 2, 115



d) Beni Hassan, Grab des Amenemhet,  
NEWBERRY, *Beni Hassan I*, pl. II

Abb. T31 Kelche: Vergleichsstücke

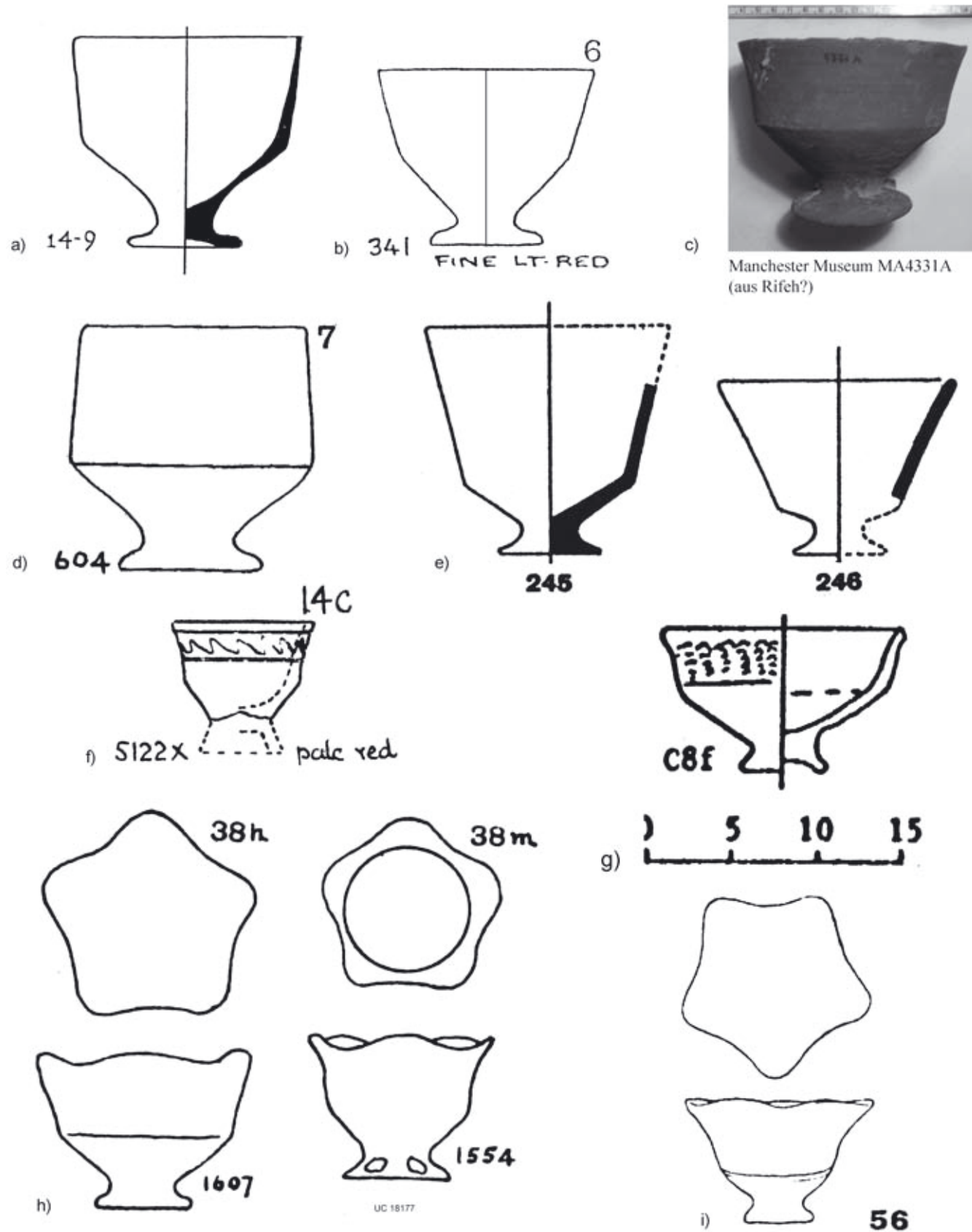

„Kelche“: a) FAKHRY, *Dahshur II*, 124, 14/9; b) BRUNTON/ENGELBACH, *Gurob*, Pl. XI/6; c) Manchester MA4331A; d) PETRIE, *Kafr Ammar*, Pl. 27/7; e) KAISER, *Userkaf II*, 76, 245, 246; f) BRUNTON, *Mostagedda*; Grab 5122; g) SLATER, *Denderah*, C8f; h) PETRIE, *Sedment I*, Pl. 30.3; i) GARSTANG, *Burial Customs* (Beni Hassan), Pl. XV, 56

Abb. T32 Kelche: Vergleichsstücke



Tiefe Schalen mit Innentasche und Handhabe (18)

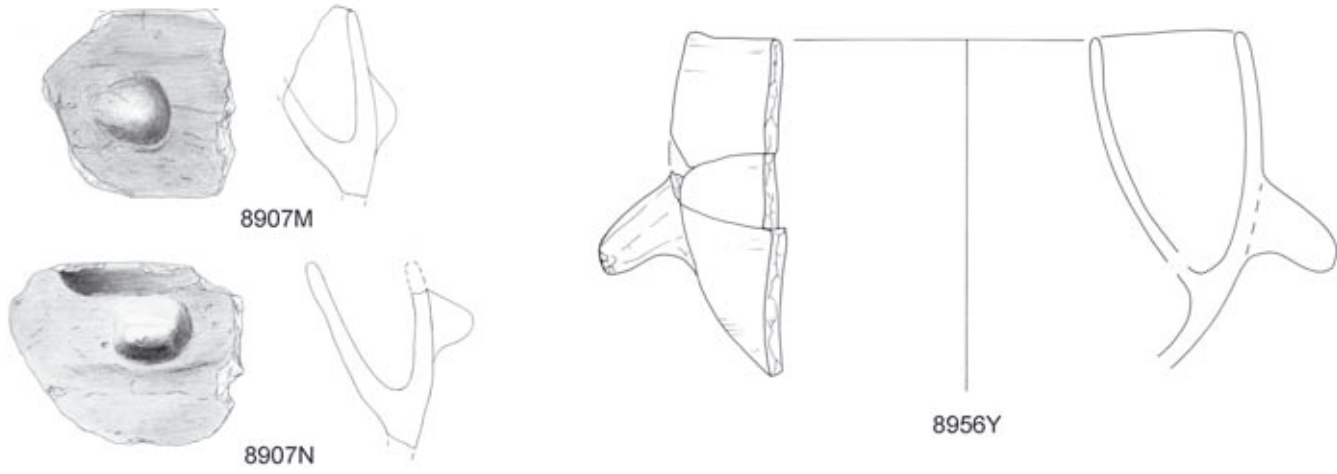

Kleine offene Töpfe mit verdicktem Rand und flachem Boden (19)

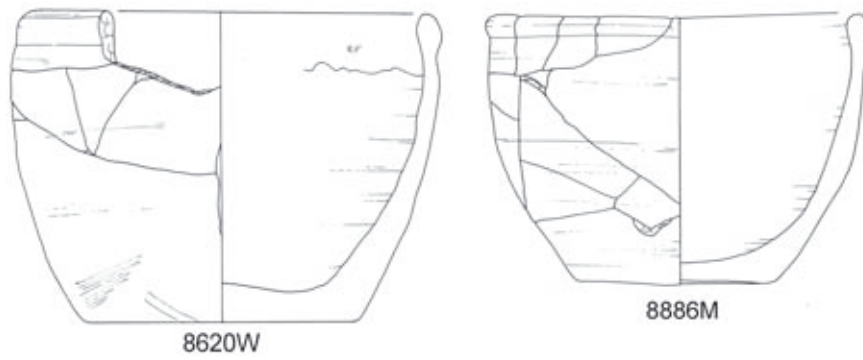

Kleine offene Töpfe mit eingezogener Schulter und Ausgusstülle (21)

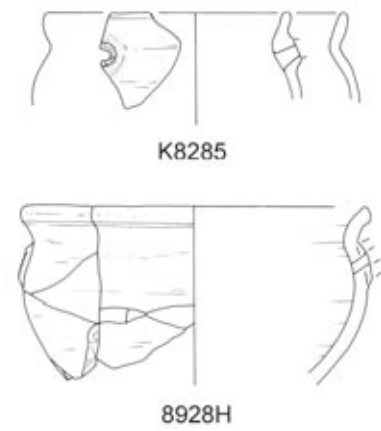

Große Schüsseln mit eingezogener Schulter und Außenlippe (20)

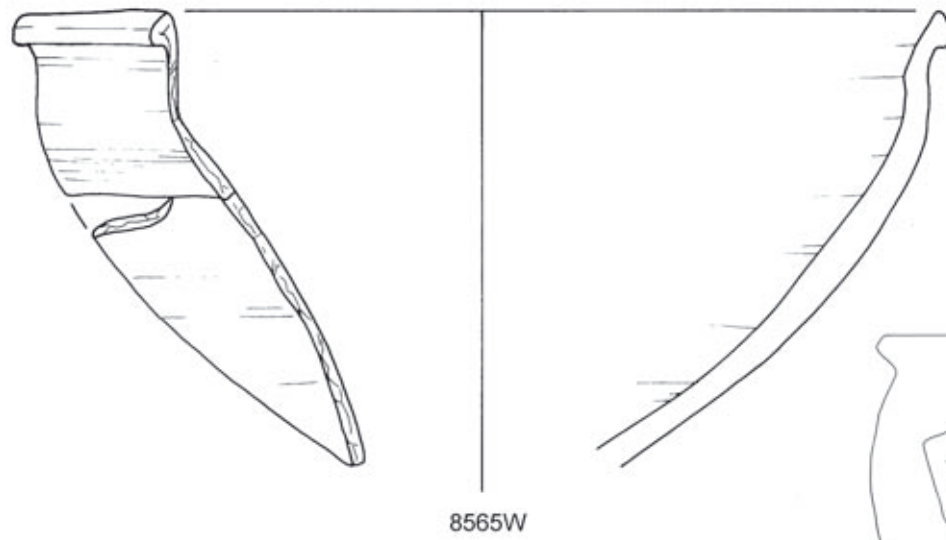

Mittelgroße offene Töpfe mit eingezogener Schulter und Standboden (22)

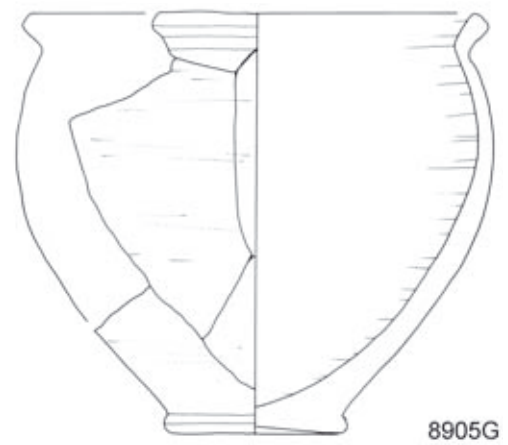

Knickwandschälchen mit dekoriertem Rand (23)



Abb. T33

## Fußschalen mit hohem geschlossenem Fuß (24)



8899R

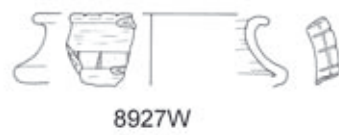
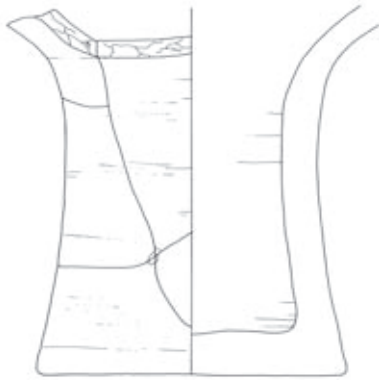
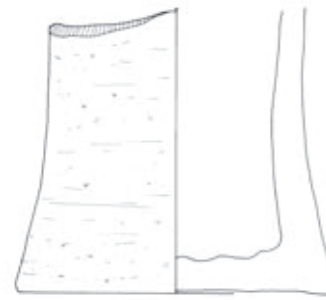

8617Q

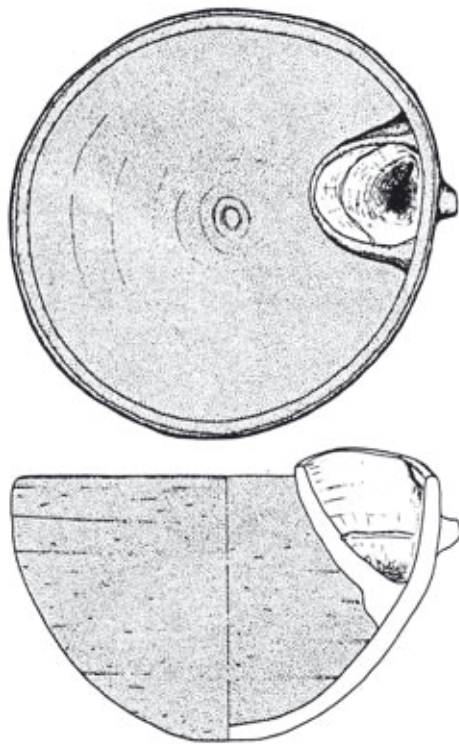

a) von PILGRIM, Elephantine 18, Abb. 154i

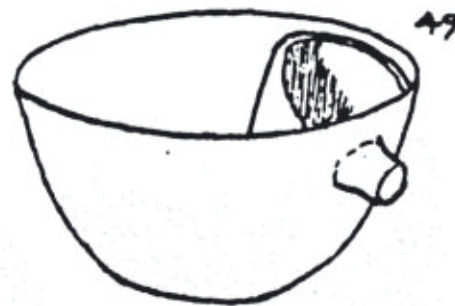

b) PETRIE, KGH, pl. 13/49 = MAN 432

Abb. T34 Tiefe Schalen mit Innentasche und Handhabe, Vergleichsstücke

Kugelige Vasen mit einfachem Rand (25)



K7565

Kugelige Vasen/Töpfe mit Wulstrand (26)

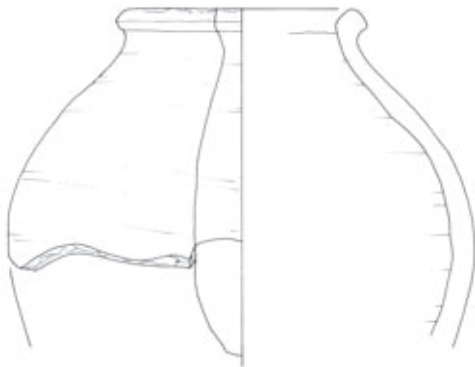

8906V

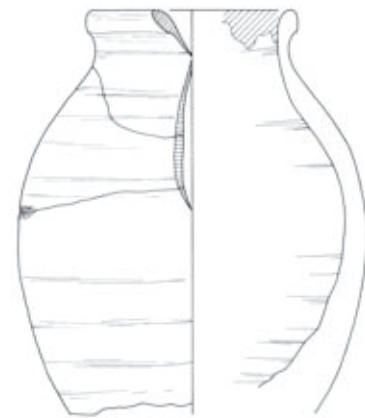

8617P

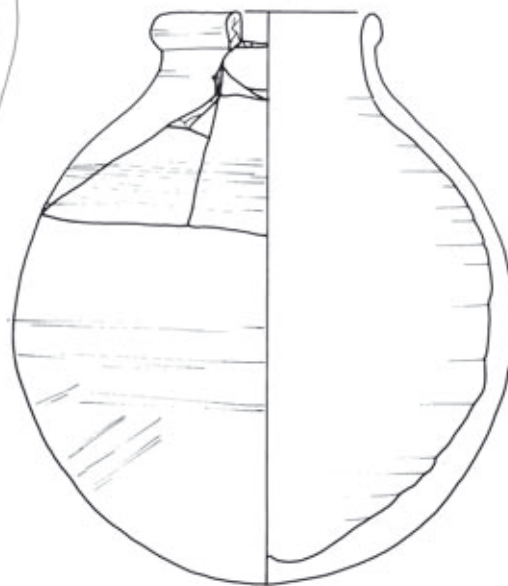

8892O



8643O

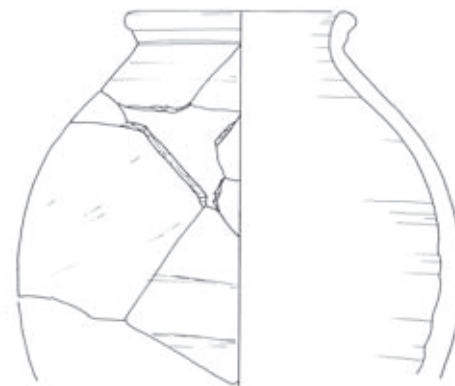

8899H

Abb. T35

Kugelige Vasen/Töpfe (Körper) (27)



8898A

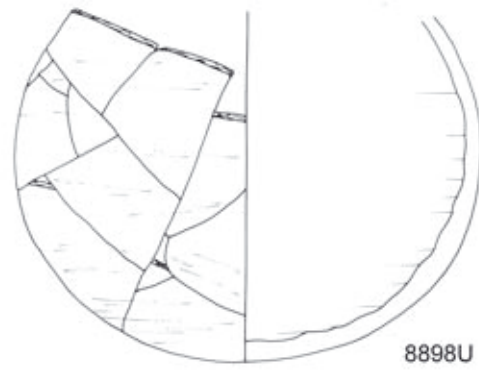

8898U

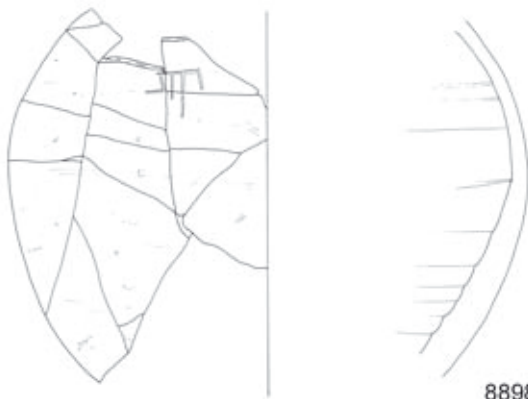

8898L

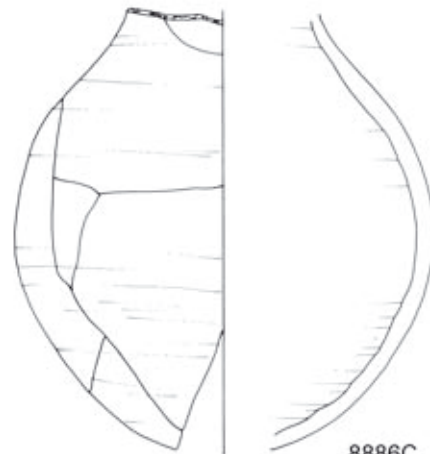

8886C



8888T

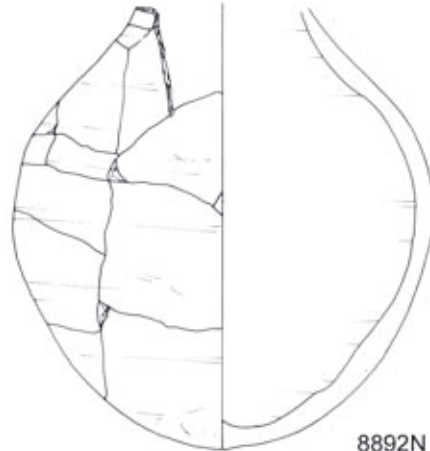

8892N

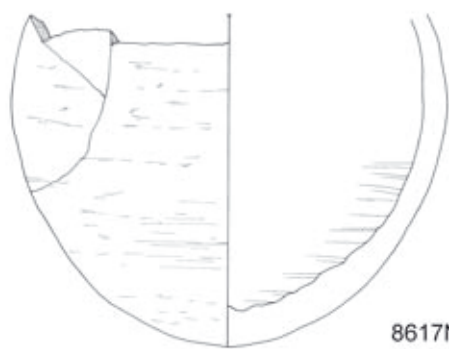

8617N

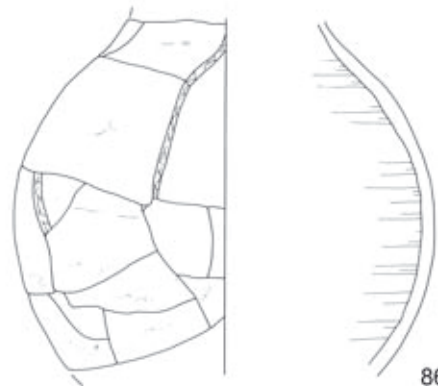

8617O

Abb. T36

Kugelige Vasen/Töpfe (Körper) (27) f.

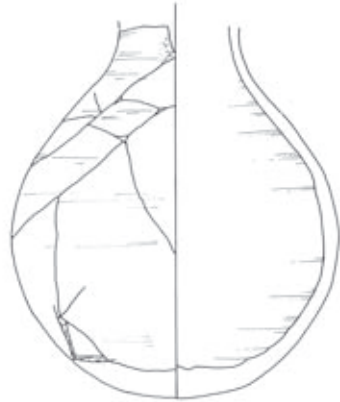

8617K

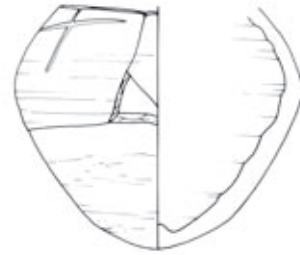

8898V



8900P



8898B

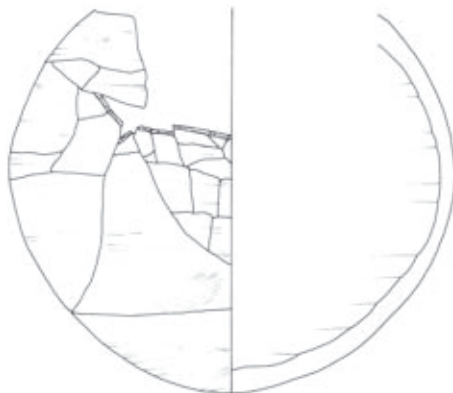

8897T



8555T

Töpfe mit Randleiste (28)



K7516

Abb. T37

Henkelkrüge (29)



Abb. T38

Schalen mit geschwungener Kontur, klein (30)



Schalen mit geschwungener Kontur, groß (31)

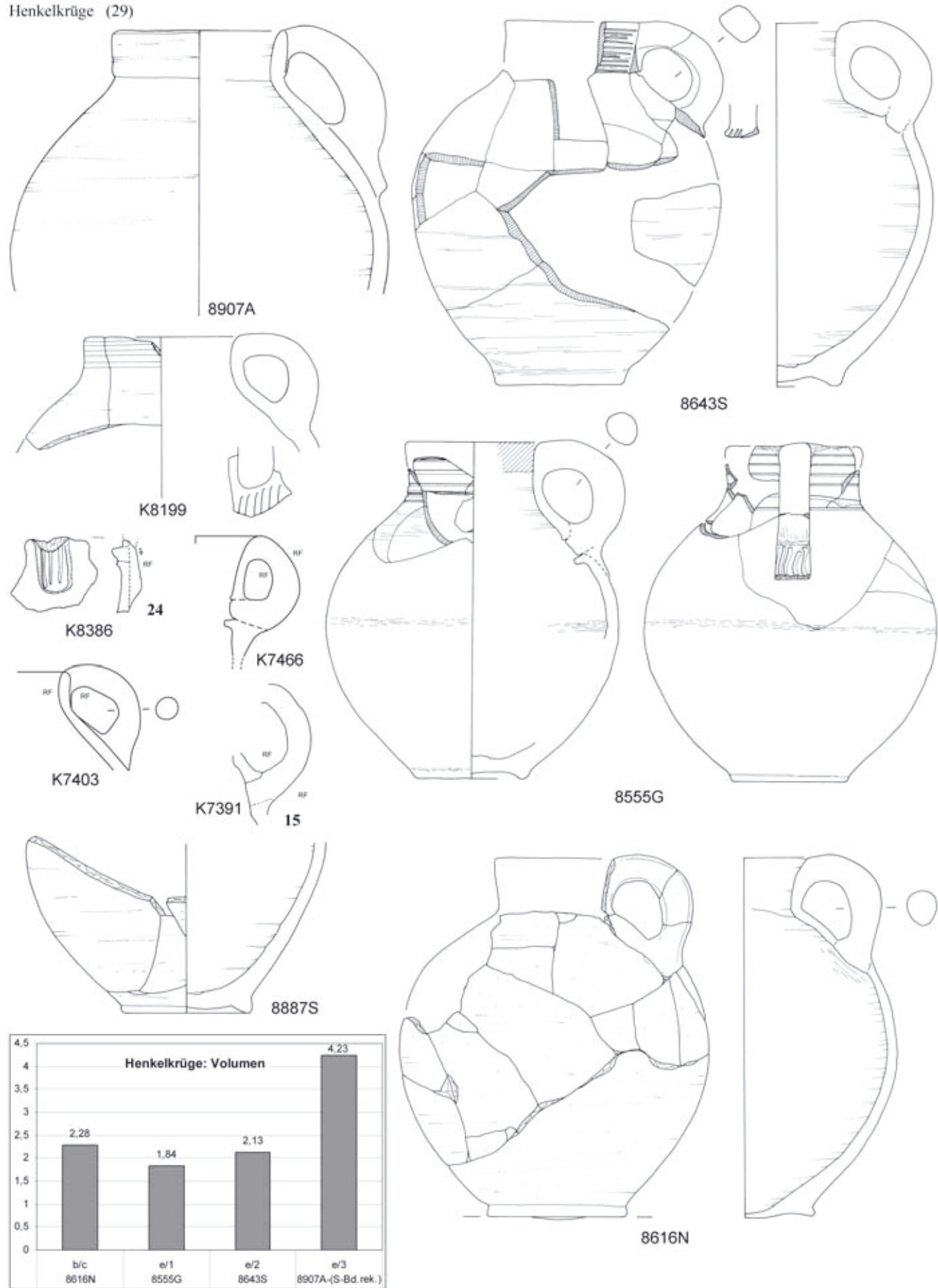
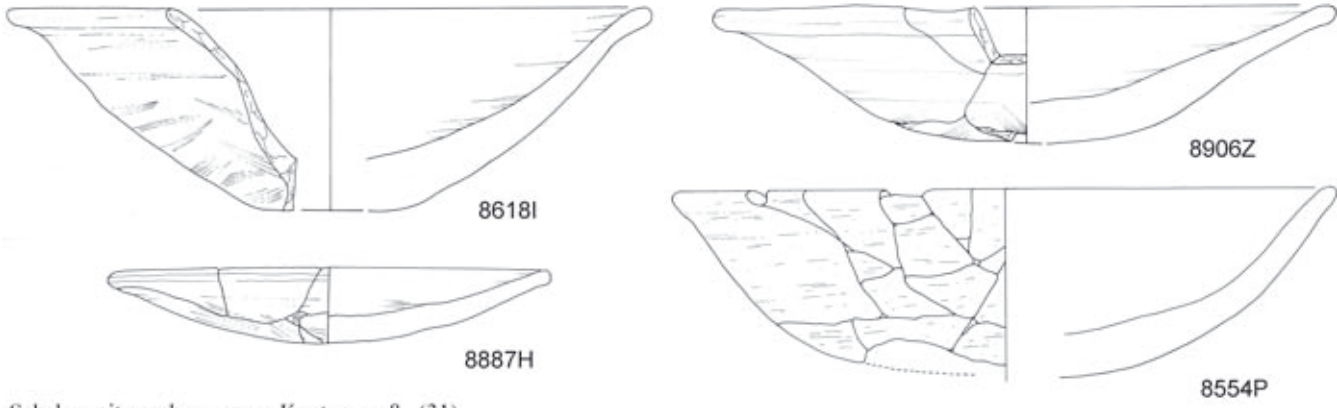

Abb. T39

Schalen mit geschwungener Kontur, groß (31) f.



8569R

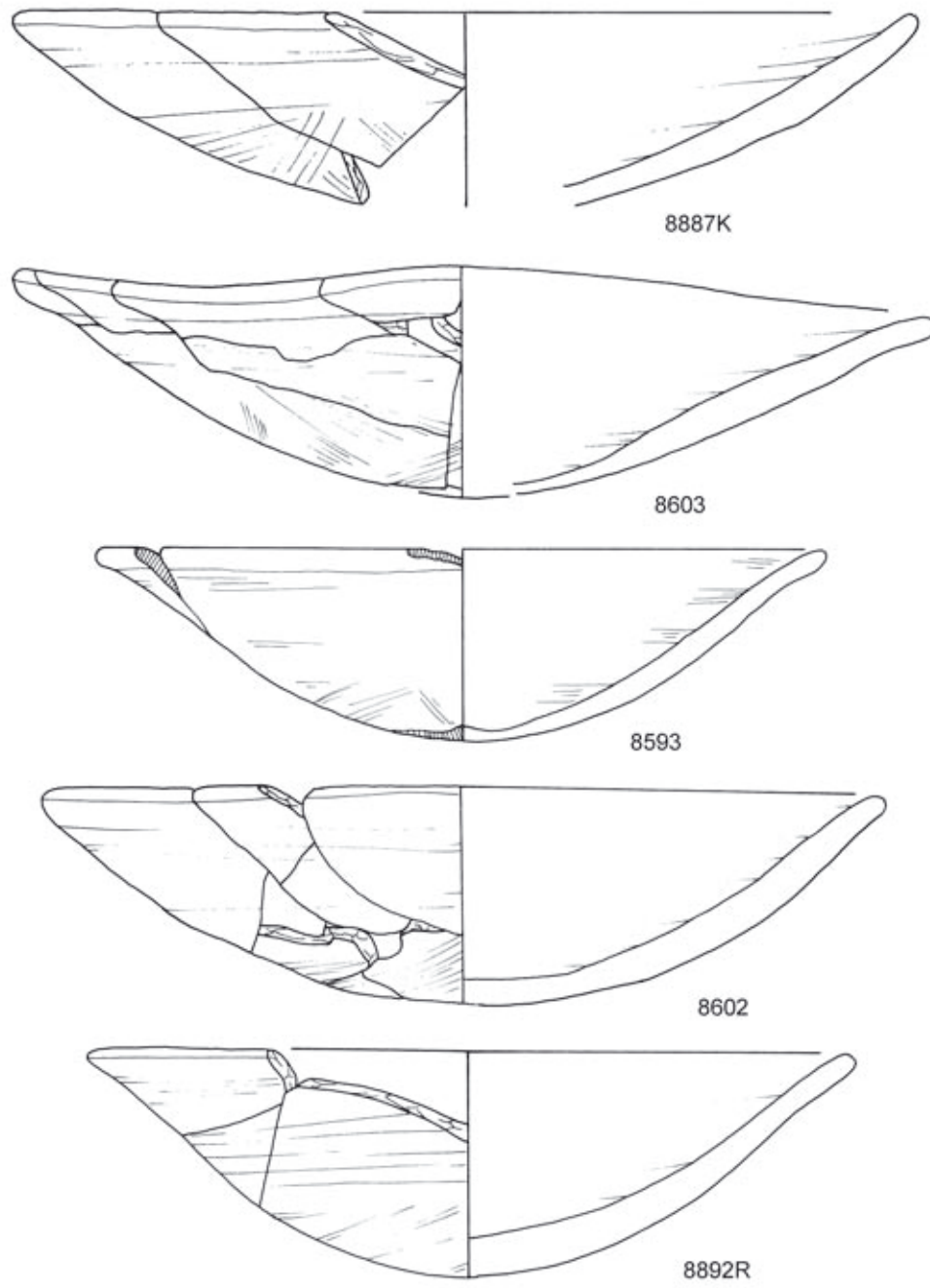
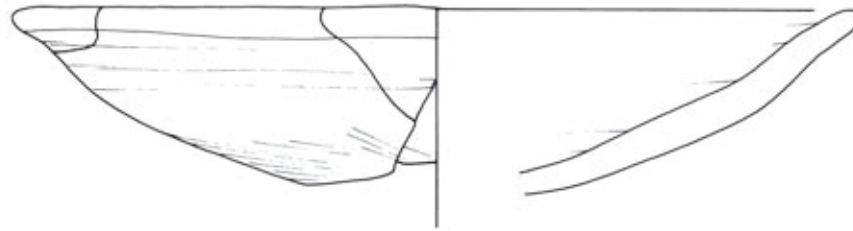
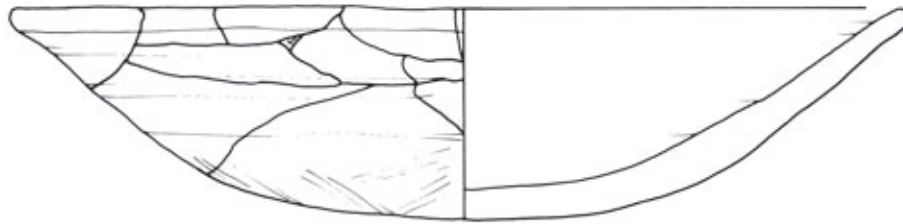

8899Q

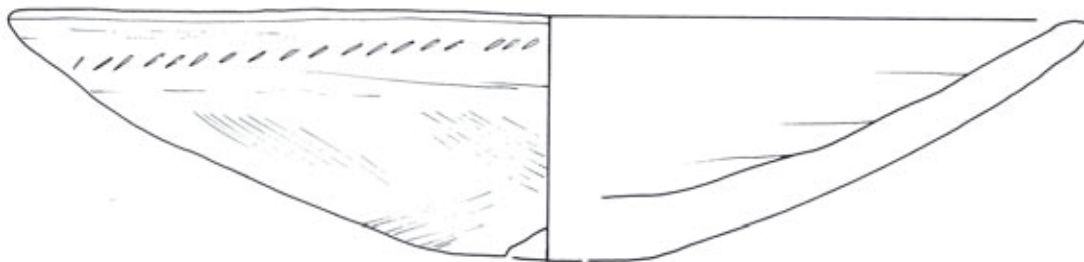

8898C

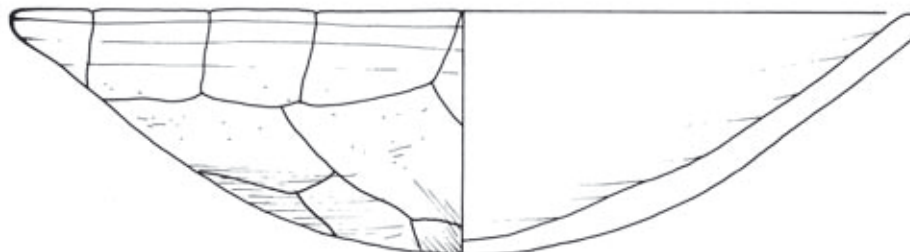

8897P

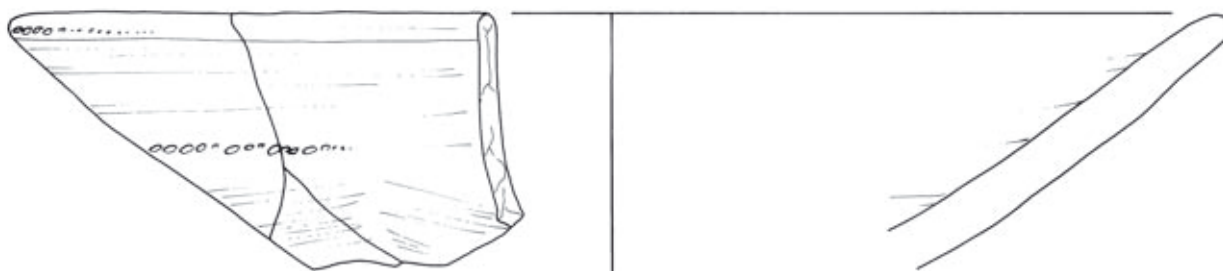

8565A

Abb. T40



Schalen mit geschwungener Kontur, groß (31) ff.



Abb. T41

## Große Schalen mit einfachem Rand und flachem Boden (32)



8900C

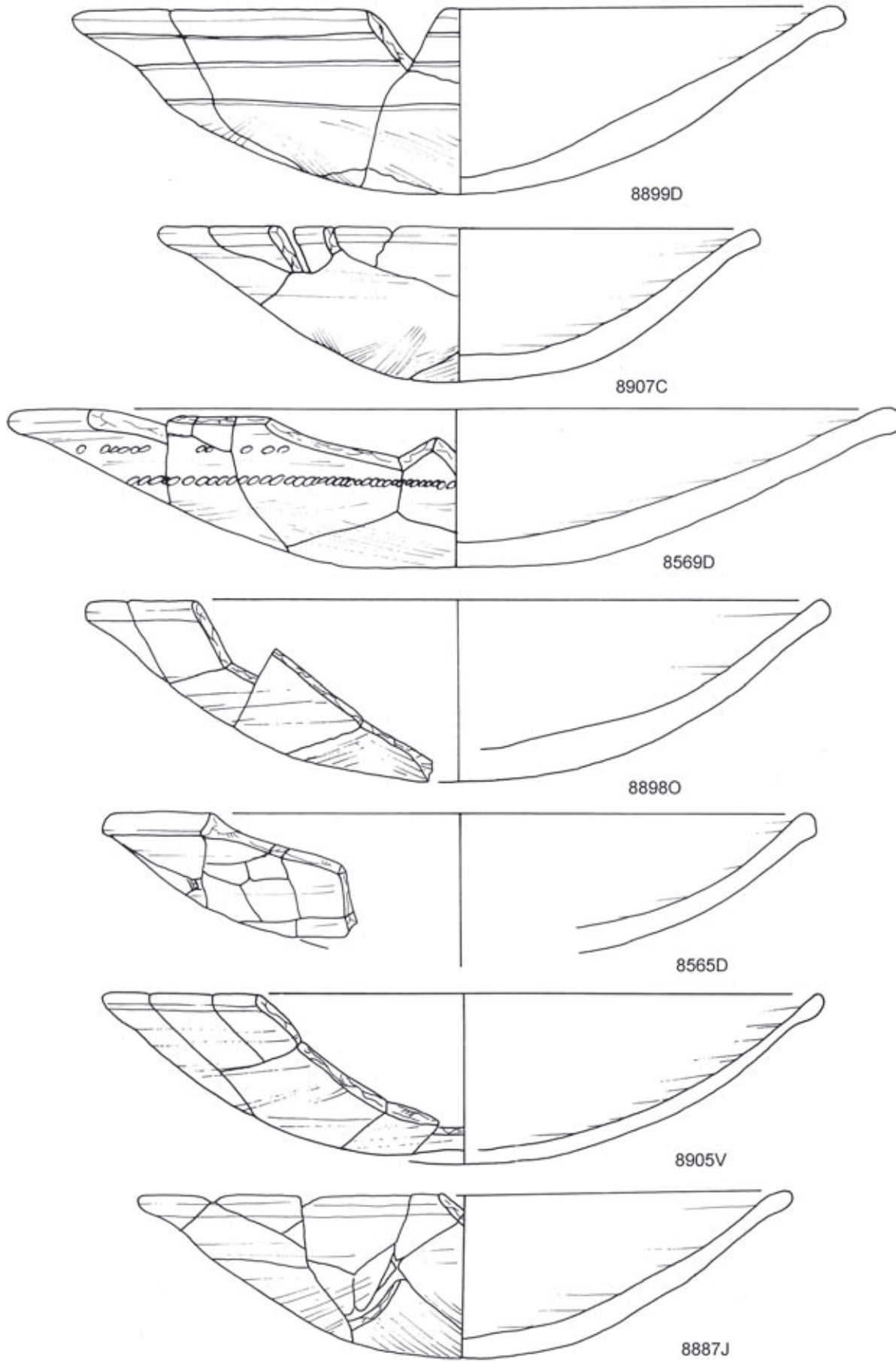
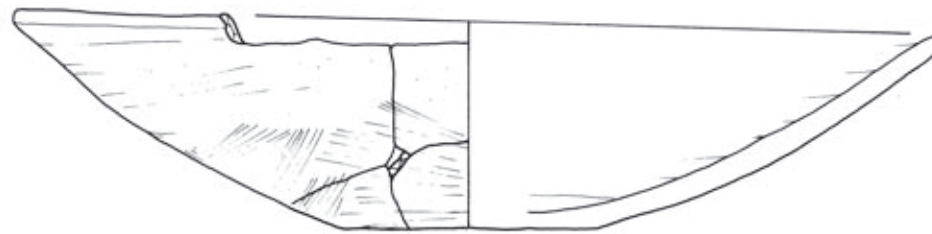
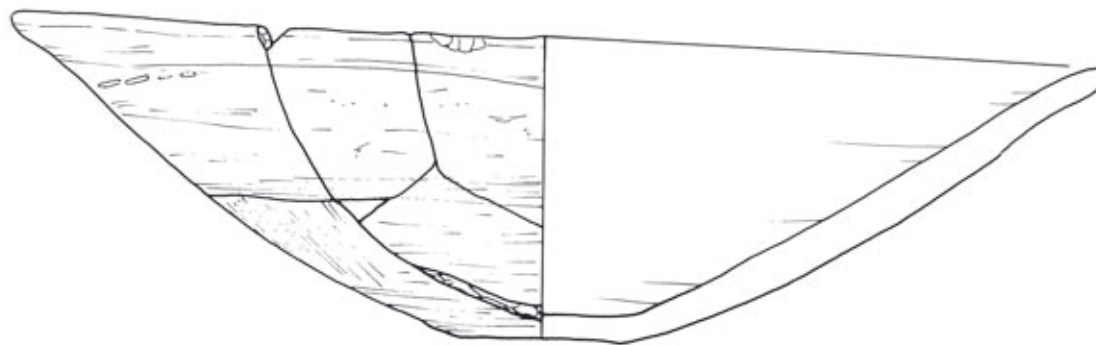

8898I

## Große Schalen mit verdicktem Rand und Standboden (33)

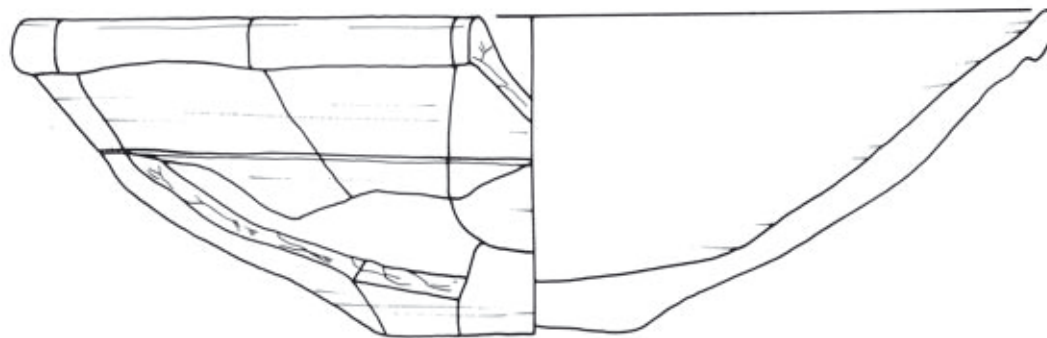

8899A

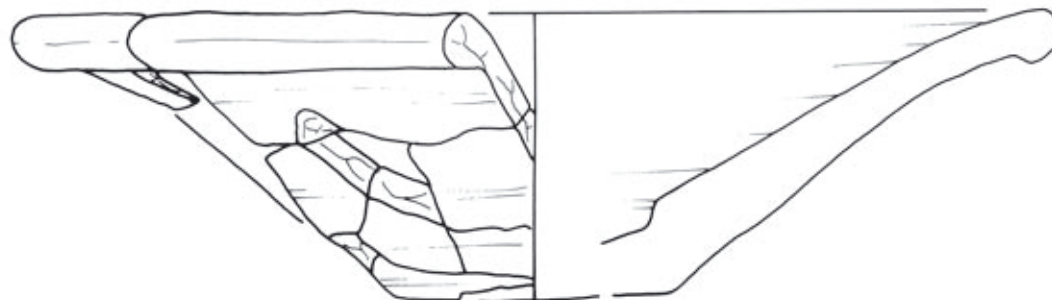

8899C

Große Schalen mit Innenlippe und flachem Boden (34)

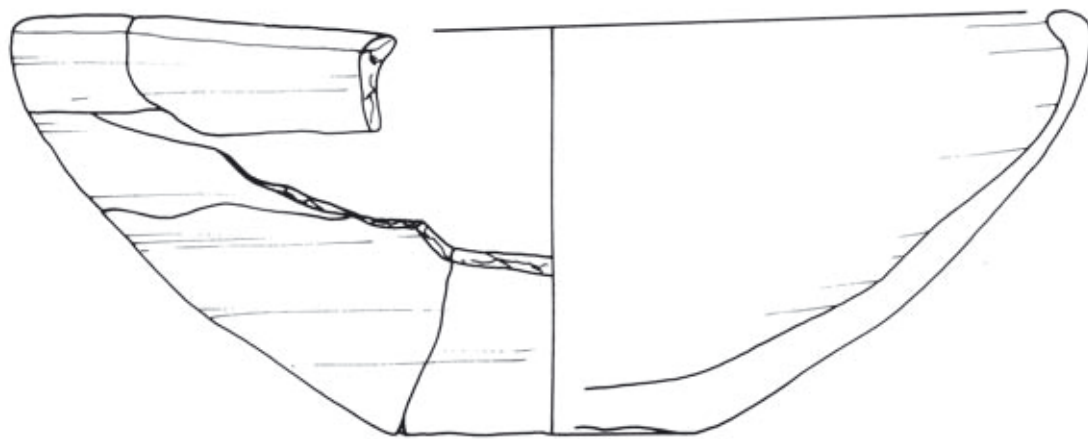

8886U

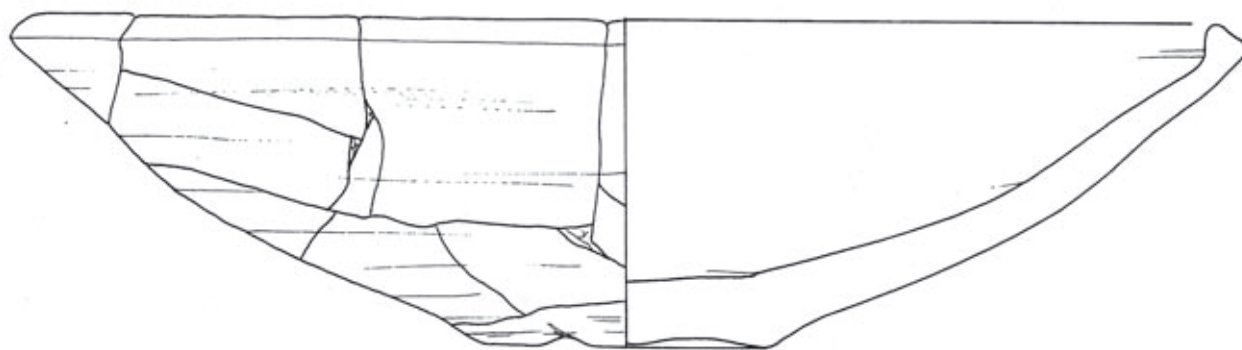

8905S

Abb. T43

Fußschalen mit niedrigem geschlossenem Fuß (35)



Abb. T44



8887Q

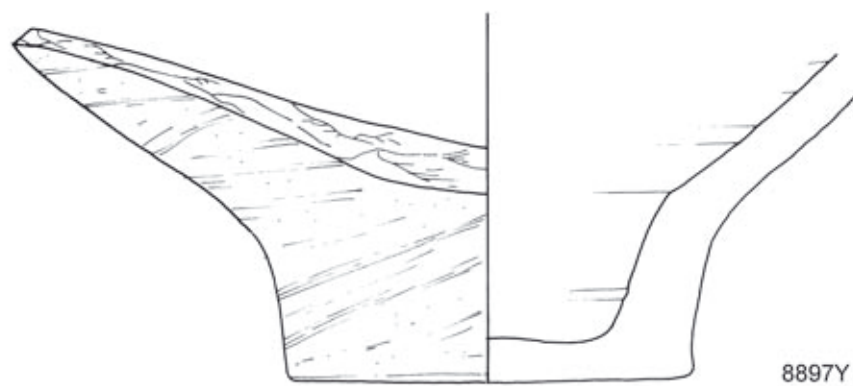
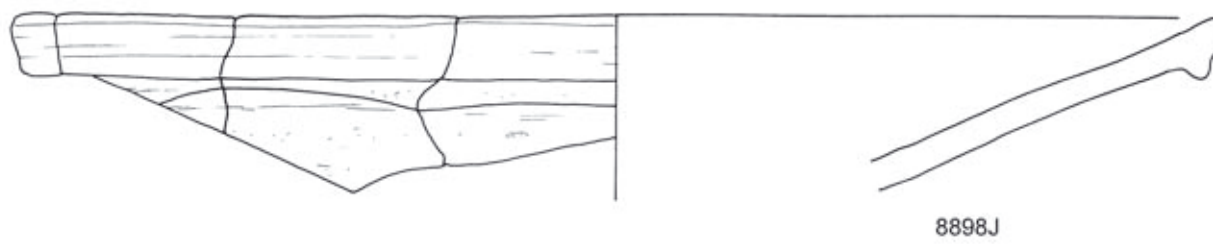
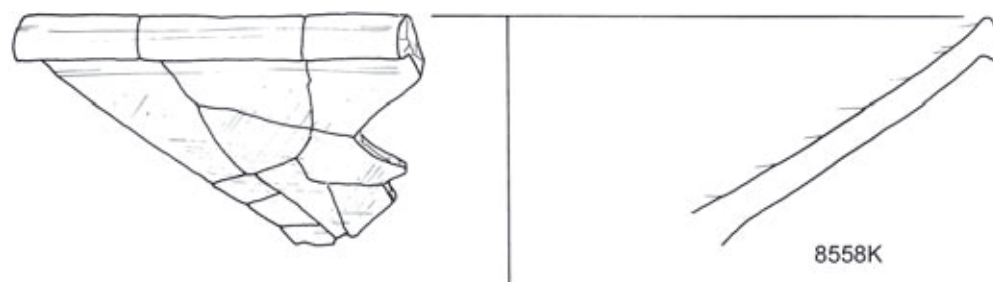
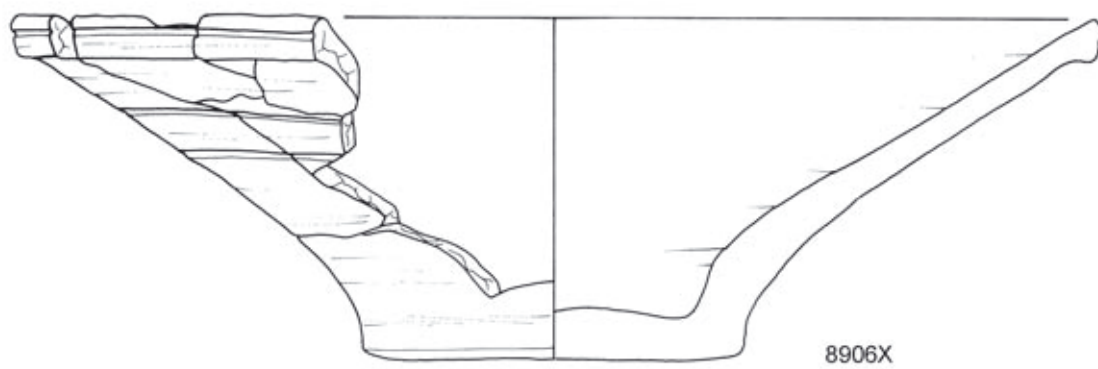
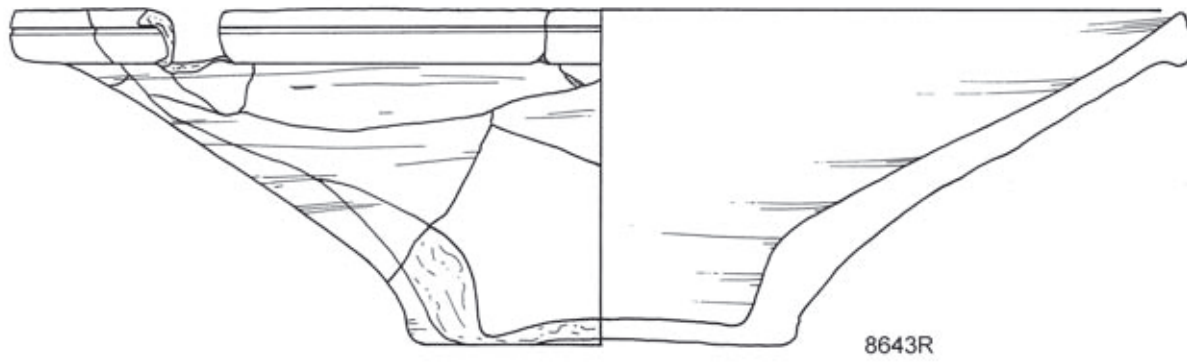
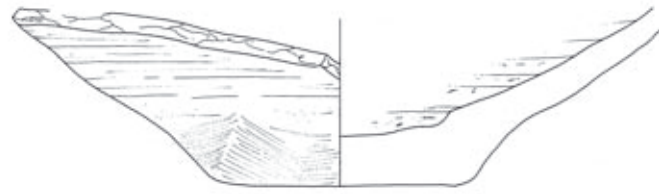
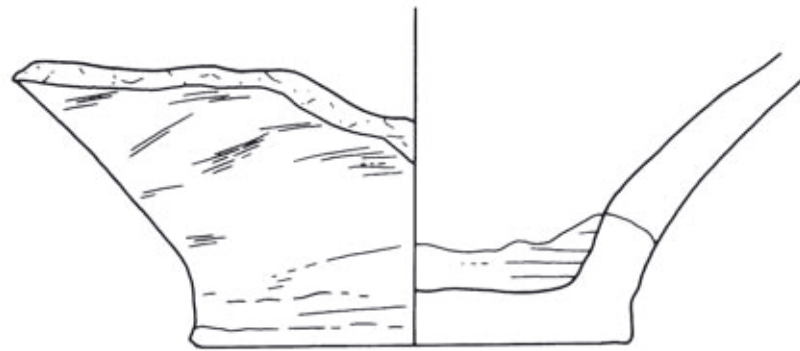

8620X

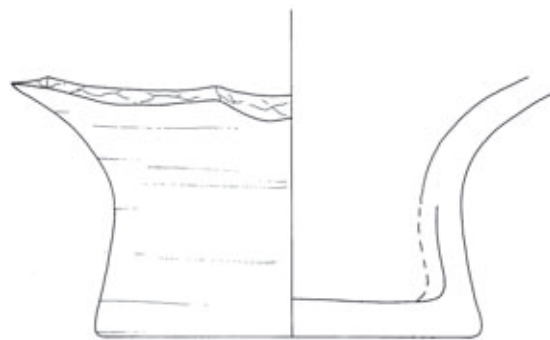

8569N

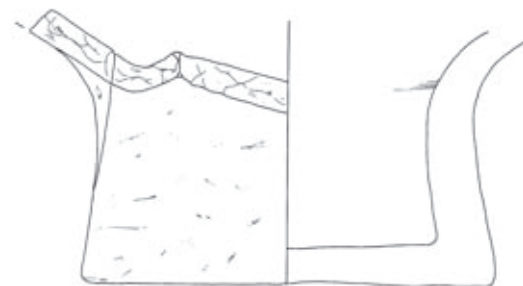

8898D

Abb. T45

Halbkugelige tiefe Schalen mit Rillendekoration im Randbereich, groß (36)



Abb. T46



Einfache Schalen/Schüsseln mit flachem Boden (37)

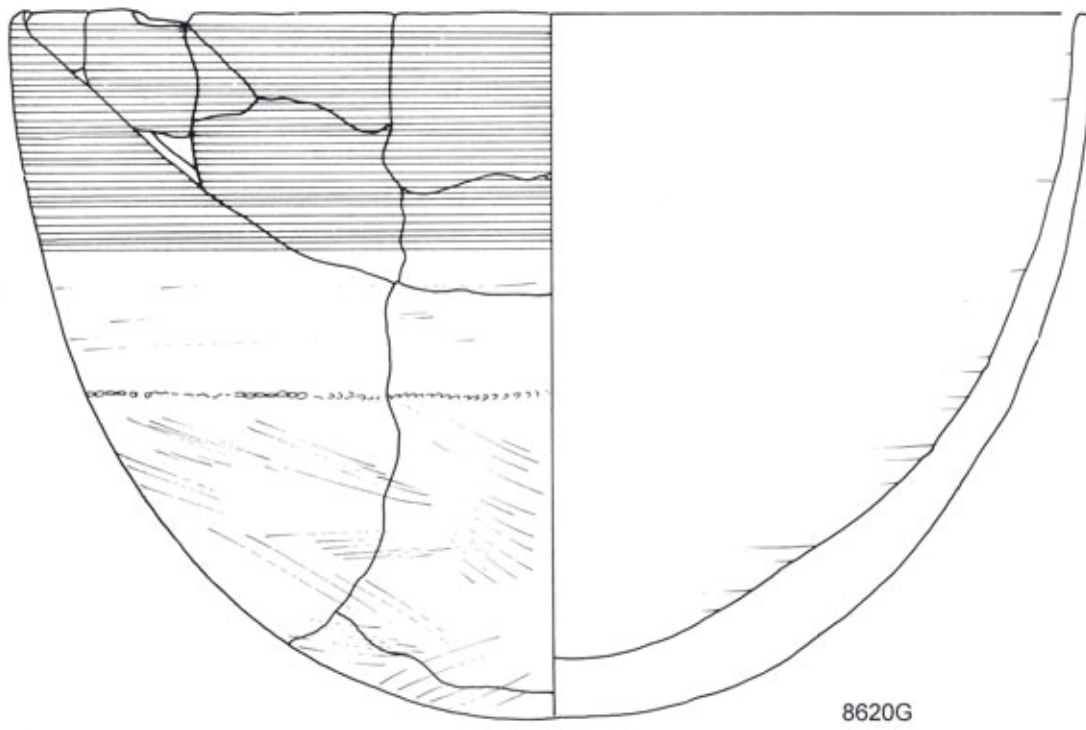
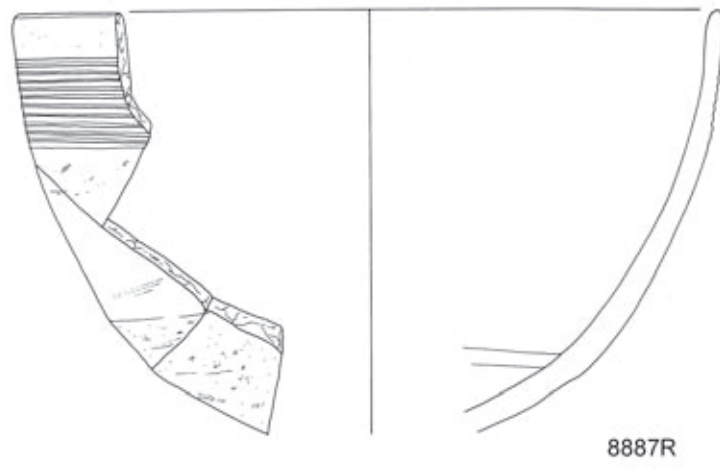
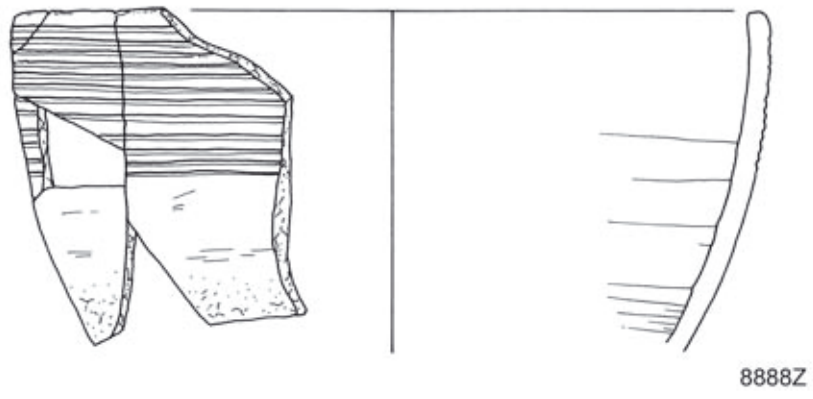
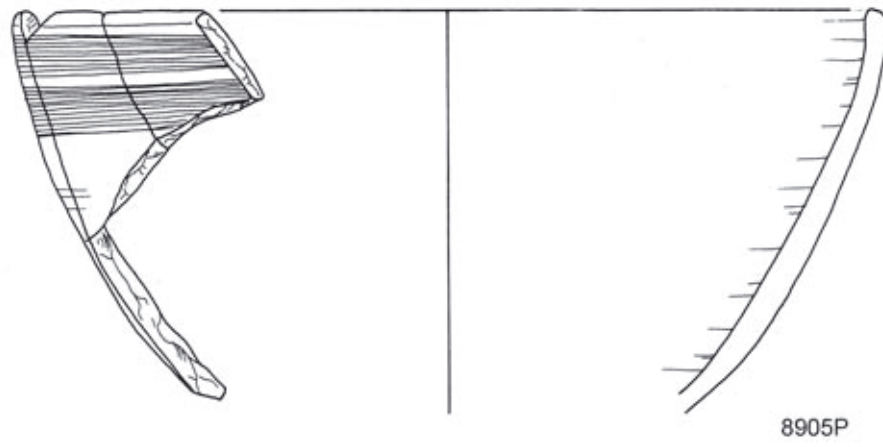
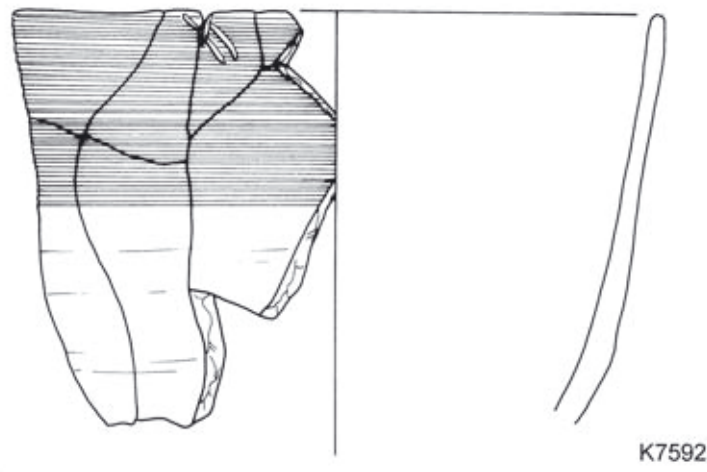
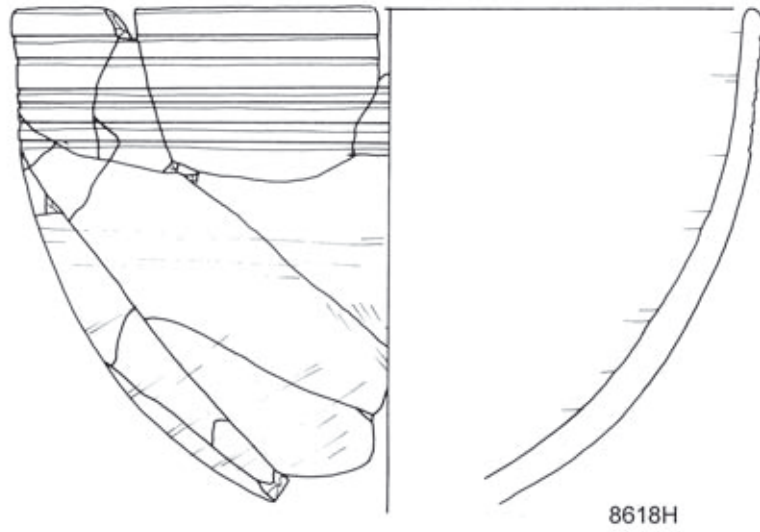

Abb. T47

Tiefe Schalen/Schüsseln mit verdicktem Rand/Wulstrand (38)



Tiefe Schalen/Schüsseln mit verdicktem Rand und Standboden (39)

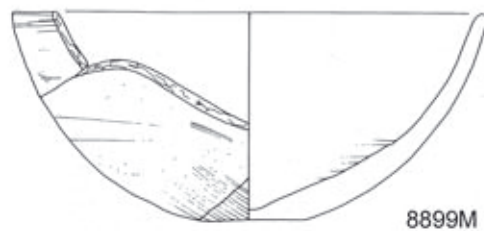
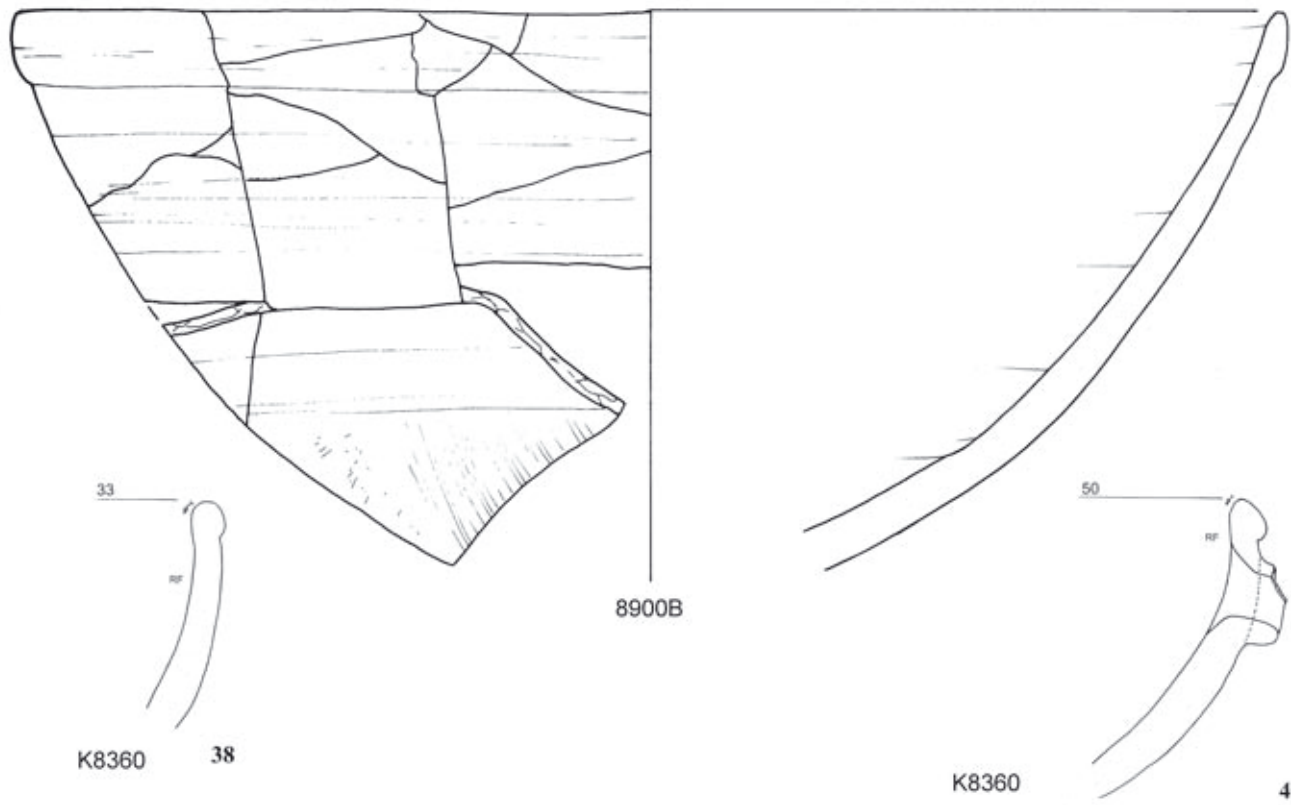
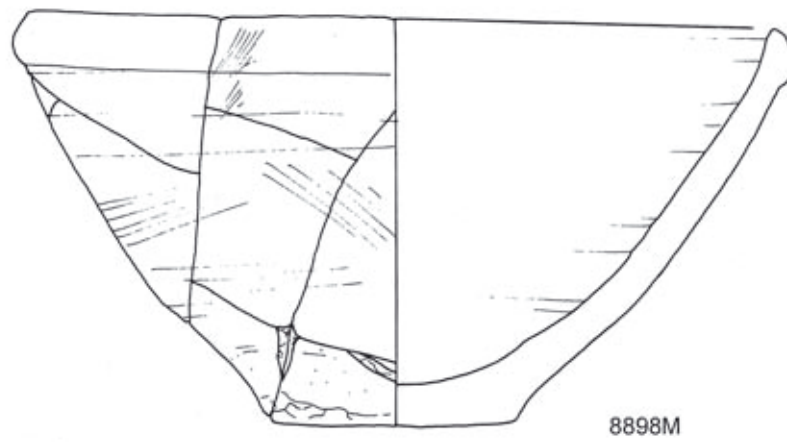

Mittelgroße offene Töpfe mit eingezogener Schulter und Wulstrand (40)

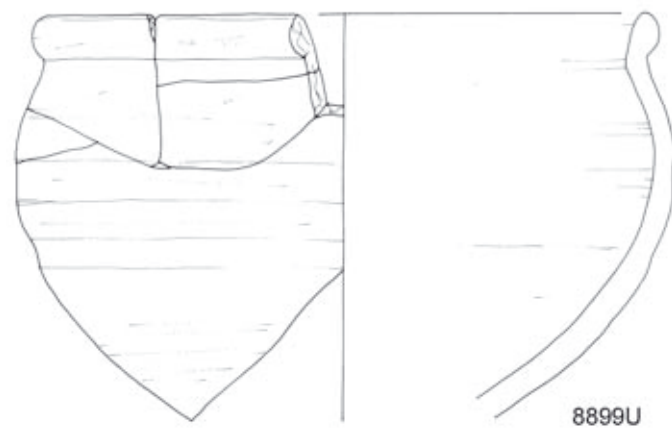

Töpfe mit eingezogenem Wulstrand (41)





Große Knickwandschalen mit Ritzdekor (42)



K8176

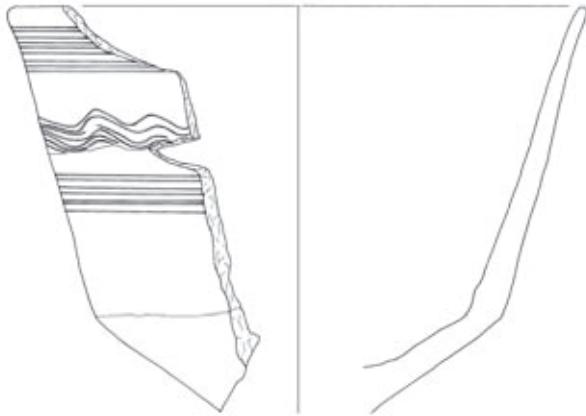

K8246

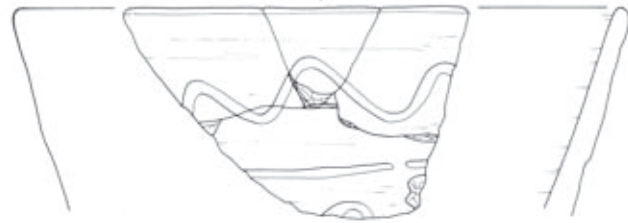

8906T

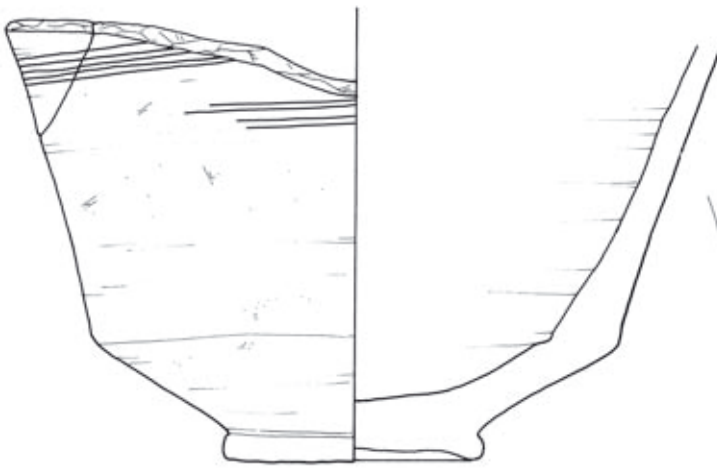

8897Z

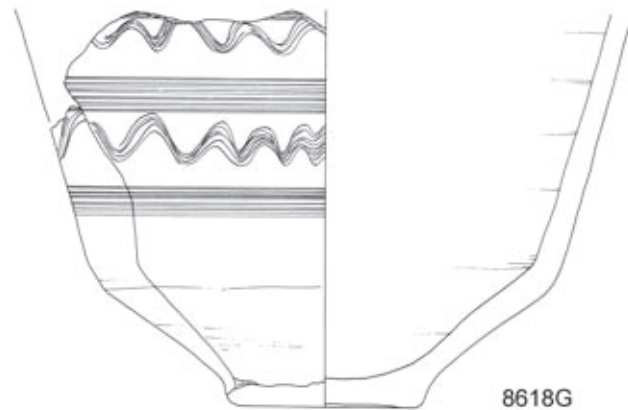

8618G

Abb. T49

Große Knickwandschalen mit Ritzdekor (42) f.



Abb. T50



1) Frühe 12. Dynastie: Tell el-Dab'a F/I, str. e

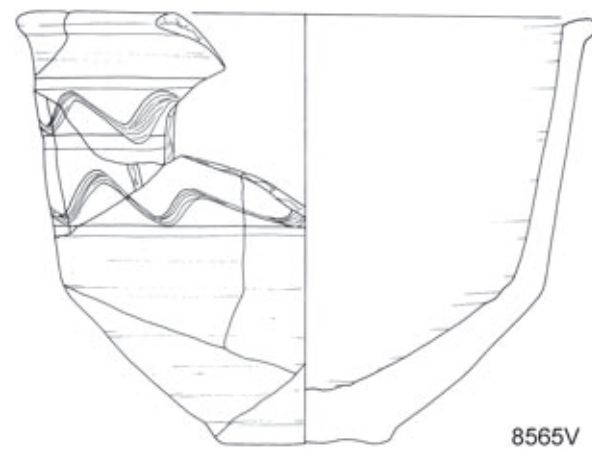
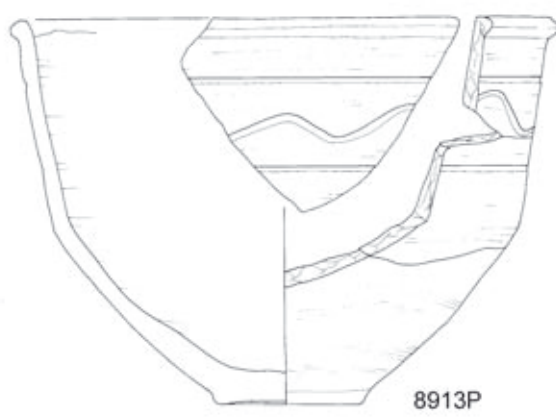
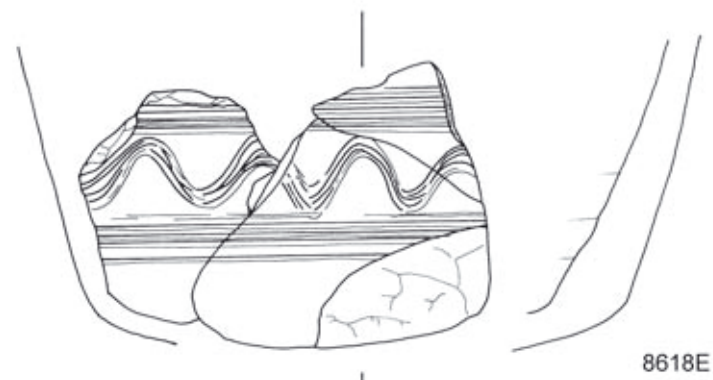
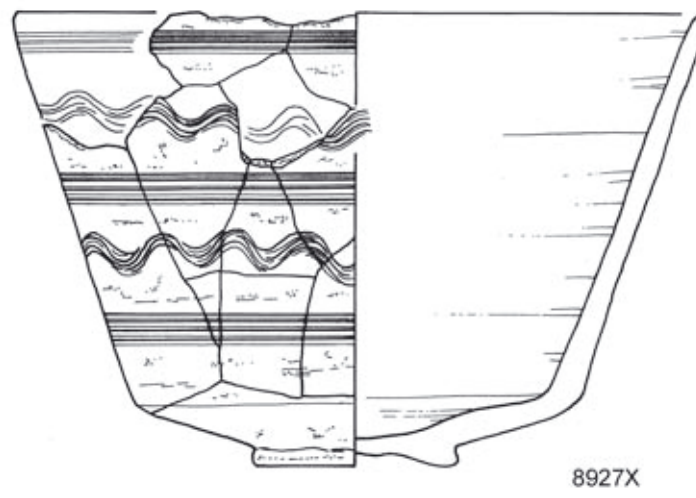
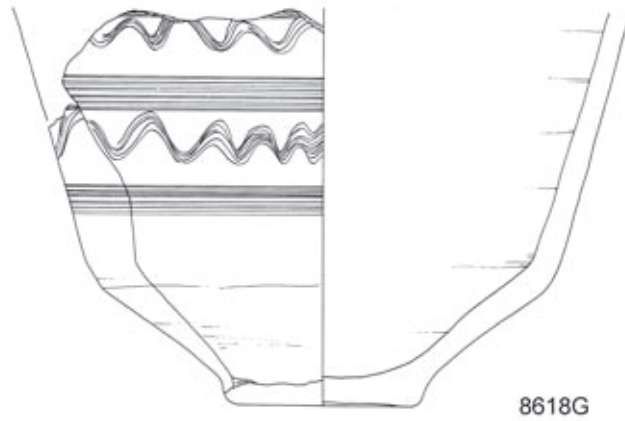
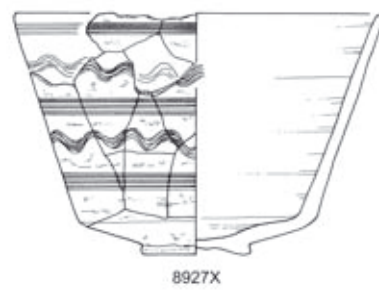

2) Mittlere und späte (?) 12. Dynastie

a) Ezbet Rushdi, Siedlung

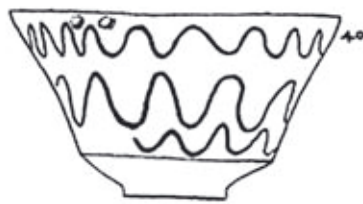

b) Kahun, *KGH*, Pl. XIII, 40



c) Kahun, Manchester Museum

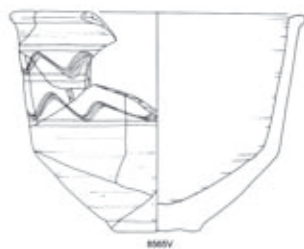

3) 13. Dynastie und 2. Zzt.

a) Ezbet Rushdi, str. a (Ph. E/2-E/3)

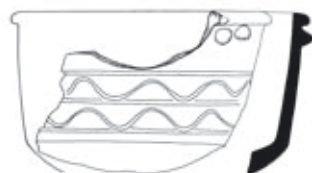

b) Tell el-Dab'a, c. Ph. F-E/2 (ASTON, *TD* 12, 133)

Abb. T51 Große Knickwandschalen mit Ritzdekor: Entwicklung

Bechervasen mit Rundboden (43)



Abb. T52

Bechervasen mit flachem Boden (44)



8898R

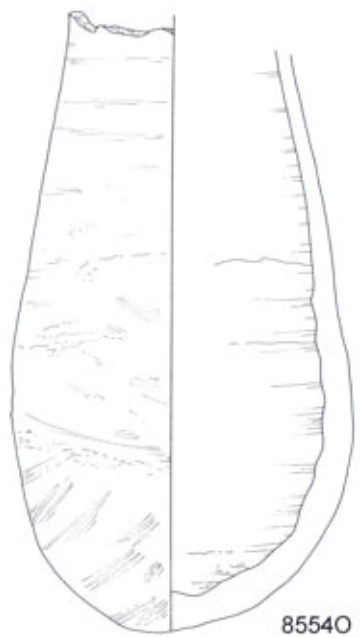
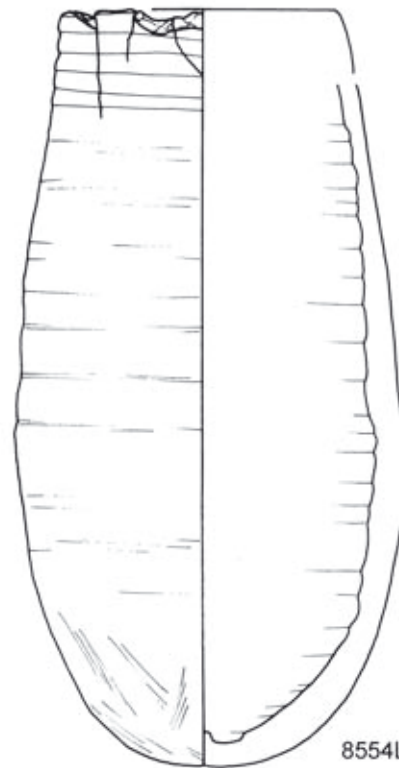
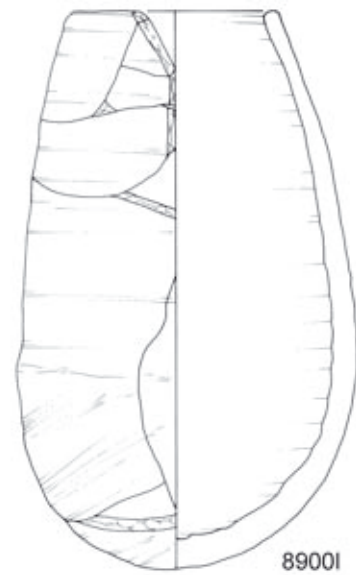
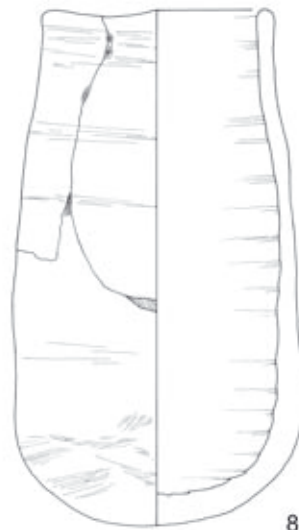
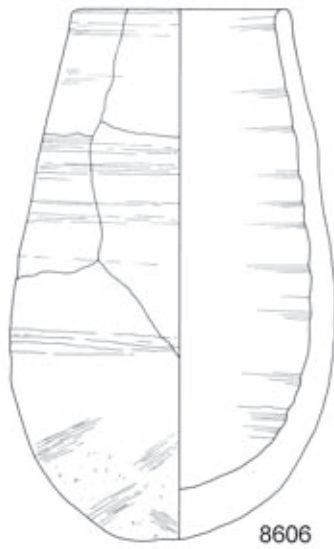
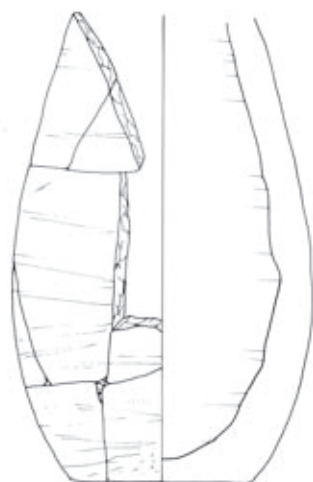

8569F



8885K

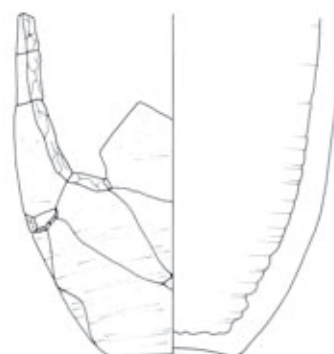

8905N

Abb. T53

Flaschen/Vasen mit einfachem Rand (45)

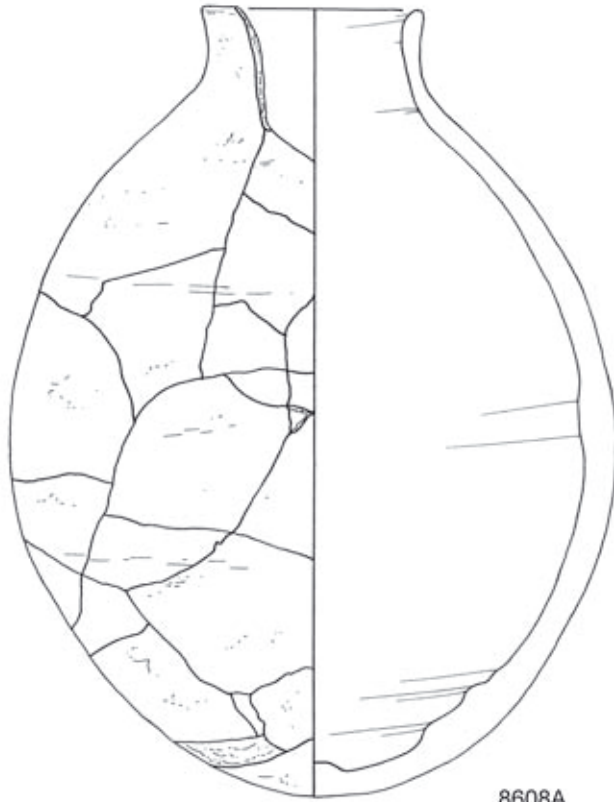

8608A

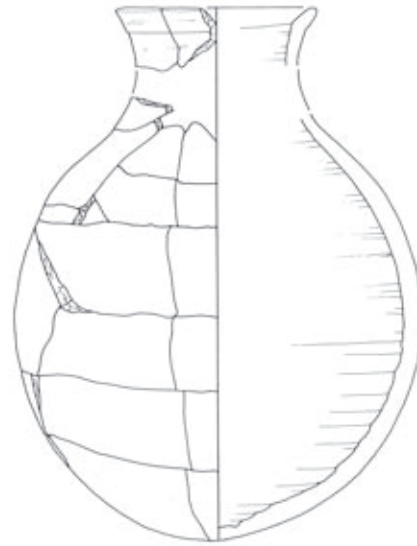

8617L

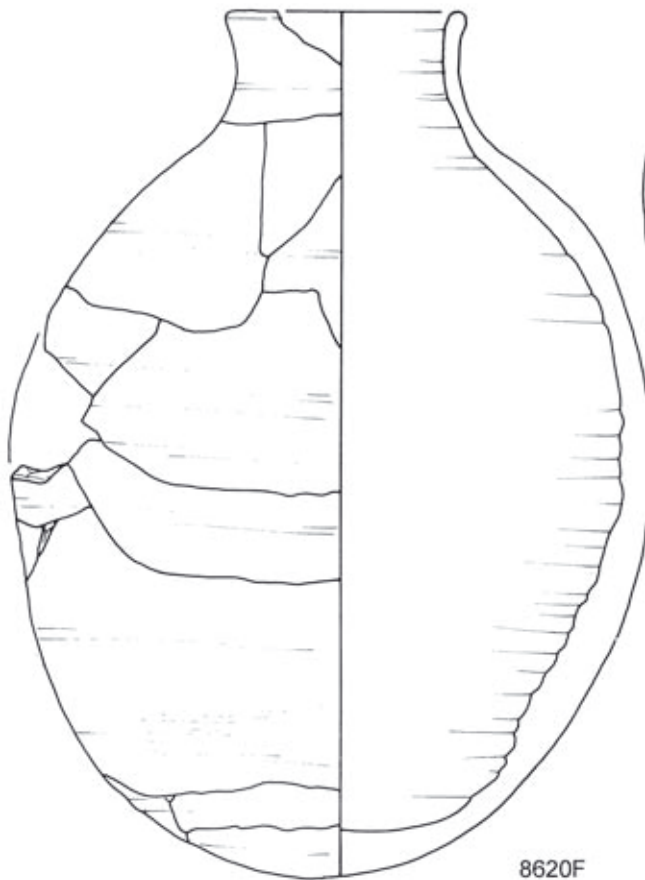

8620F

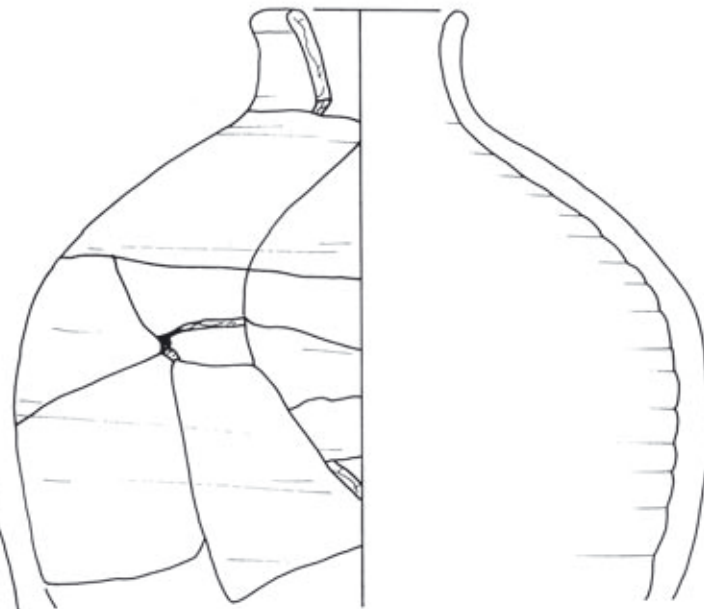

8569C

Abb. T54

Flaschen mit Wulstrand (46)



Abb. T55

Flaschen mit Kesselmündung (47)



K8424

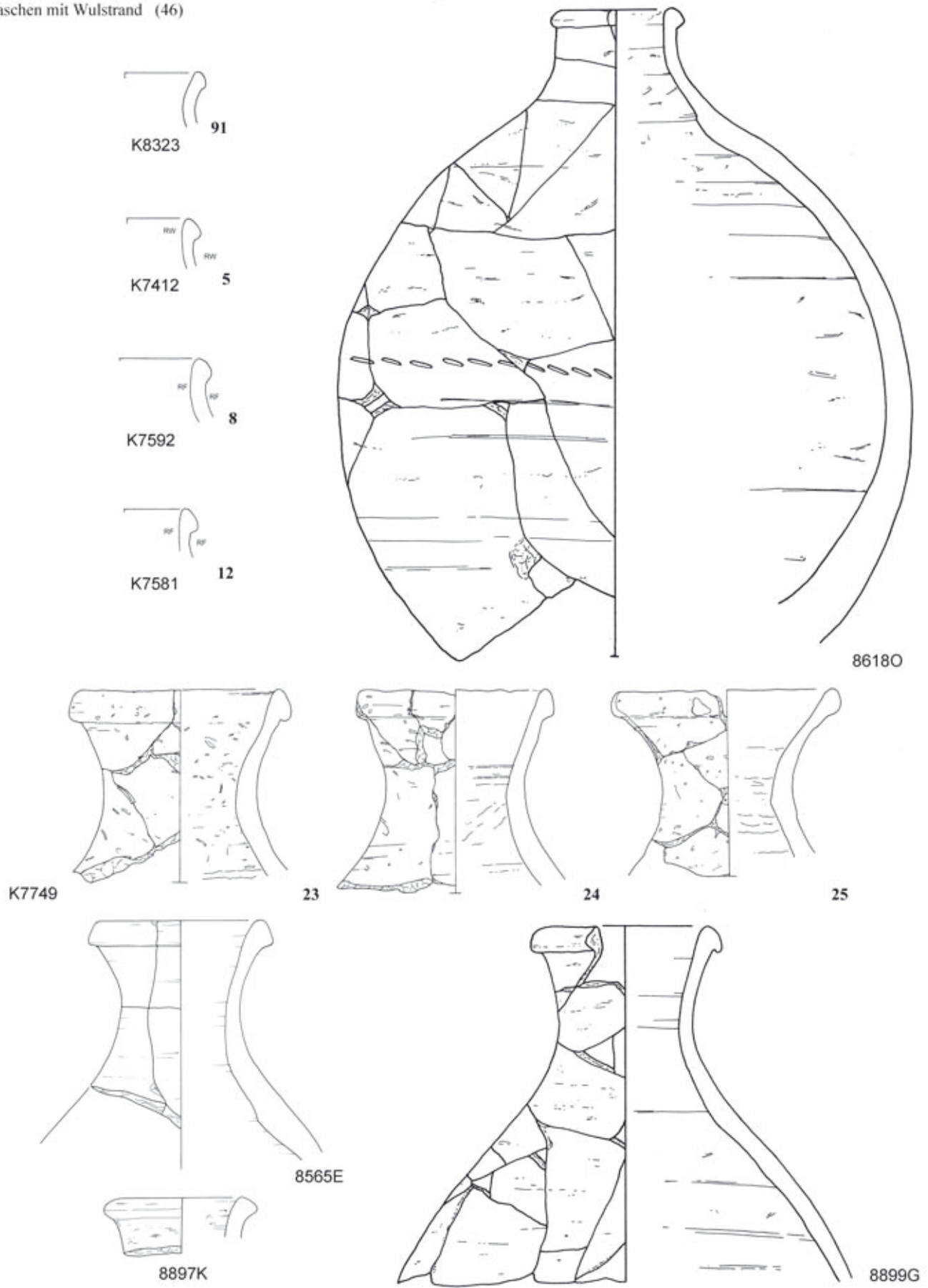
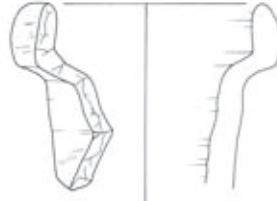

K8424

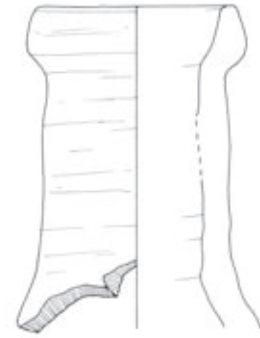

84940

Körper von Bierflaschen (48)

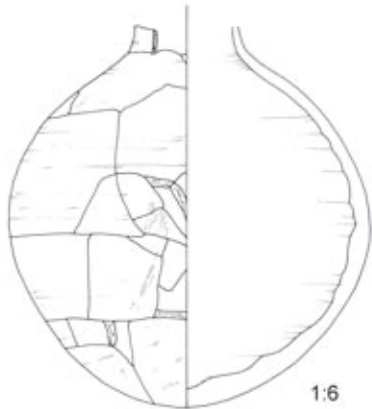

8897O



8892T

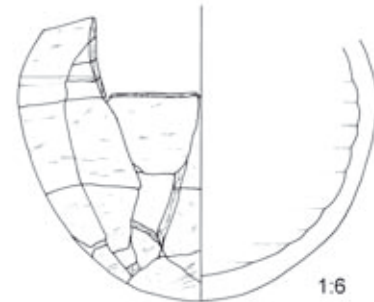

8897Q

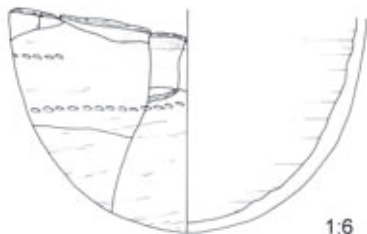

8897X



8886D

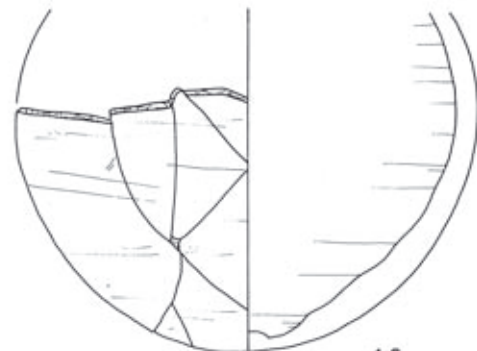

8886S

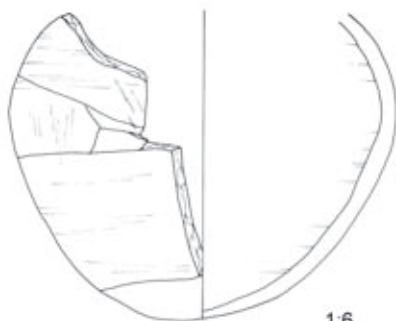

8892X



8897N



8897L

Abb. T56



Körper von Bierflaschen (48) f.



Abb. T57

Körper von Bierflaschen (48) ff.

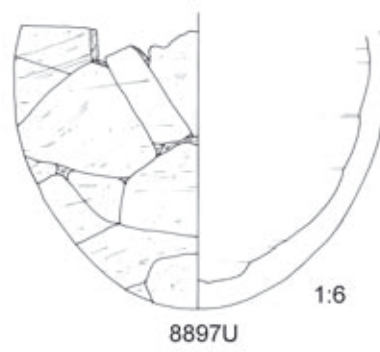
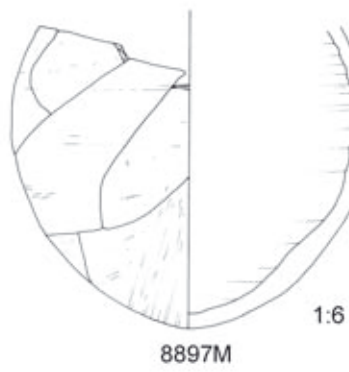
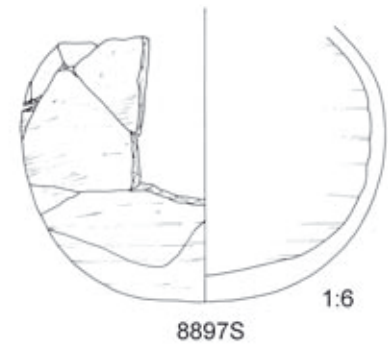
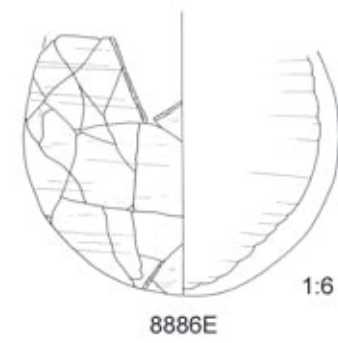
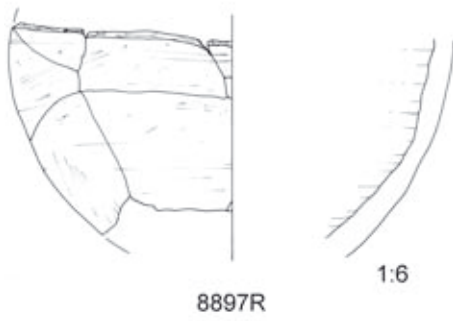
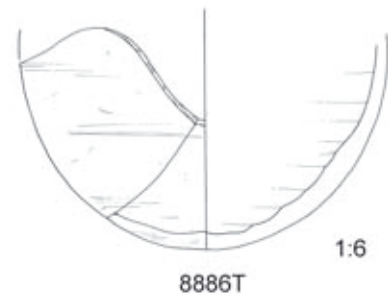
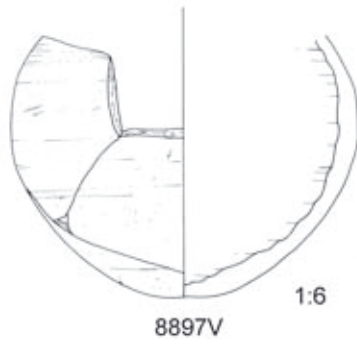
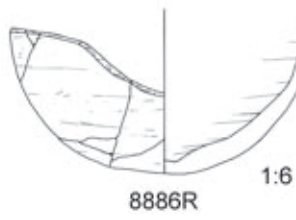
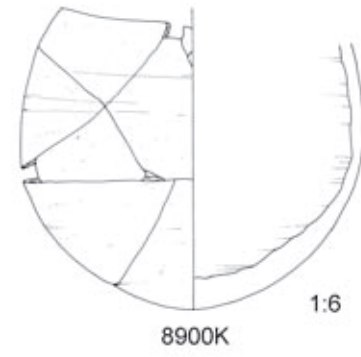
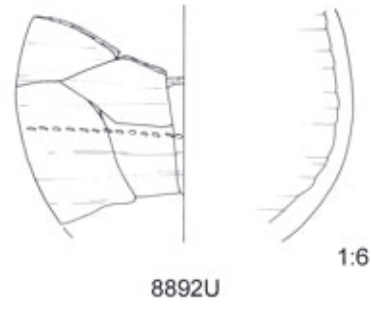
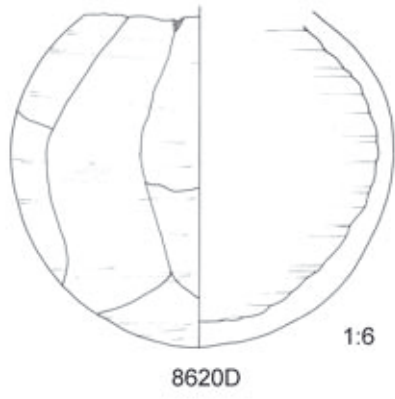

Abb. T58

Vasen/Flaschen, feine/mittlere/grobe Ware, Volumen (in Liter)

8892Y	lc2	j/61Gru.2	a (G-F)	9,6
8892V	lc2	j/61Gru.2	a (G-F)	18,16
8900P	lc1	L232	d	1,6
8898B	lb2	L540	c	1,75
8897T	lc1	L107	b (-c)	2,32
8899H	lc1	L103	b/c	2,42
8897M	lc2	L105	b/c	11
8897U	lc2	L105	b/c	12,7
8618O	lc2	o/59Gru9	b/c-c	14
8898V	lb2	k/58M130	e/1	0,5
8643O	lc1	o/59; Gru.18	e/1	4,5
8886E	lc2	L528	e/1	6,4
8886G	lc2	L531	e/1	6,8
L321	lc2	L321	e/1	7
8892W	lc2	L647	e/1	7
8897V	lc1	L504	e/1	8,3
8906Y	lc1	L5	e/1-2	8,5
8897S	lc1	L590	e/1	8,9
8569C	lc1	L585	e/1	9,1
8617K	lb1	L527	e/2	0,86
8617P	lb2	L247	e/2	1
8892N	lc1	L247	e/2	2
8617O	lb2	L245	e/2	2,16
8617N	lc1	L245	e/2	2,2
L270	lc2	L270	e/2	2,8
L245	lc2	L245	e/2	5,6
L217	lc2	L217	e/2	7
8569I	lc1	L16	e/2	7,3
8897L	lc1	L339	e/2	7,62
8900K	lc1	L579	e/2	9,3
8892S	lc1	L247	e/2	9,5
8892U	lc1	L569	e/2	9,6
8620D	lc2	L16	e/2	11,5
8886S	lc2	L16	e/2	19,3
8888T	lc1	L172	e/2-3	1,35
L273	lc1	L273	e/2-3	1,6
8620F	lc2	o/59Gru22	e/2-3	7
8892X	lc2	L273	e/2-3	11,24
8886C	lc1	L380	e/3	2
8906V	lc1	L307	e/3	2,45
8892O	lc1	L284	e/3	3,24
8898L	lc1	L621	e/3	3,47
8886D	lc2	n/58Gru.16	e/3	8,6
8897Q	lc2	L17	e/3	8,88
L551	lc2	L551	e/3	9,4
8897X	lc1	L306	e/3	14,5
n/60Gru.10	lc1	n/60Gru.10	e/3-4	1,5
8617L	lc2	L54	e/3-4	2
8898U	lb2	L579	e/3-e/4	2,8
8898G	lc2	L548	e/3-4	7
8892T	lc1	L548	e/3-4	9,7
8898A	lb2	L547	e/4	2,28
8886F	lc2	n/58Gru.19	e/4	6,25
8608A	lc2	l/61Gru32	e/4-f	6,8
8898X	lc2	l/61Gru.31	e/4-f	7
8897O	lc2	l/61Gru.22	e/4	11

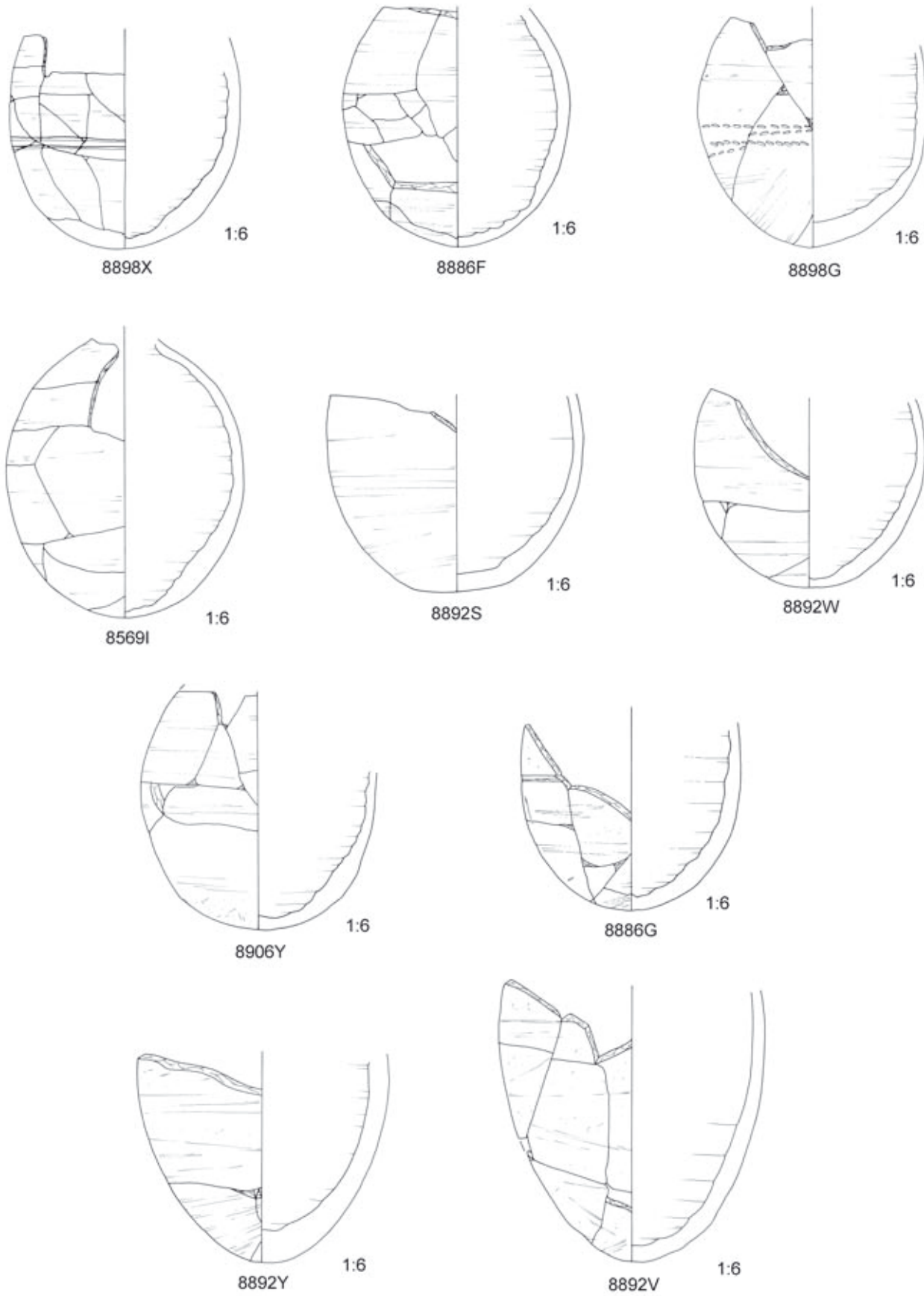

Abb. T58a/b Flaschen/Vasen: Volumen



Die „Flaschen/Vasen mit einfachem Rand“ eingefügt in das Diagramm nach ARNOLD, *Pyramid Senwosret I*, Fig. 76

Abb. T59 Flaschen/Vasen mit einfachem Rand: Aperture Index

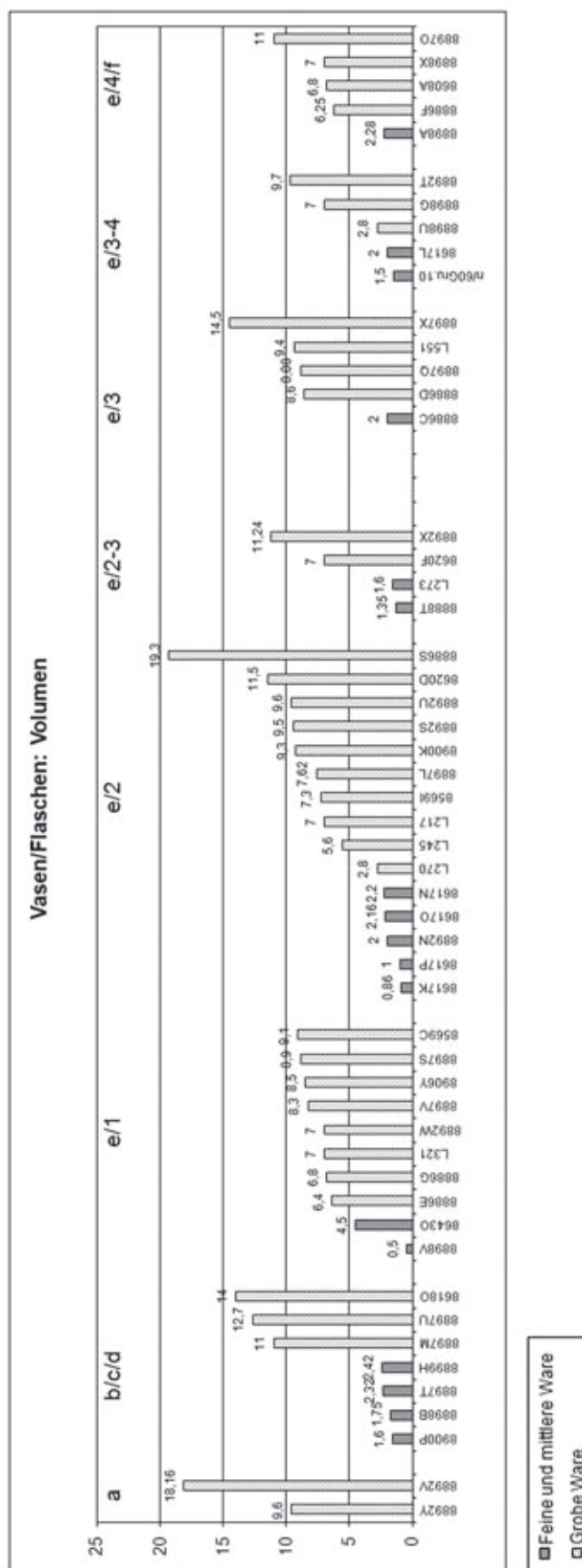
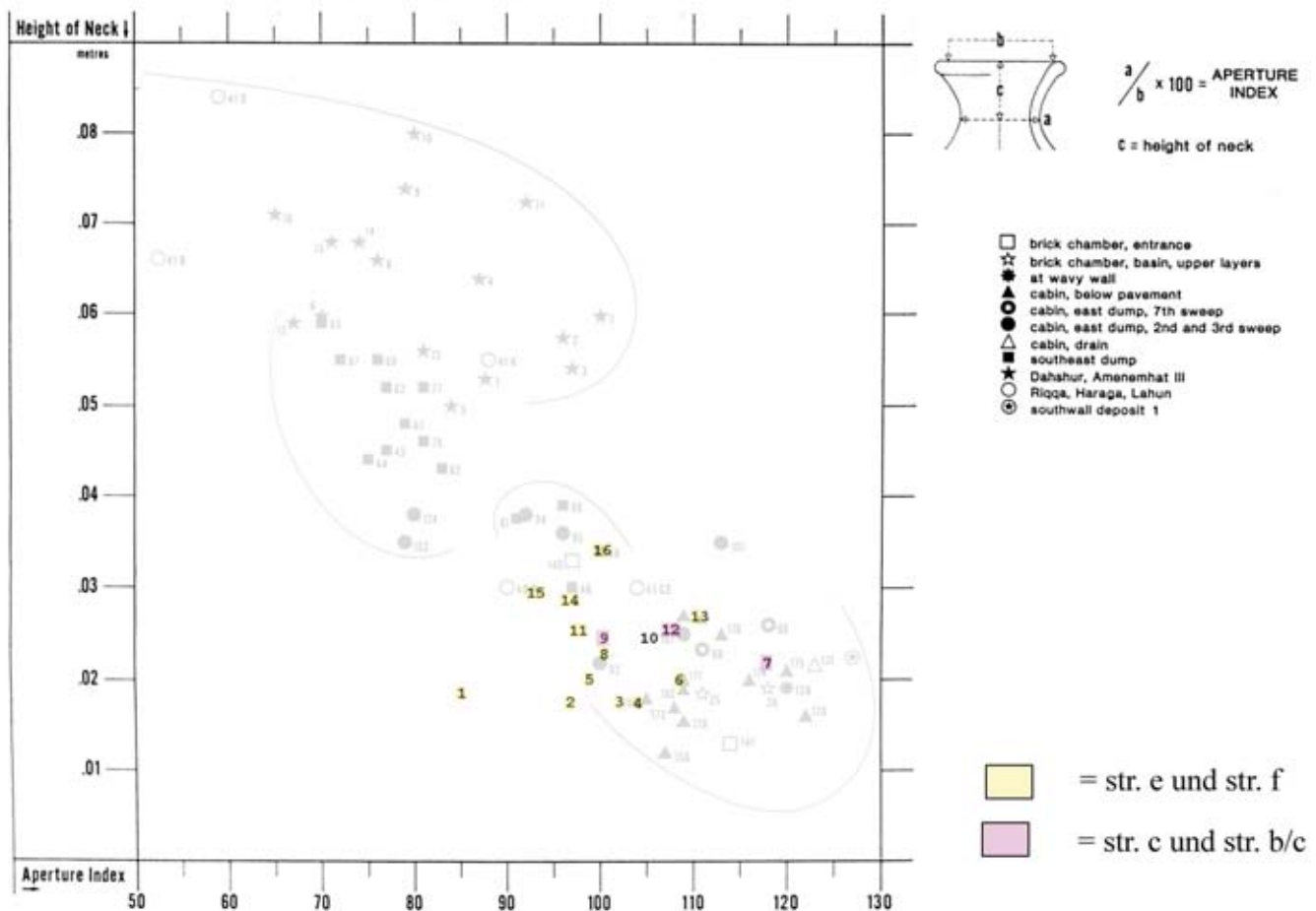
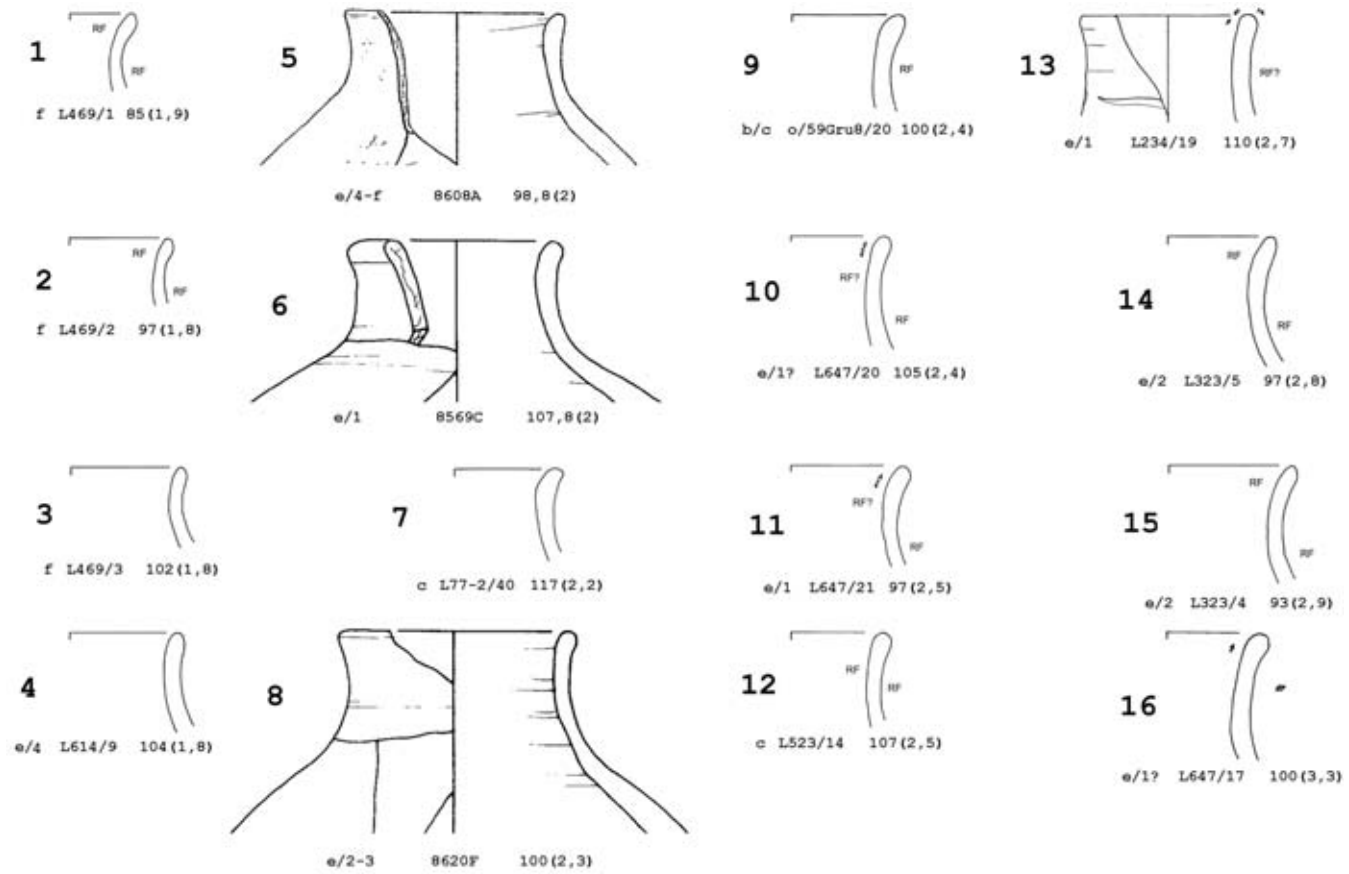

Abb. T60



Die „Flaschen mit Wulstrand“ eingefügt in das Diagramm nach Do. ARNOLD, *Pyramid Senwosret I*, Fig. 76

Abb. T61 Flaschen mit Wulstrand: Aperture Index

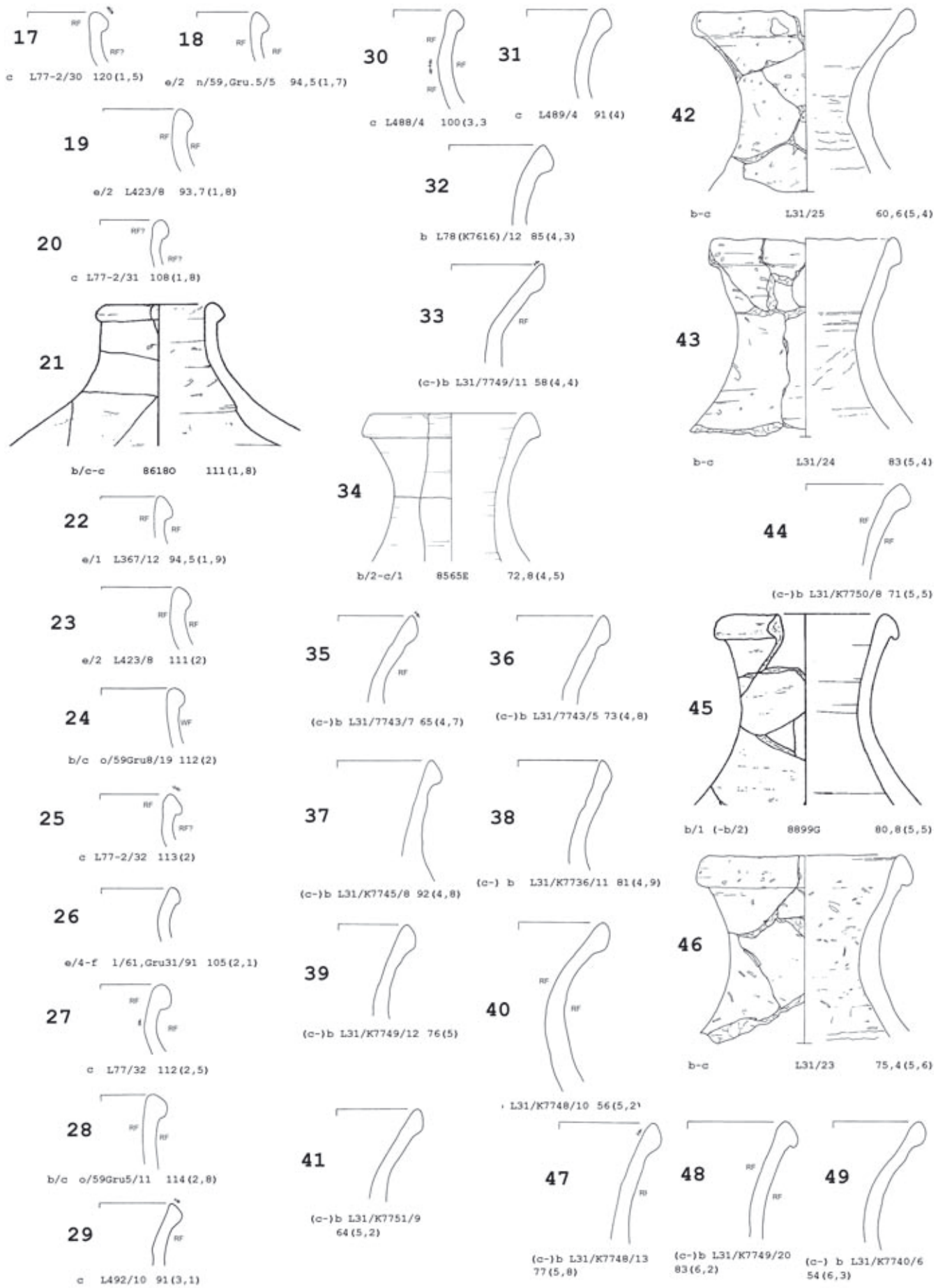
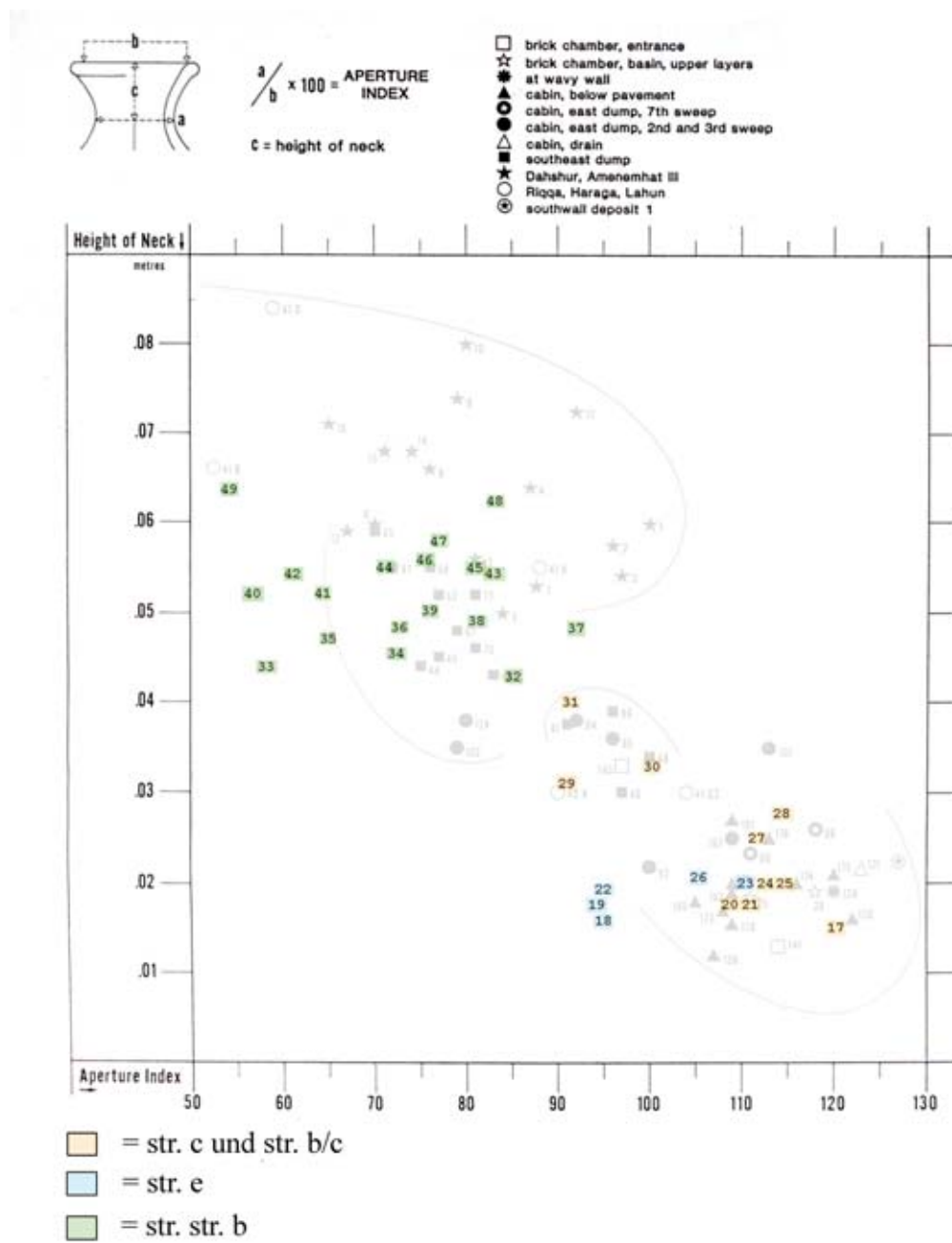
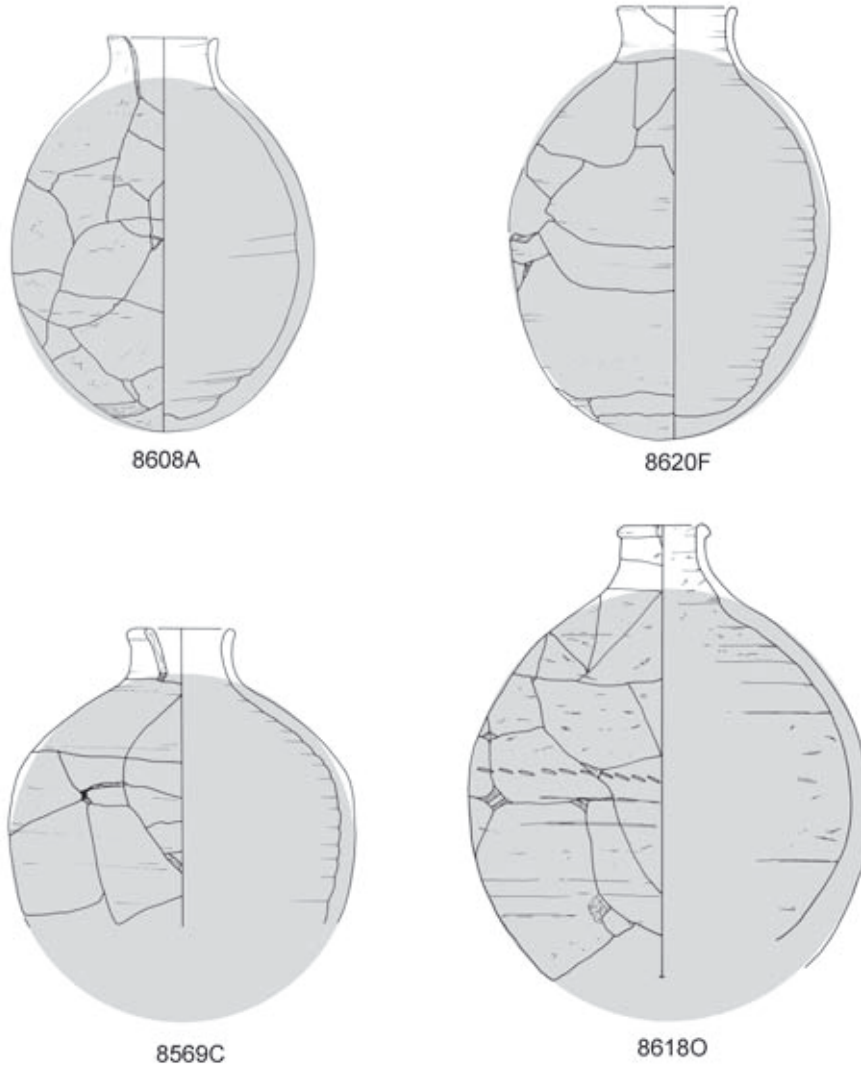

Vasen/Flaschen mit elliptischer Körperkontur

Gießgefäß mit eingezogenem abgestrichenen Rand (49)



Abb. T62

Miniaturgefäße/Modelle (50)



Abb. T63

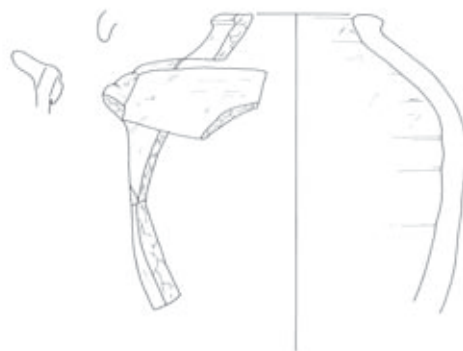

Vasen aus poliertem Mergelton Ila2 (Marl A2) (51)

**einfach**

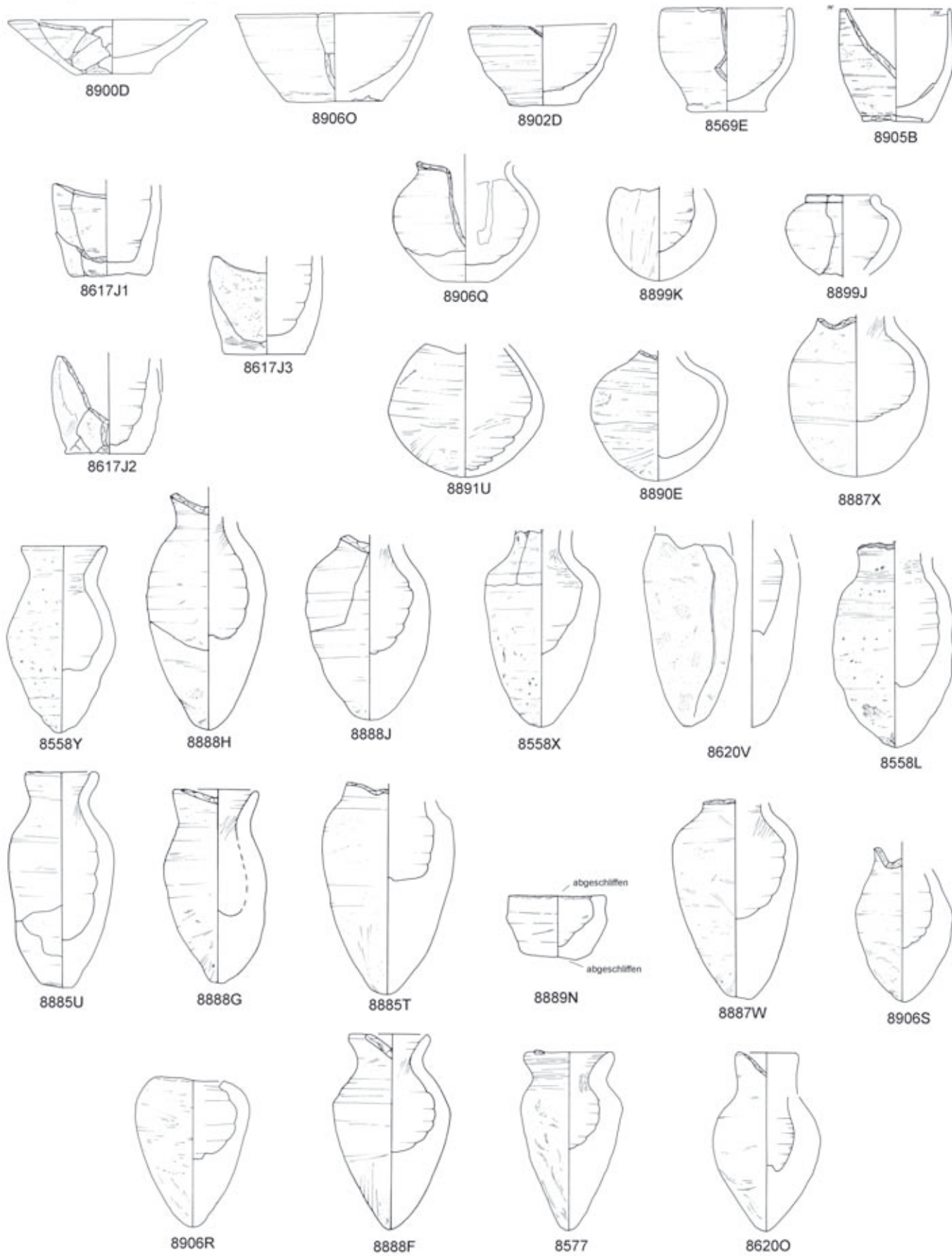
**Lippe**

e/4



e/3

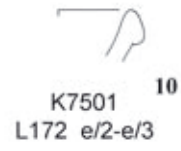

e/2

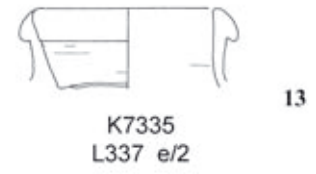
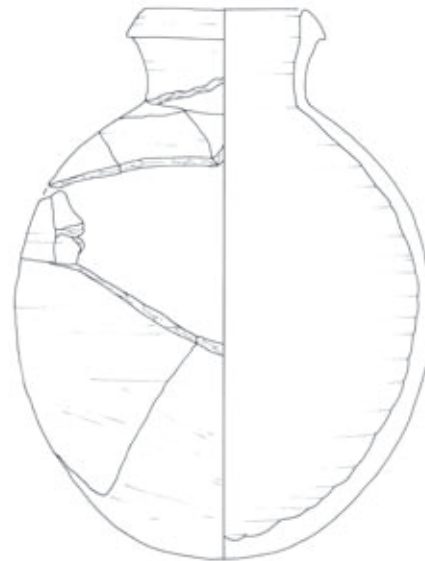

e/1



c



Abb. T64

Vasen aus poliertem Mergelton IIa2 (Marl A2) (51)

gekehlt

Tellerrand

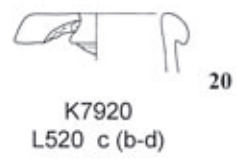
e/4

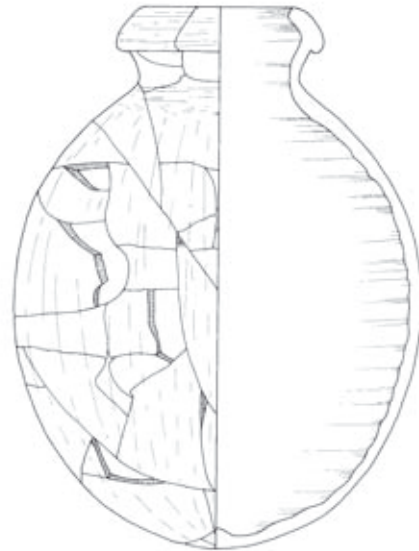

e/3

8617  
L380 e/3



K7710  
L291 e/3 27

e/2



K7490  
L165 e/2

23



K7490  
L165 e/2

22



K7411  
L266 e/2

2

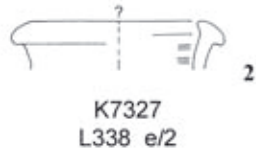

K7327  
L338 e/2

2



K7596  
L422 e/2

12



K8416  
L446 e/1-e/2 ?

7

e/1



K7580  
L361 e/1



K7579  
L364 e/1

27



K8369  
L590 e/1

51



K7860  
L35 c

c



K7561  
o/59-M str. c/b-c

9

Abb. T65



8617  
L380 e/3



K7660 (L352, e/4)



K8319 (L614, e/4)



K8136 (Mauern str. c)

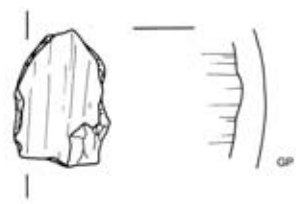

8559U (L520 d/c/b)



Ila2 ?

Abb. T66 Ila2 polierte Vasen und GP/RP Vergleichsstücke (Scherben)



K7492, Wd.-poliert. Ila2

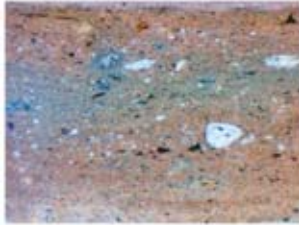

K7948, Wd SP, Ila2 ?

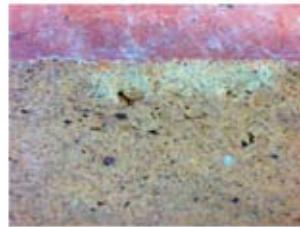
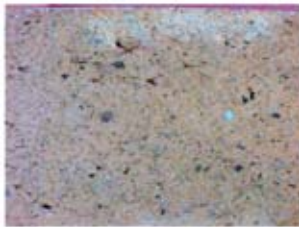

K7860, Wd PR, Ila2 ?



K7579, Wd RP, Ila2 ?

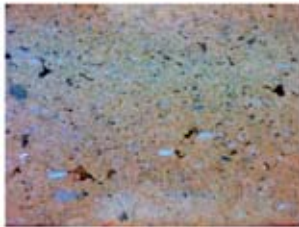

K7576, Wd. RP, Ila2 ?

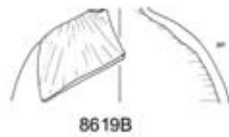

8619B, Wd. BP, Ila2 ?



Ila2.

Abb. T67 „Ila“-poliert, petrographisch untersucht (“Nile sediment“)

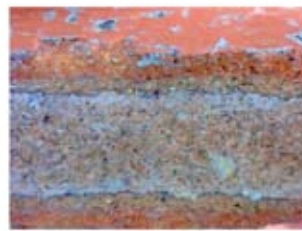
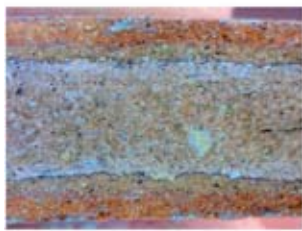

K7446  
Wd RP. Ila2 ?



K8335  
Ila3



K7474  
Wd RP. Ila2 ?



K7815  
Ila3 ?



K7675  
Wd RP. Ila2 ?



K7757  
Ila3 ?

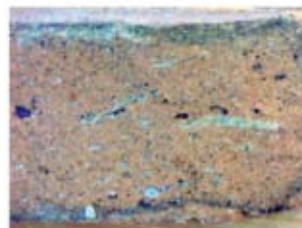

K7771  
Wd RP. Ila2 ?

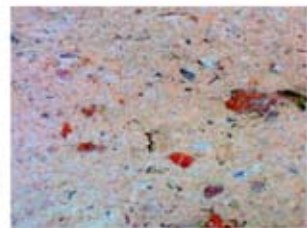

K8316  
Ila4 ?

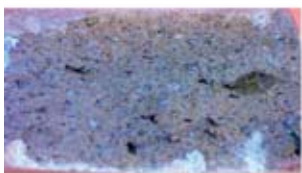

K7497  
Wd GP. Ila2 ?

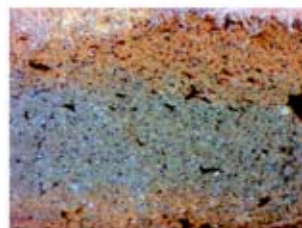

K8264  
Wd GP. Ila2 ?



K7684  
Ila3 ?

8905F  
Ila3



Abb. T68 Ila2-poliert, Ila3, Ila4

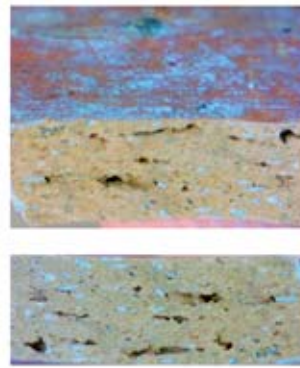
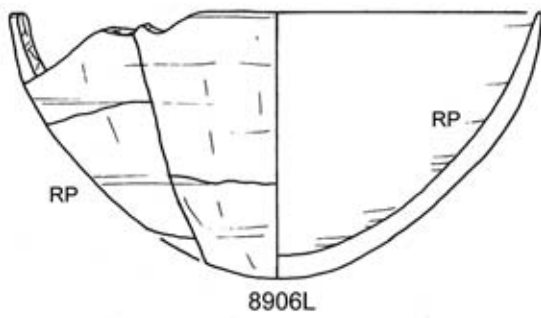

IIa2 ?

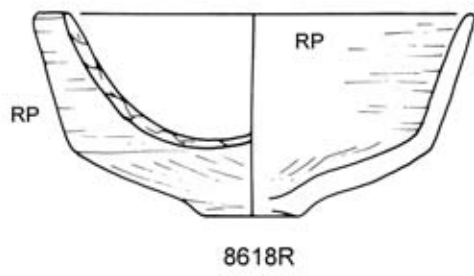

IIa2 ?

Abb. T69

Keramik aus Mergelton IIa3/IIa4 (53)

Vasen



Abb. T70

Wandscherben mit Ritzdekoration



undekorierten Wandscherben mit Reibekanten (Auswahl)

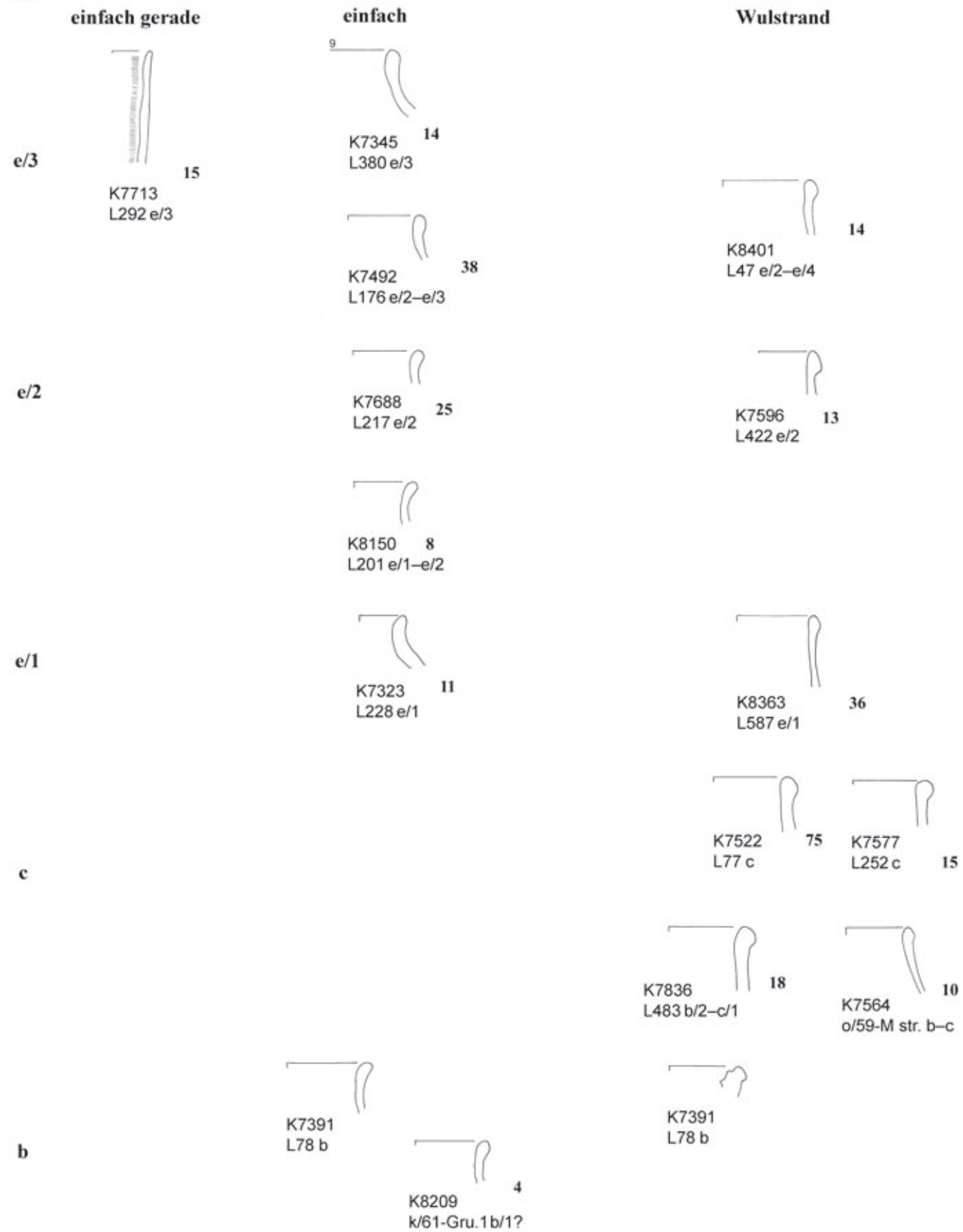
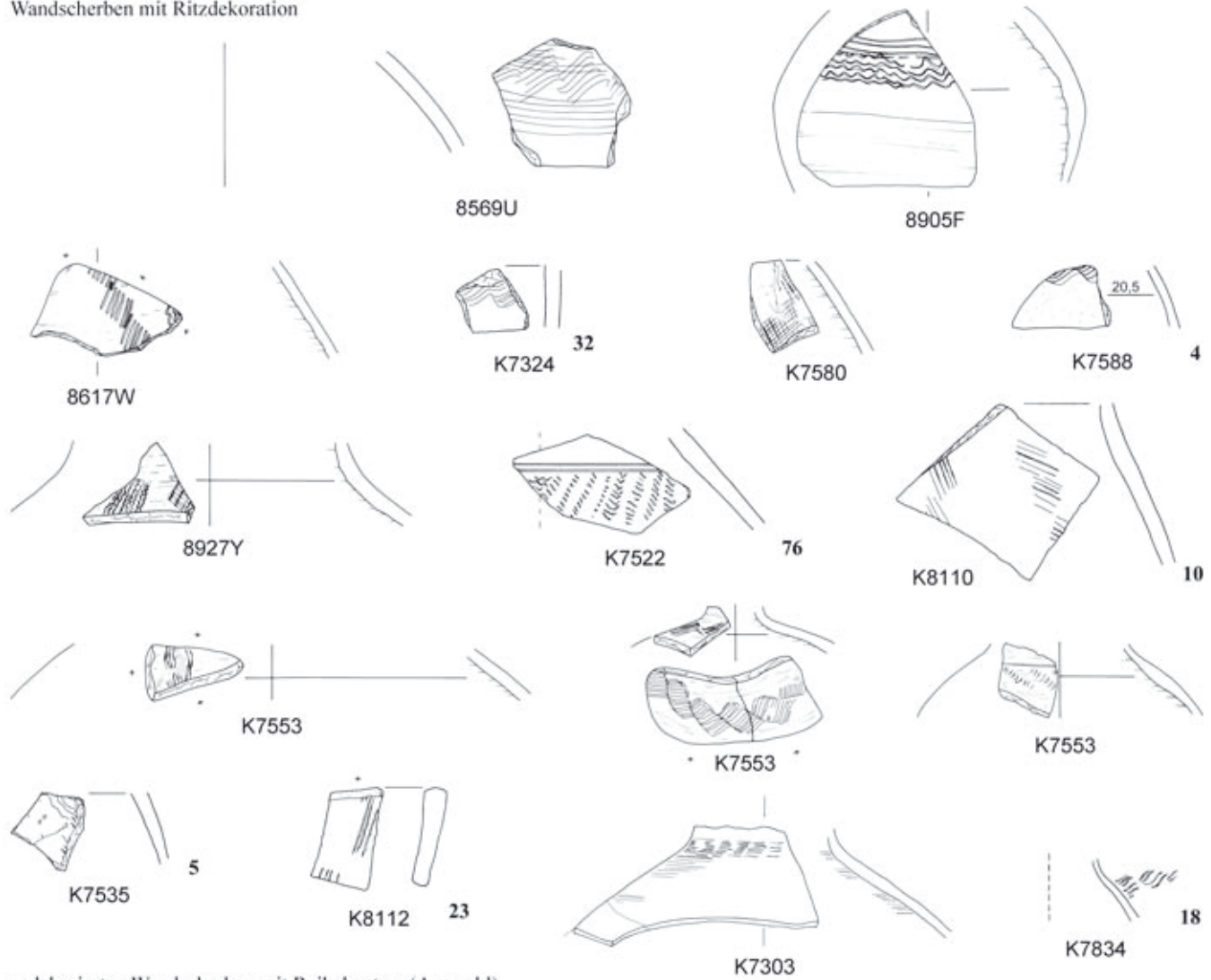

Abb. T71



Halbkugelige einfache Schalen (54)

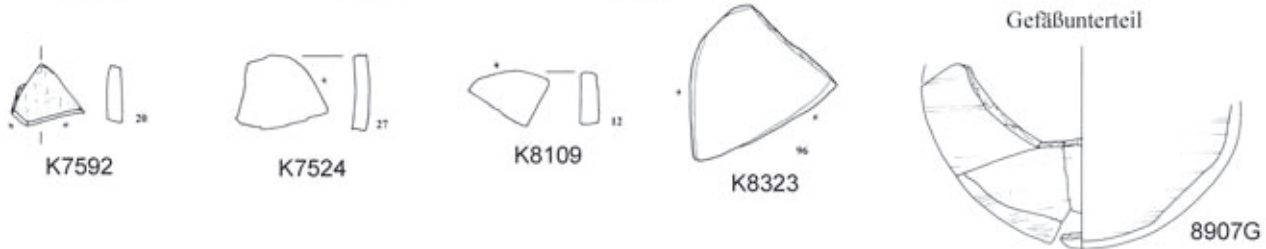
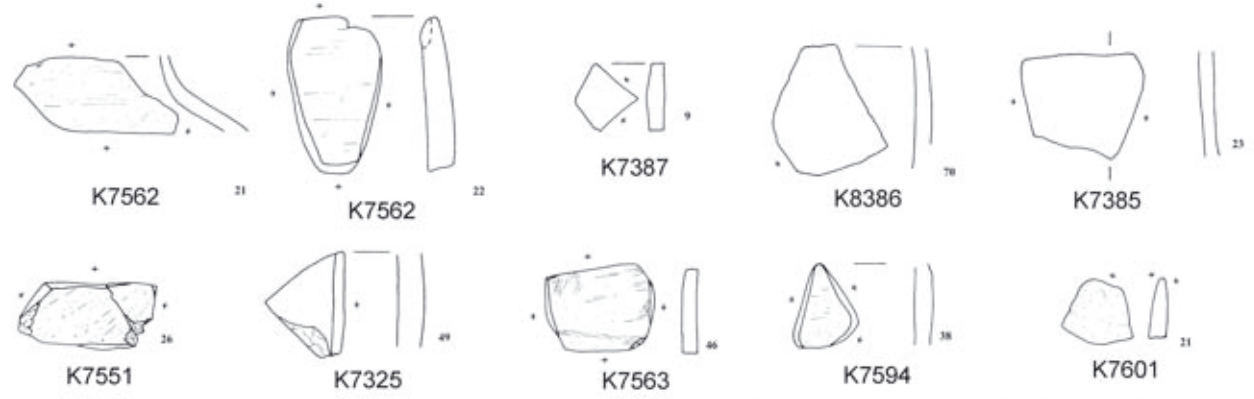

Tiefe Schalen mit eingezogenem Rand (55)

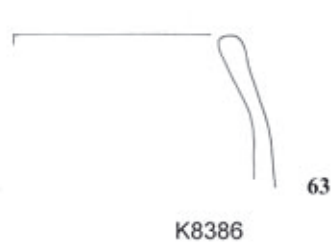

Schalen mit nach innen eingeschlagenem Rand (56)

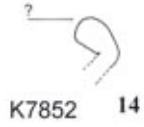

Schalen mit nach innen eingeschlagenem Rand mit Tülle (56a)



Fußschalen (57)



Abb. T72

Kielschüsseln (58)



Schüsseln mit Handhabe (59)

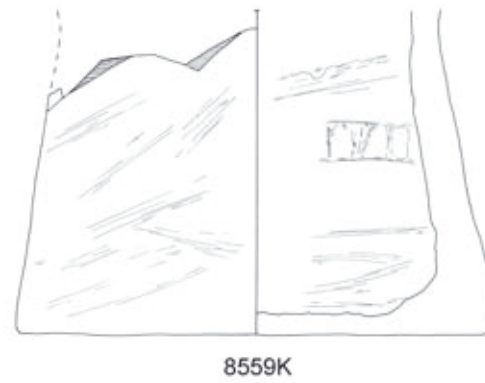
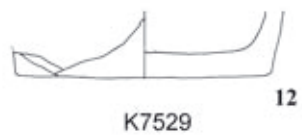
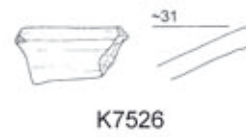
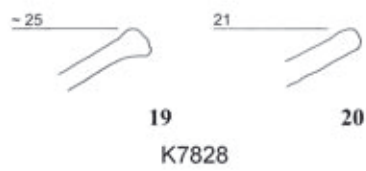
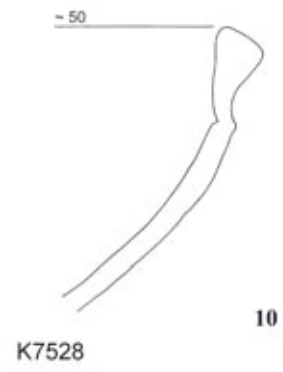
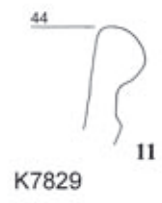
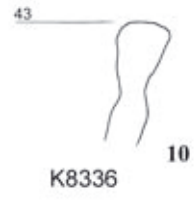

Abb. T73

Töpfe 1 (60)

a) Kleine Töpfe mit kurzem nach außen gerichtetem Rand

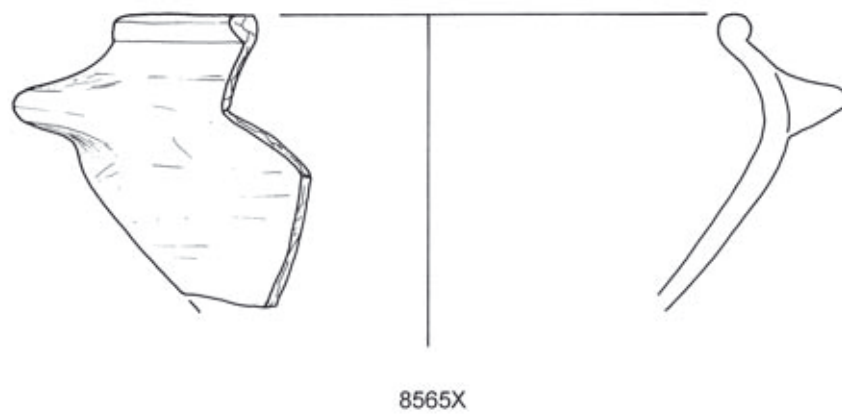
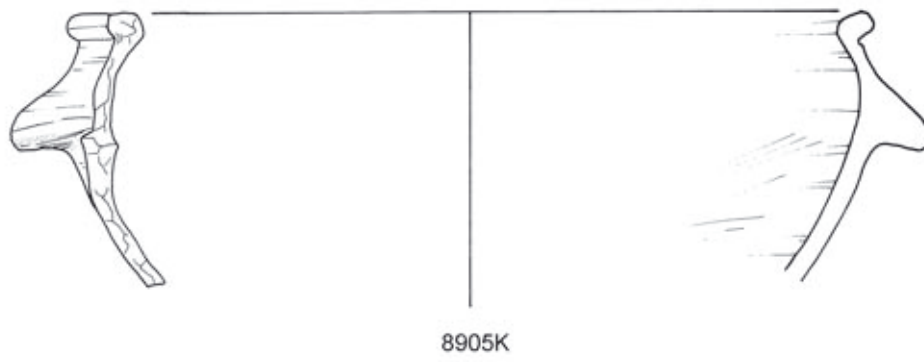
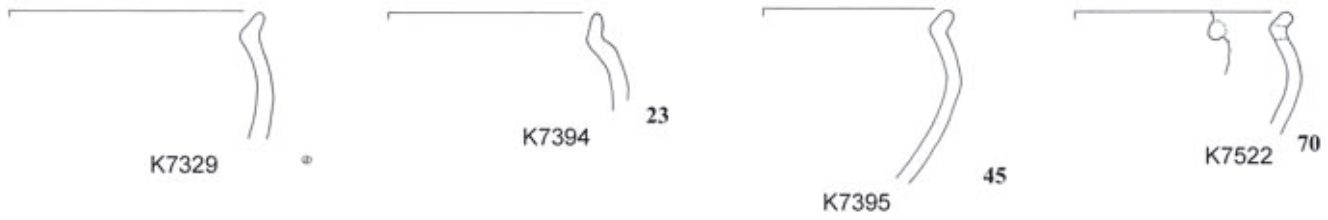

b) Kleine Töpfe ohne Schulter mit nach außen gerichtetem Rand



c) Kleine Töpfe mit nach außen umgeschlagenem Rand

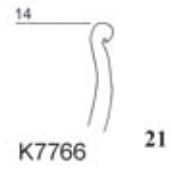

d) Töpfe mit nach außen gerichtetem Rand

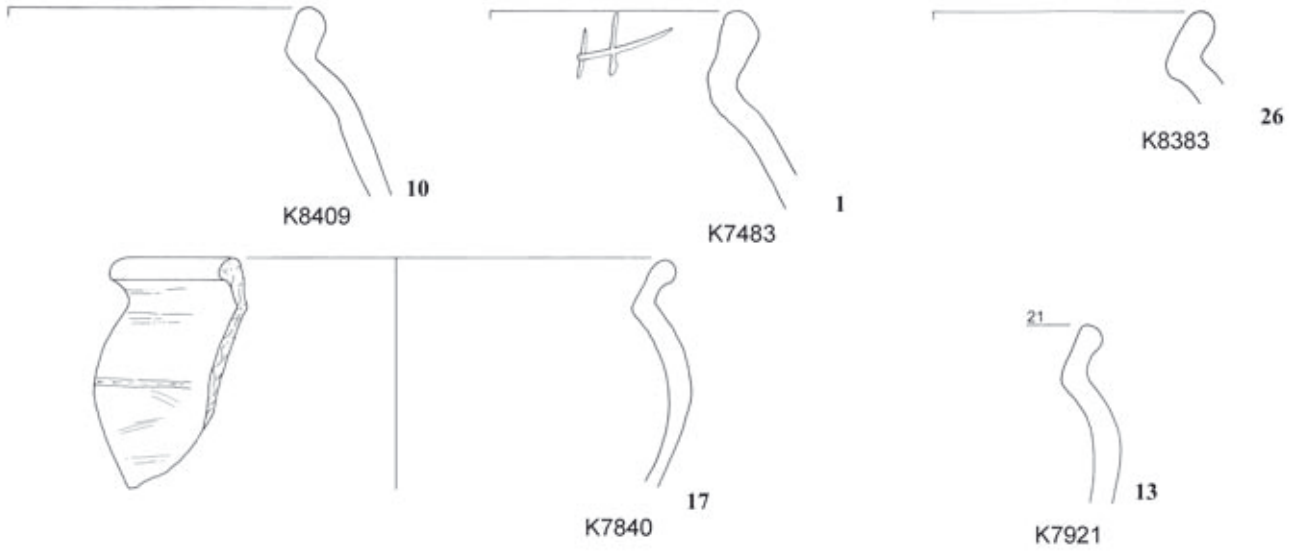

e) Töpfe mit nach außen gerichtetem Rand, innen gekehlt



Abb. T74

## f) Ausgußtöpfe (ältere Gruppe)



## (jüngere Gruppe)

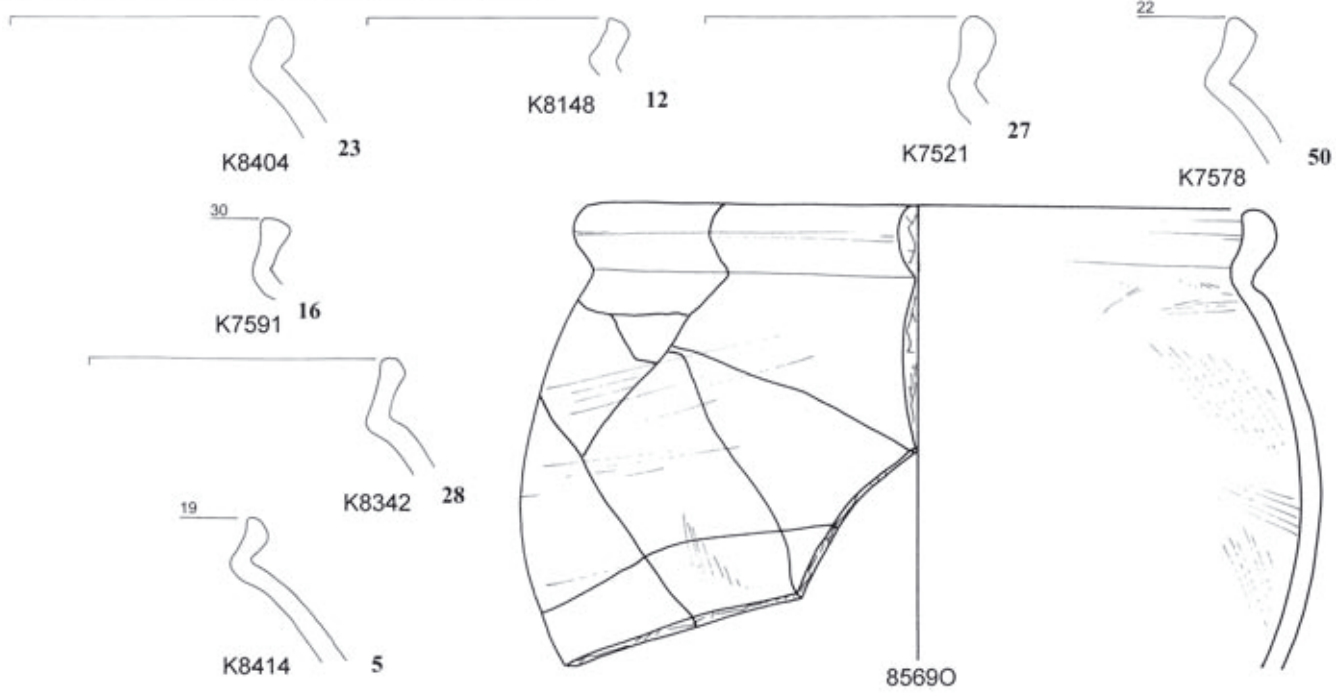
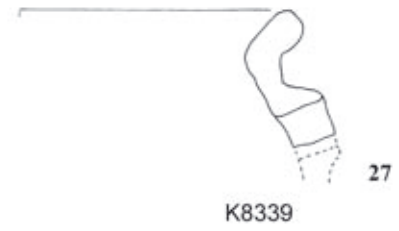
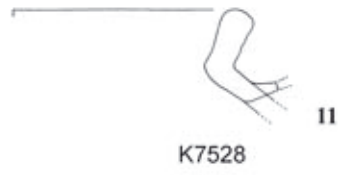
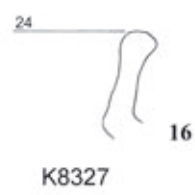

## g) Topf mit Randleiste



Abb. T75

Töpfe 2 (61)

a) Kleine kugelige Töpfe mit wulstigem Rand („Nw-Töpfe“)

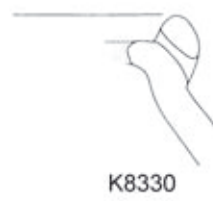
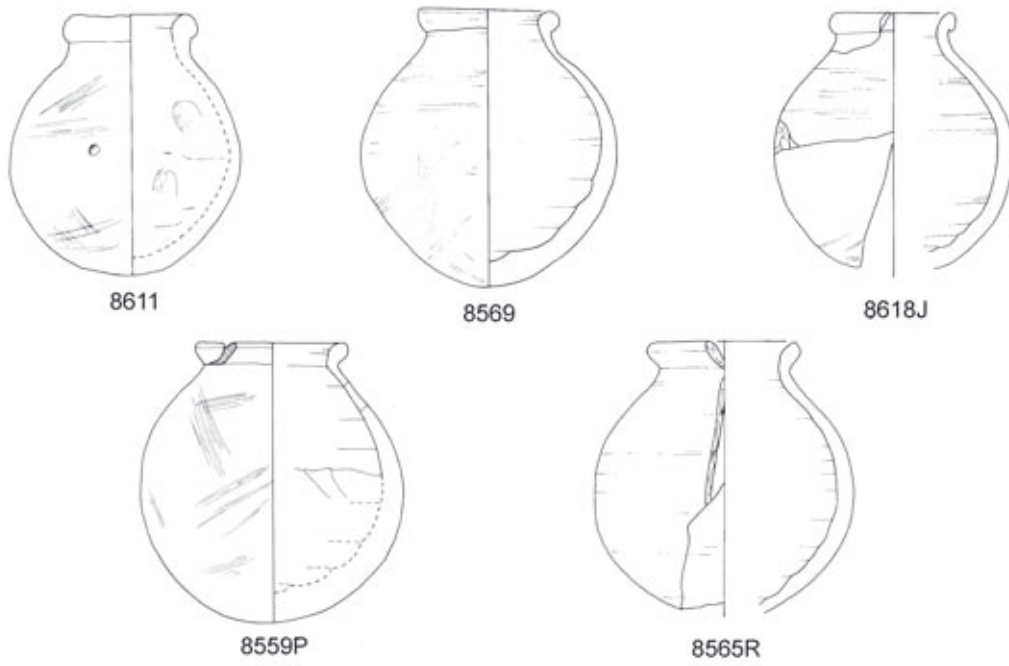

b) Mittlere Töpfe mit profiliertem Rand



Abb. T76



Abb. T77

e) Töpfe mit umgeschlagener Mündung

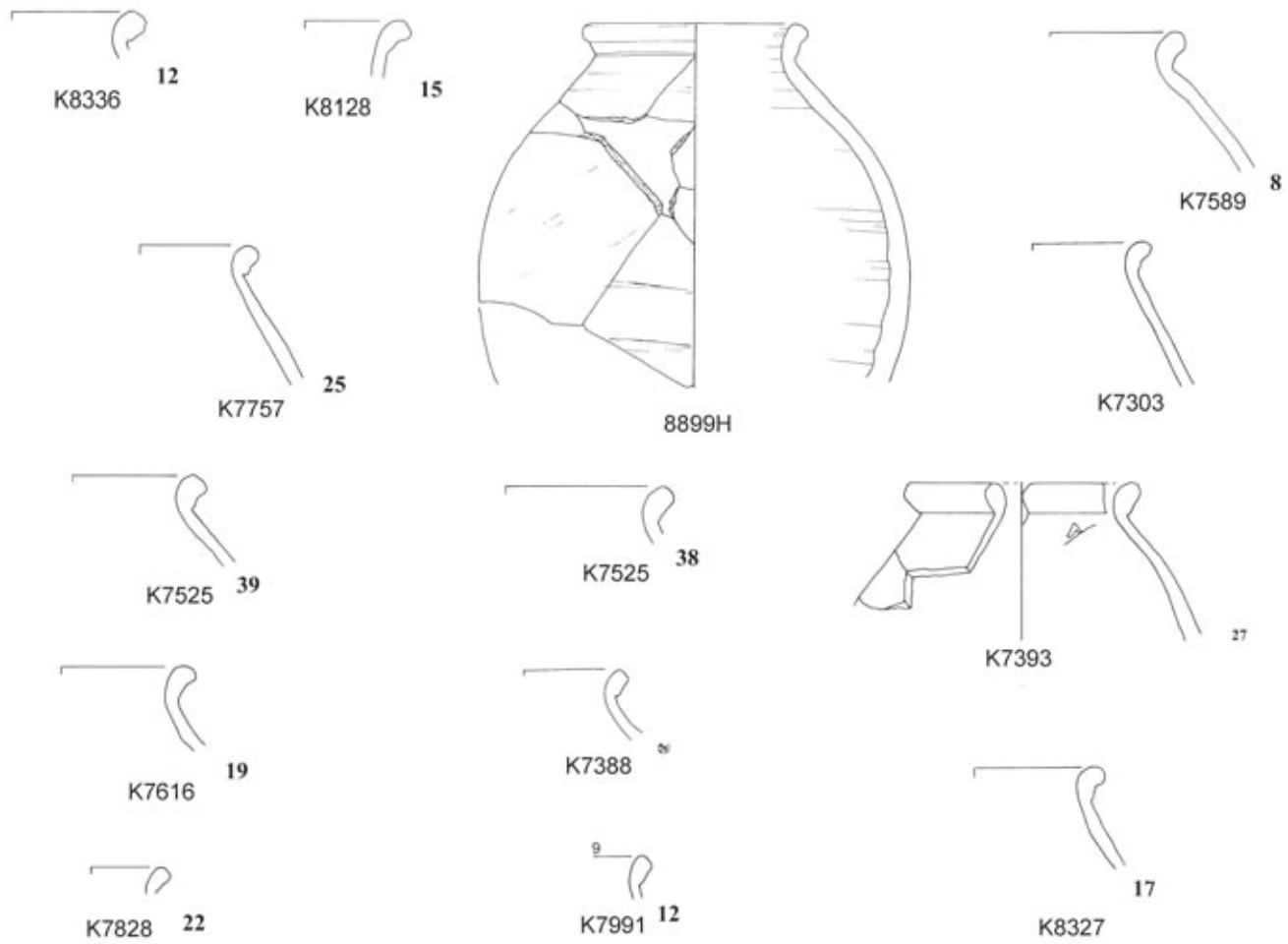

Abb. T78

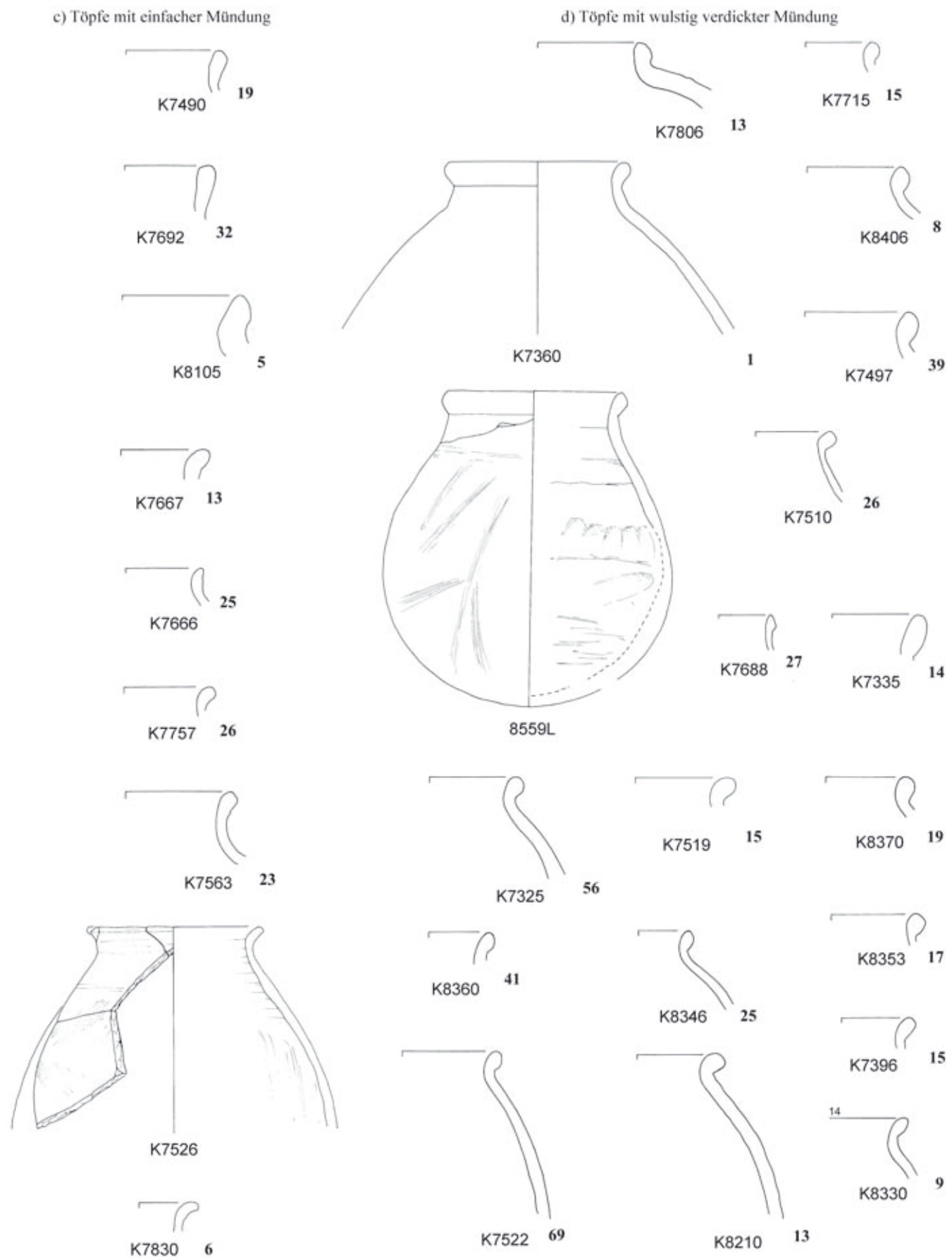
## f) Töpfe mit wulstig verdicktem Rand, innen profiliert



## g) Töpfe mit gelängt verdickten Mündungen

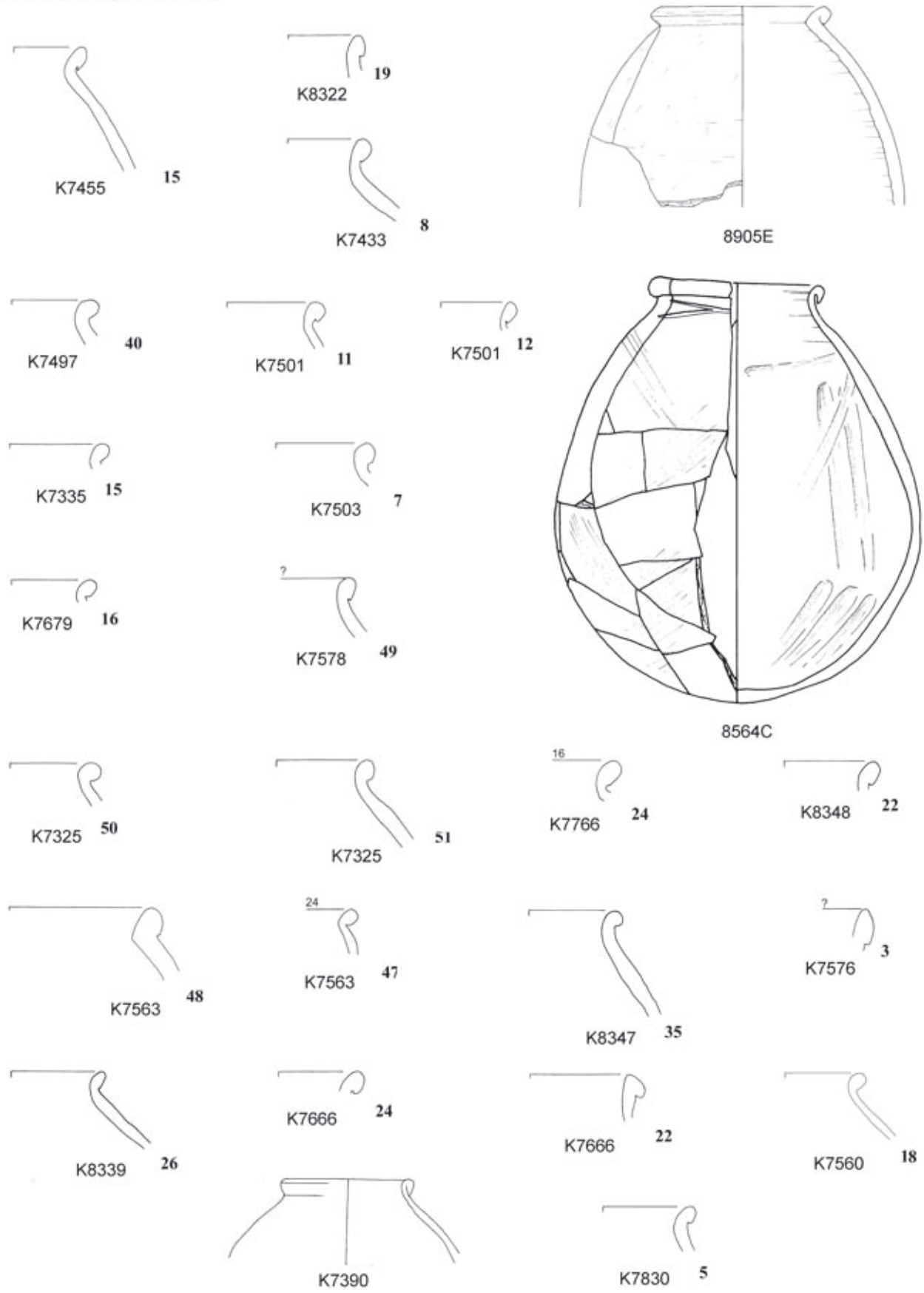
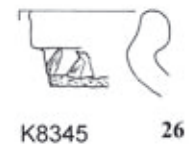
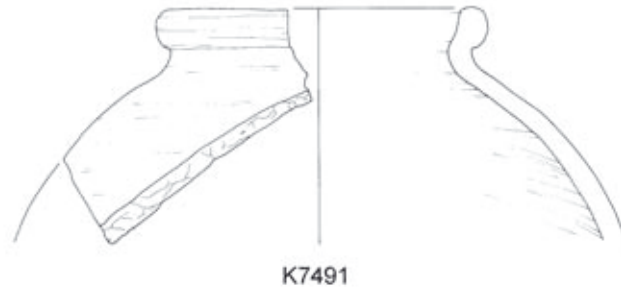
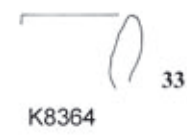
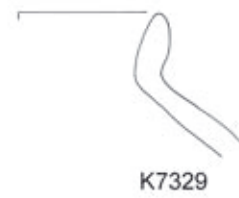
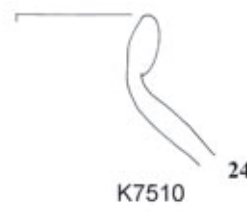
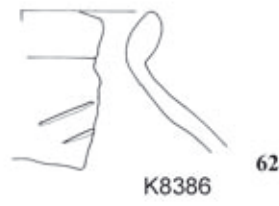

## h) Töpfe mit Außenlippe und Hals

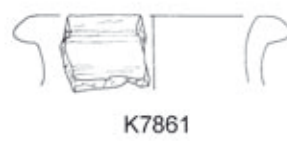
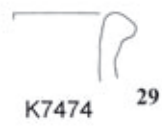

## i) Körper



Abb. T79



Vasen mit profilierter Mündung (62)

a) Frühformen



Abb. T80



Abb. T81

c) entsprechend BADER Typ 46= KOPETZKY, Typ 319/332/333

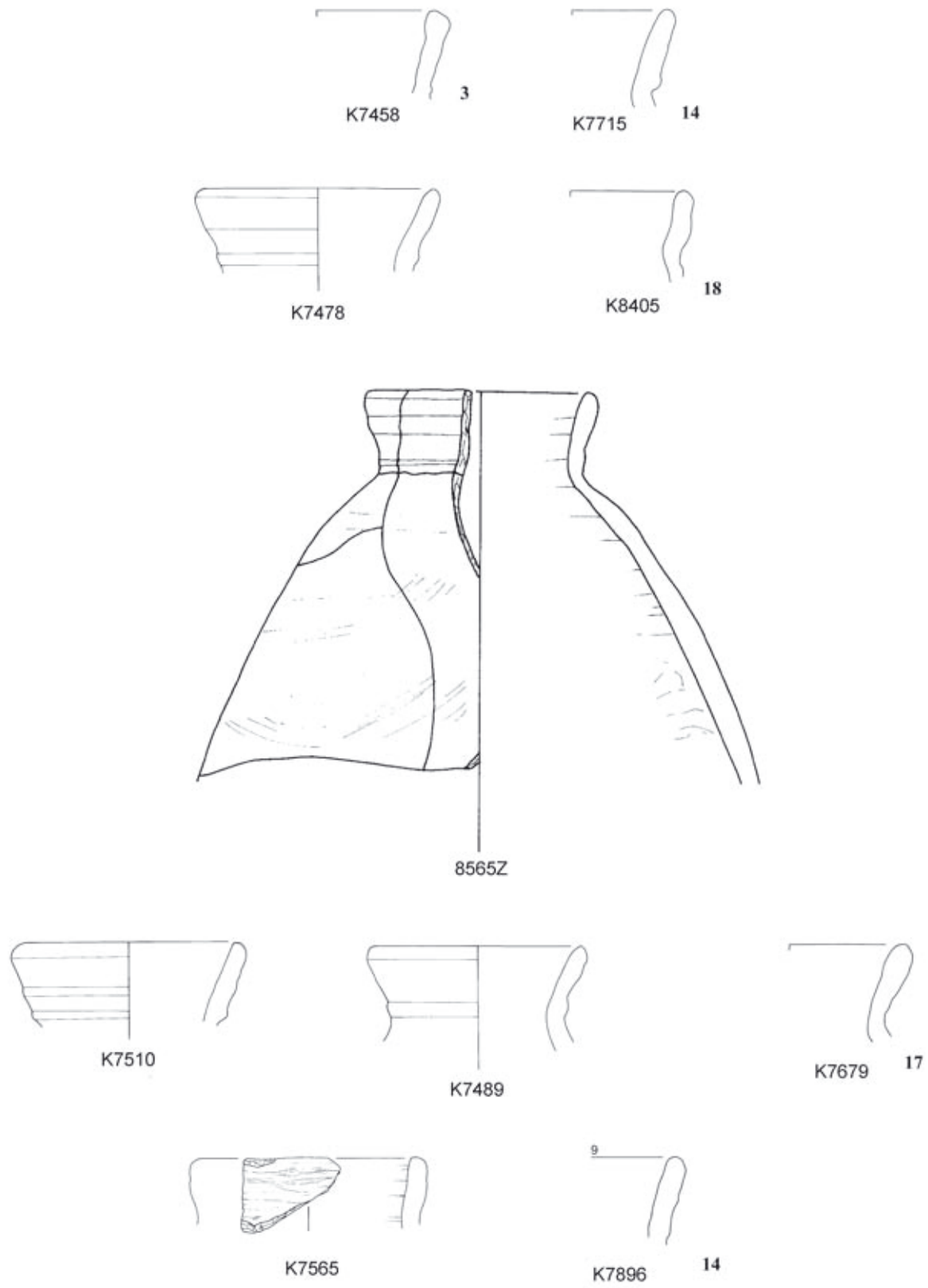

Abb. T82

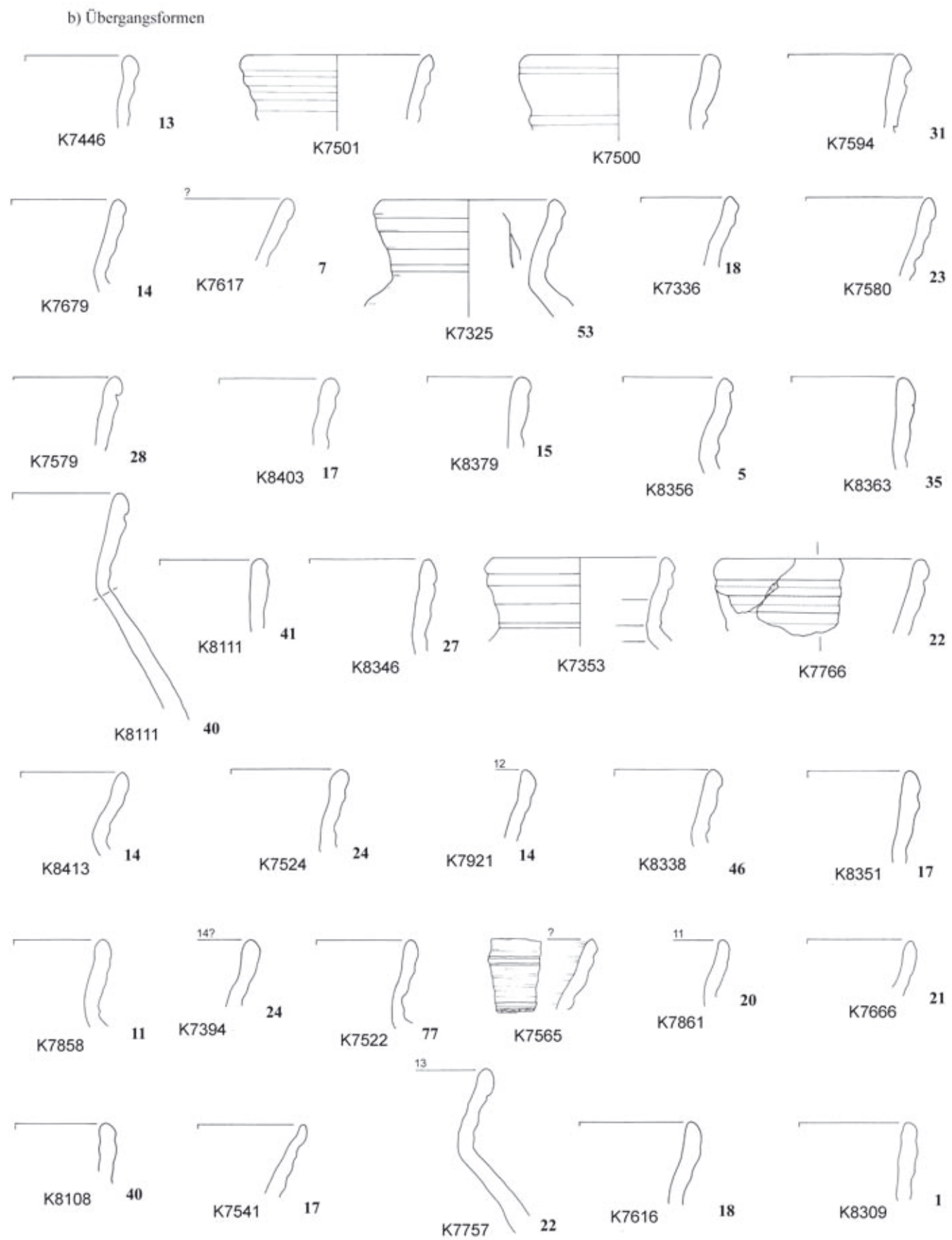
d) Große bauchige Vasen

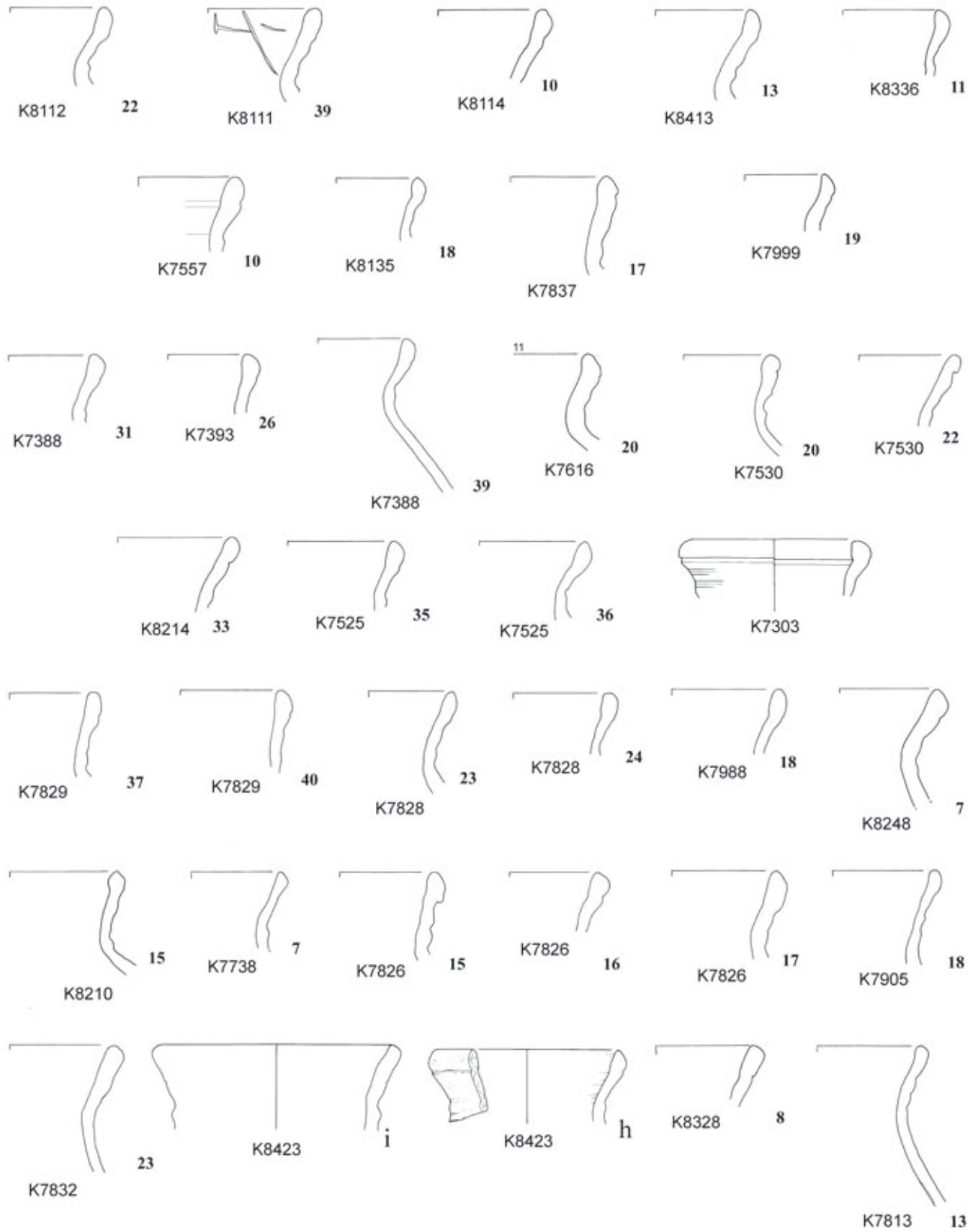
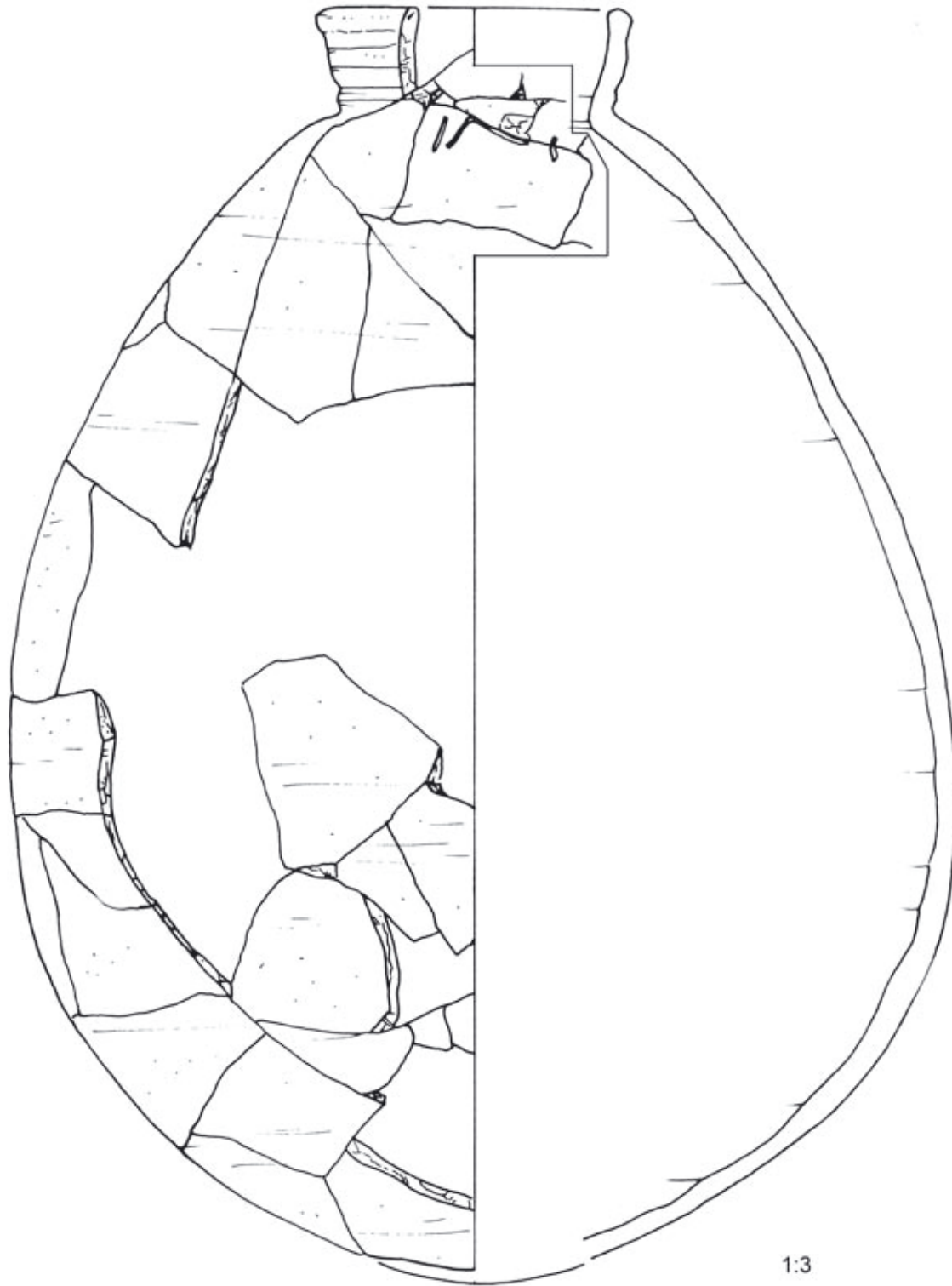

8559J

Abb. T83

Vasen mit innen profiliertem Rand (63)

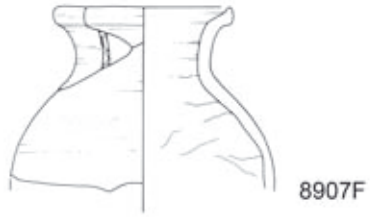

Vasen-Körper (64)

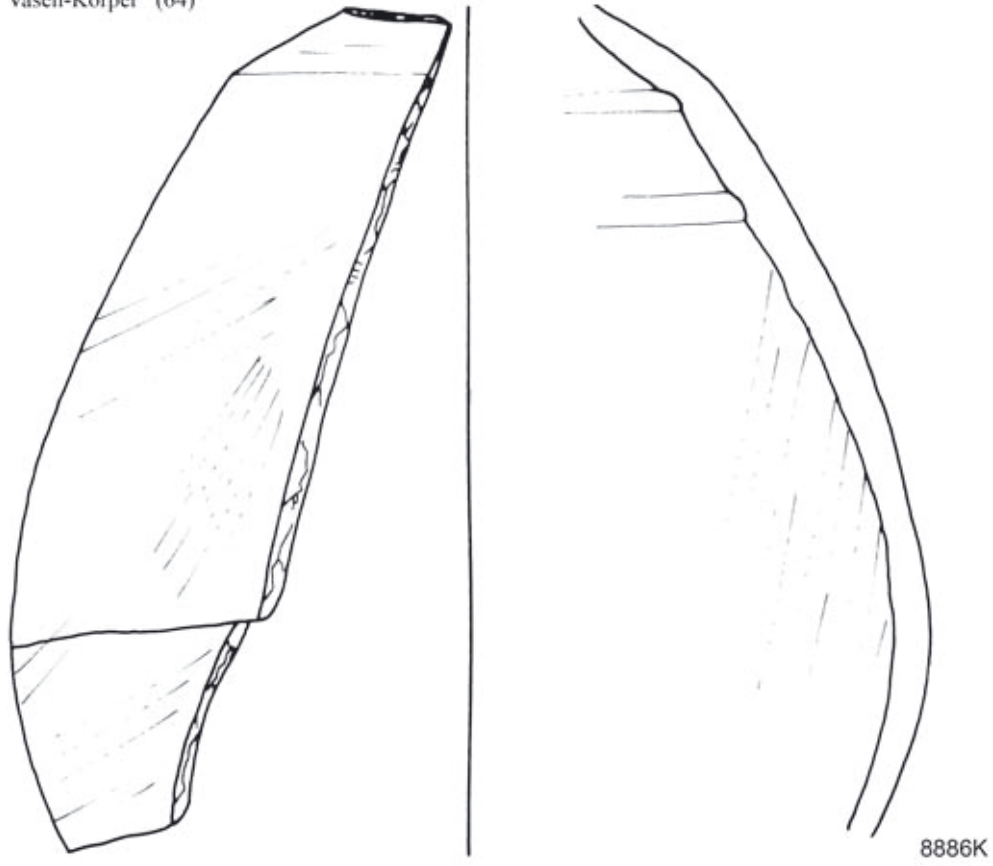

Henkelkrüge (65)



Abb. T84

Zire (Große Vorratsgefäße) (66)

Typ I

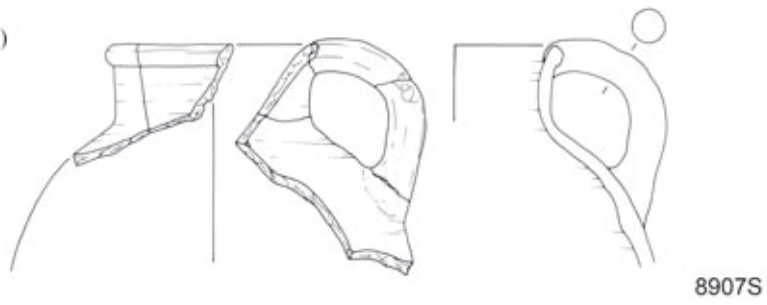

Abb. T85

Zire (Große Vorratsgefäße) (66) f.

Typ 1

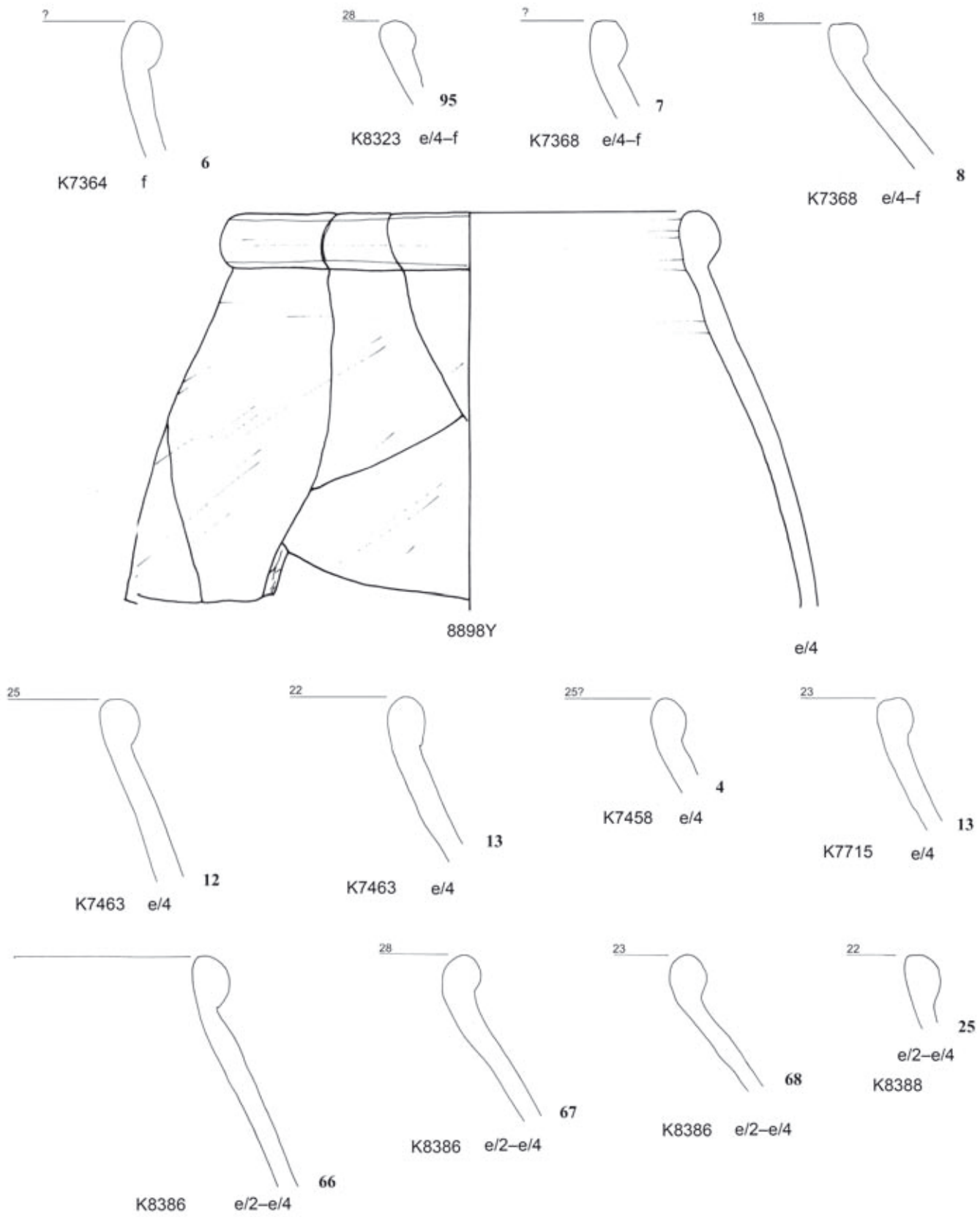

Abb. T86

Zire (Große Vorratsgefäße) (66) ff.

Typ 1

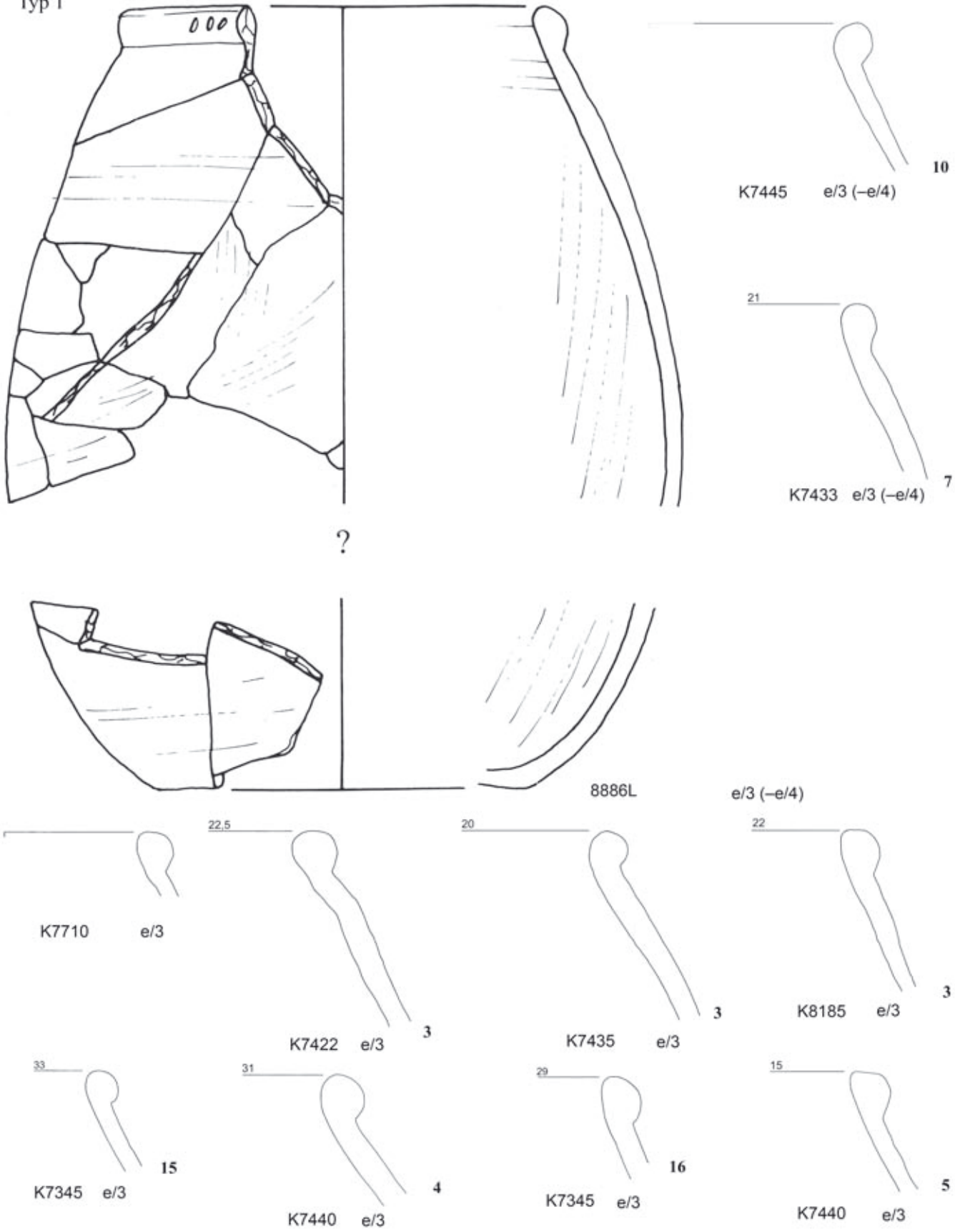

Abb. T87



Zire (Große Vorratsgefäße) (66) ff.

Typ 1

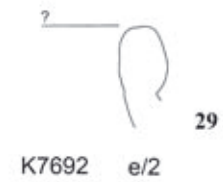
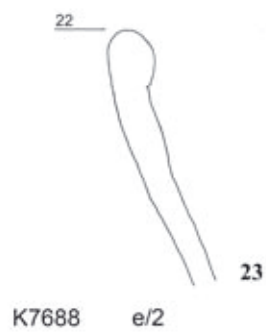
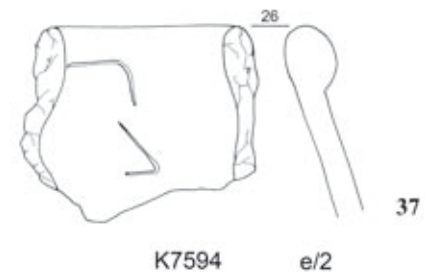
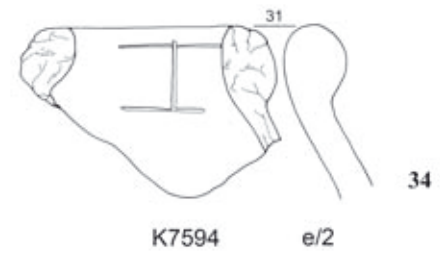
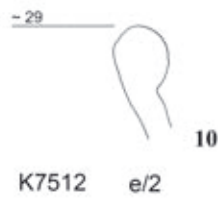
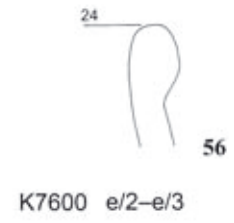
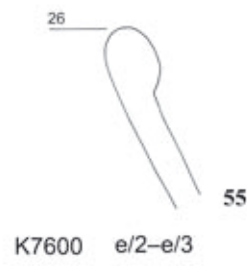
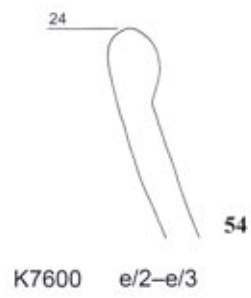
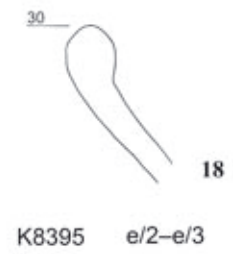
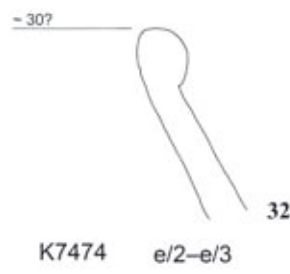
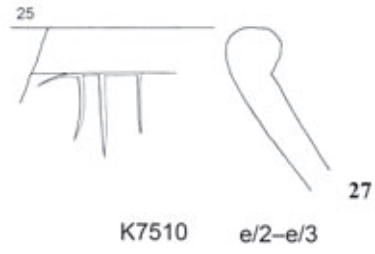
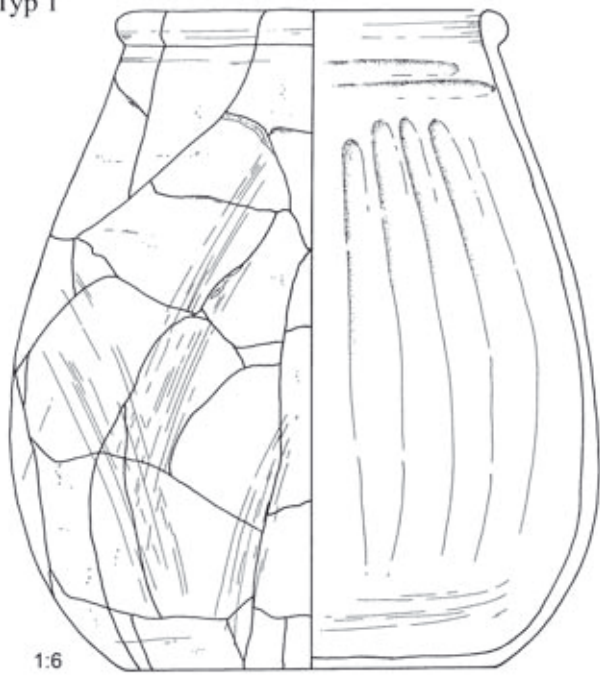

1:6

8559M

e/1-e/2

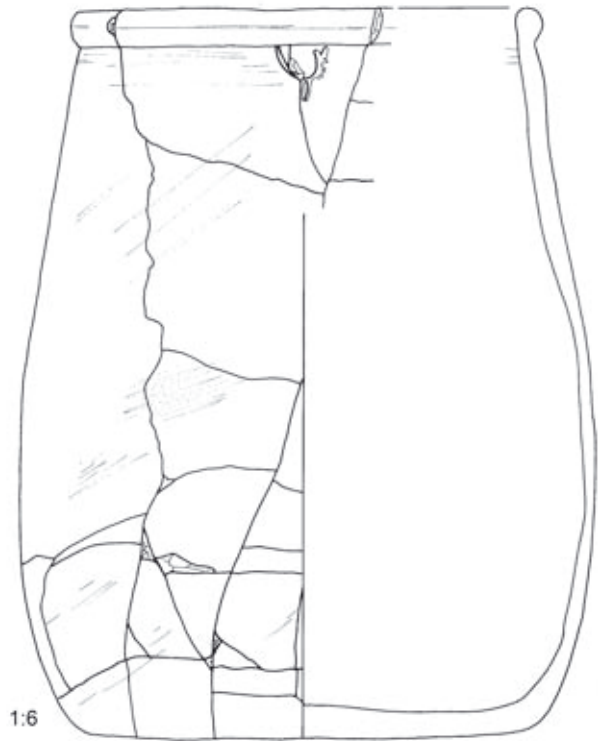

1:6

8619

e/1

28



11

K8148 e/1-e/2

22



17

K8163 e/1

28



17

K7336 e/1

22



9

K7323 e/1

21



3

K7323 e/1

26



3

K7588 e/1

30



16

K7519 e/1

K7323 e/1

28



16

K7325 e/1



33

K7324 e/1

25



36

K7599 e/1

K8384 e/1

K7324 e/1

31

K7325 e/1

K8403 e/1

16

Abb. T88

Zire (Große Vorratsgefäße) (66) ff.

Typ 1



Abb. T89

Zire (Große Vorratsgefäße) (66) ff.

Typ 2

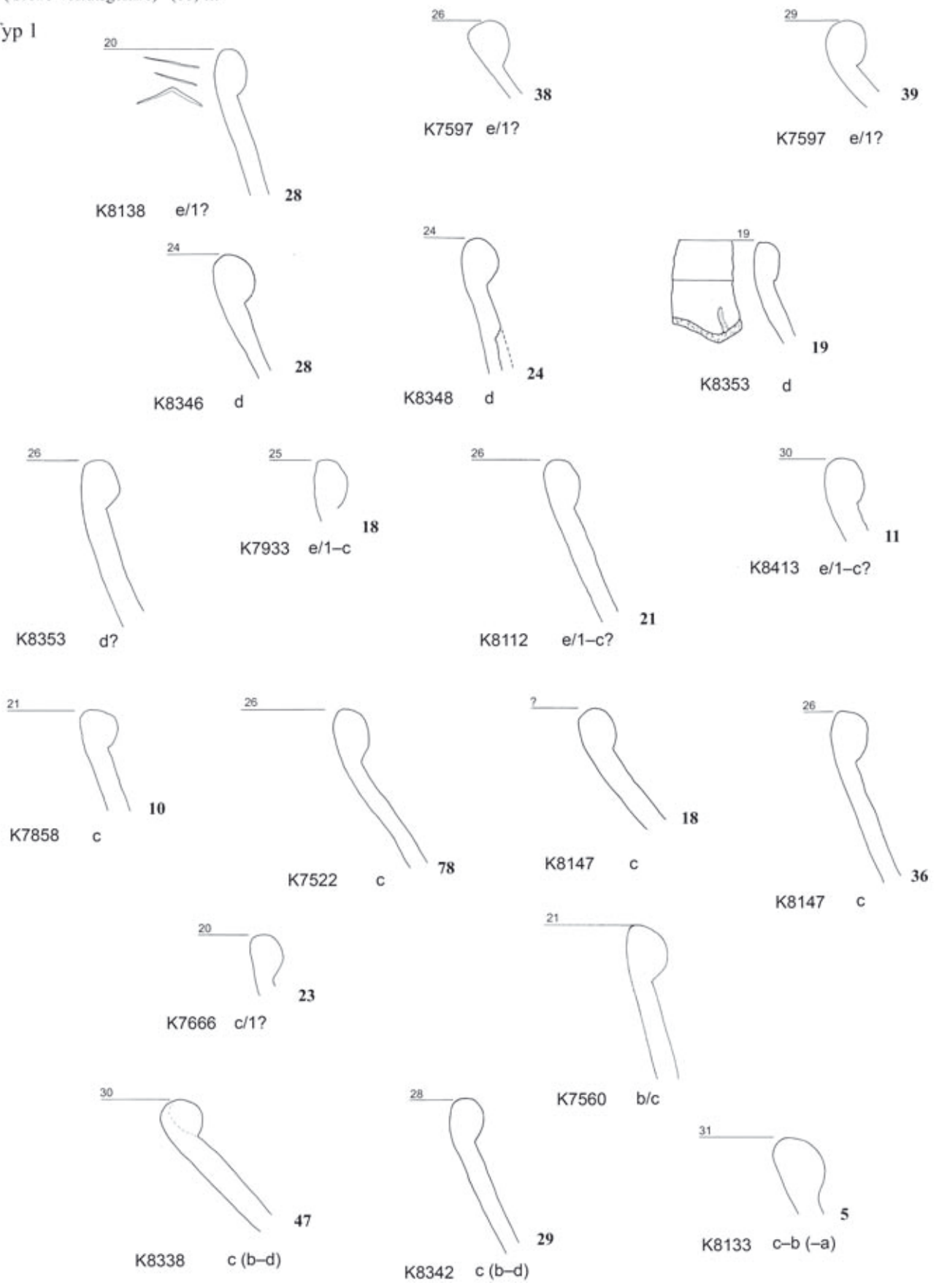

Abb. T90

Zire (Große Vorratsgefäße) (66) ff.

Typ 2

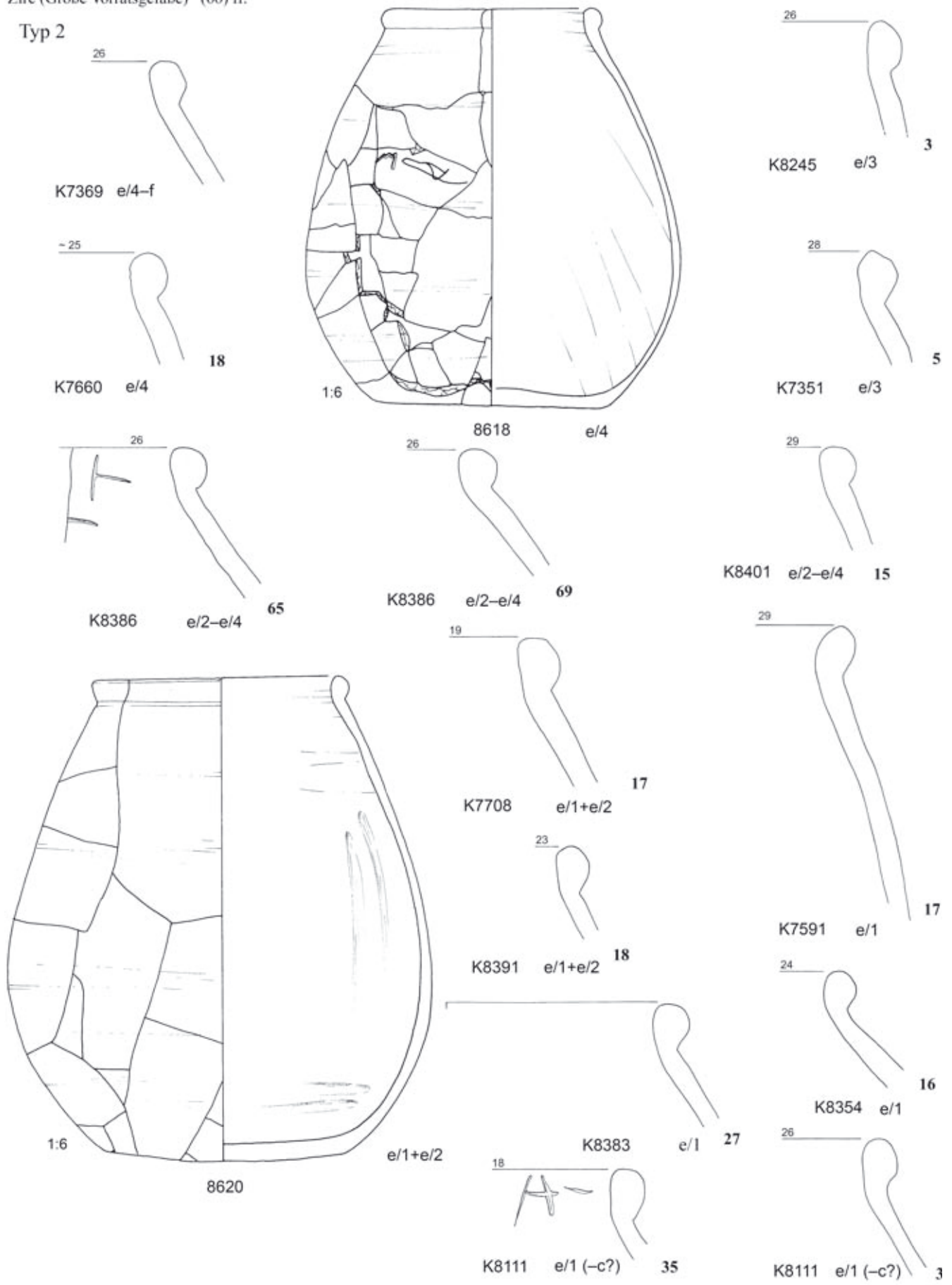

Abb. T91

Zire (Große Vorratsgefäße) (66) ff.

Typ 3

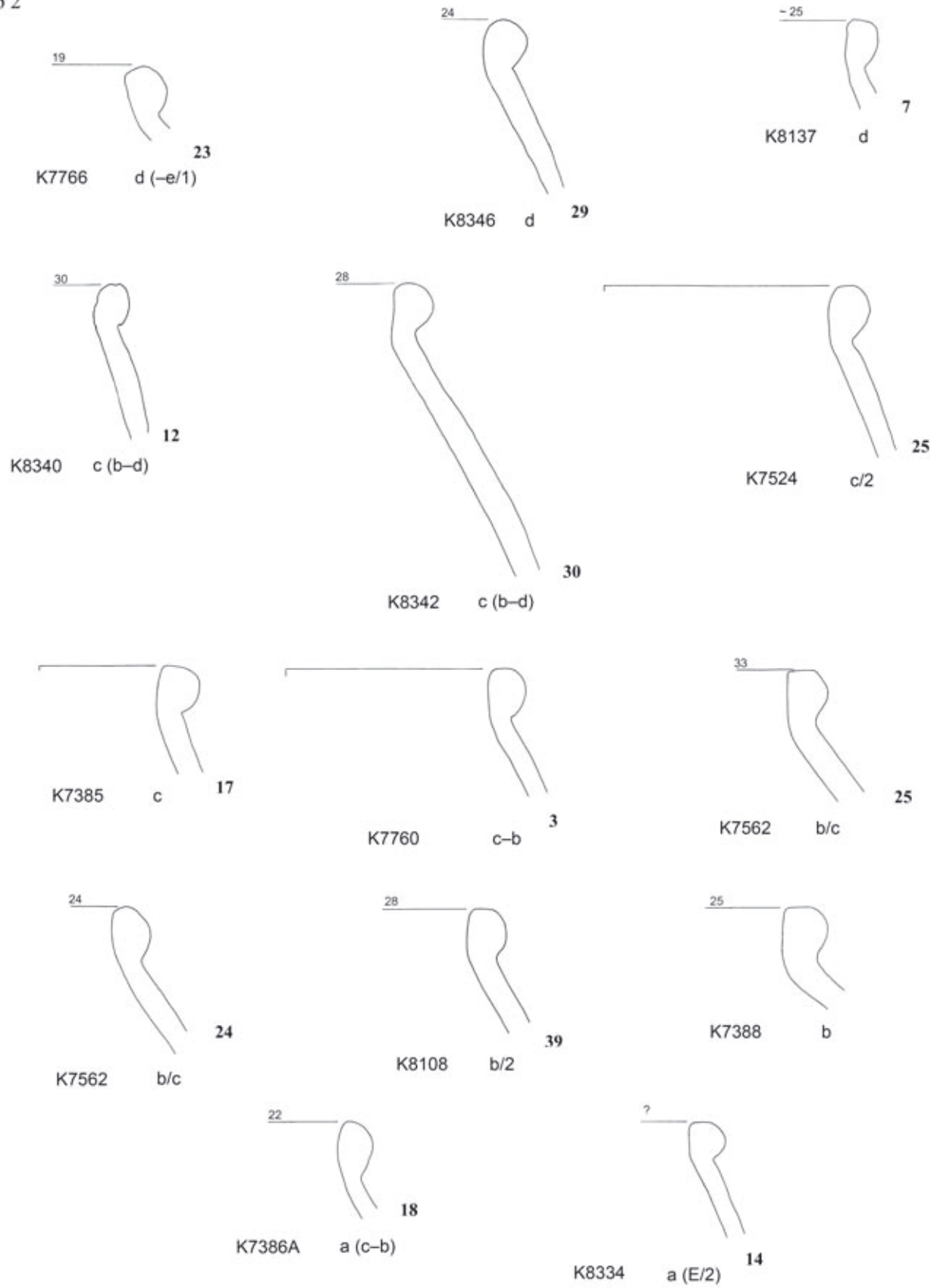

Abb. T92

Zire (Große Vorratsgefäße) (66) ff.

Typ 3

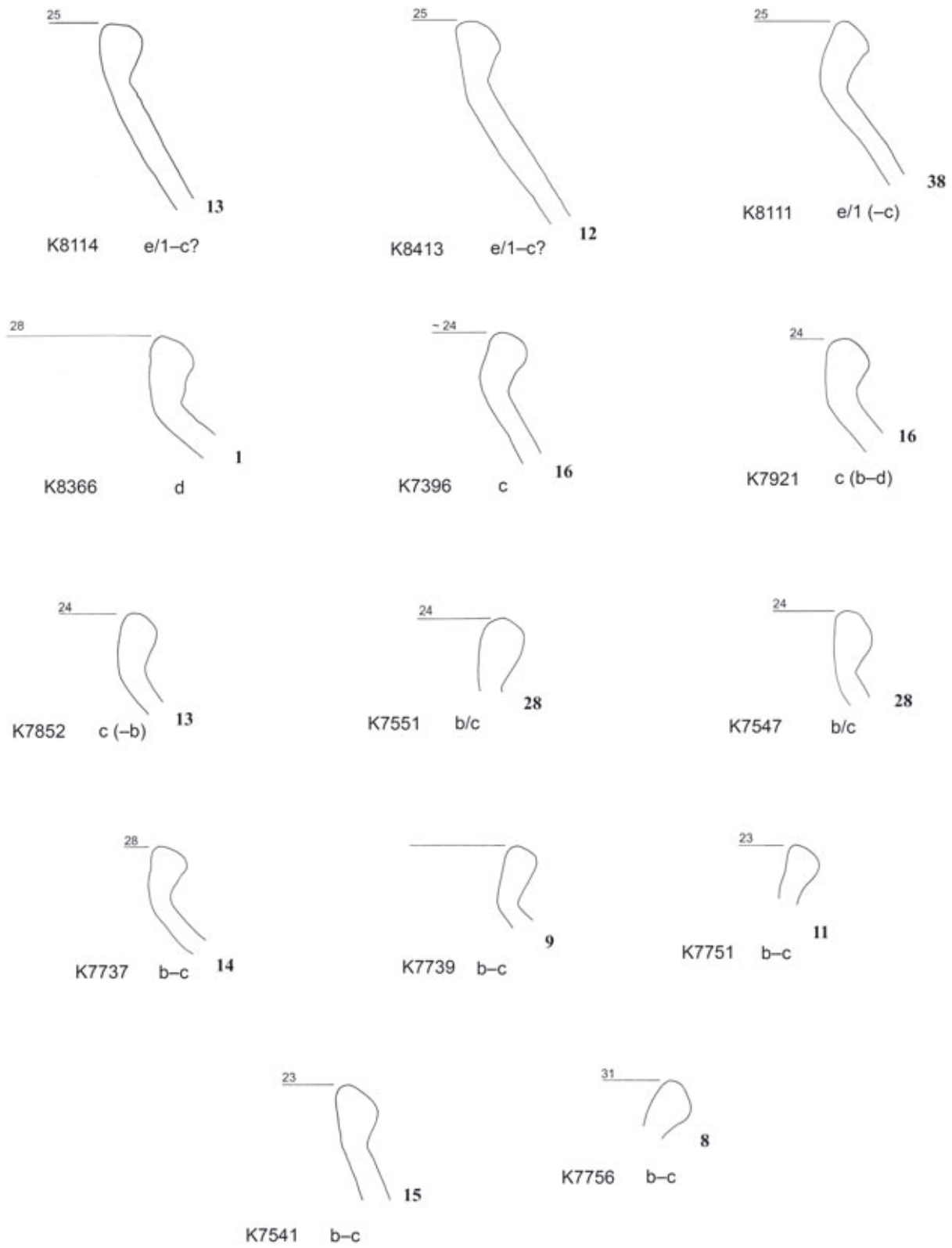

Abb. T93

Zire (Große Vorratsgefäße) (66) ff.

Typ 4/5

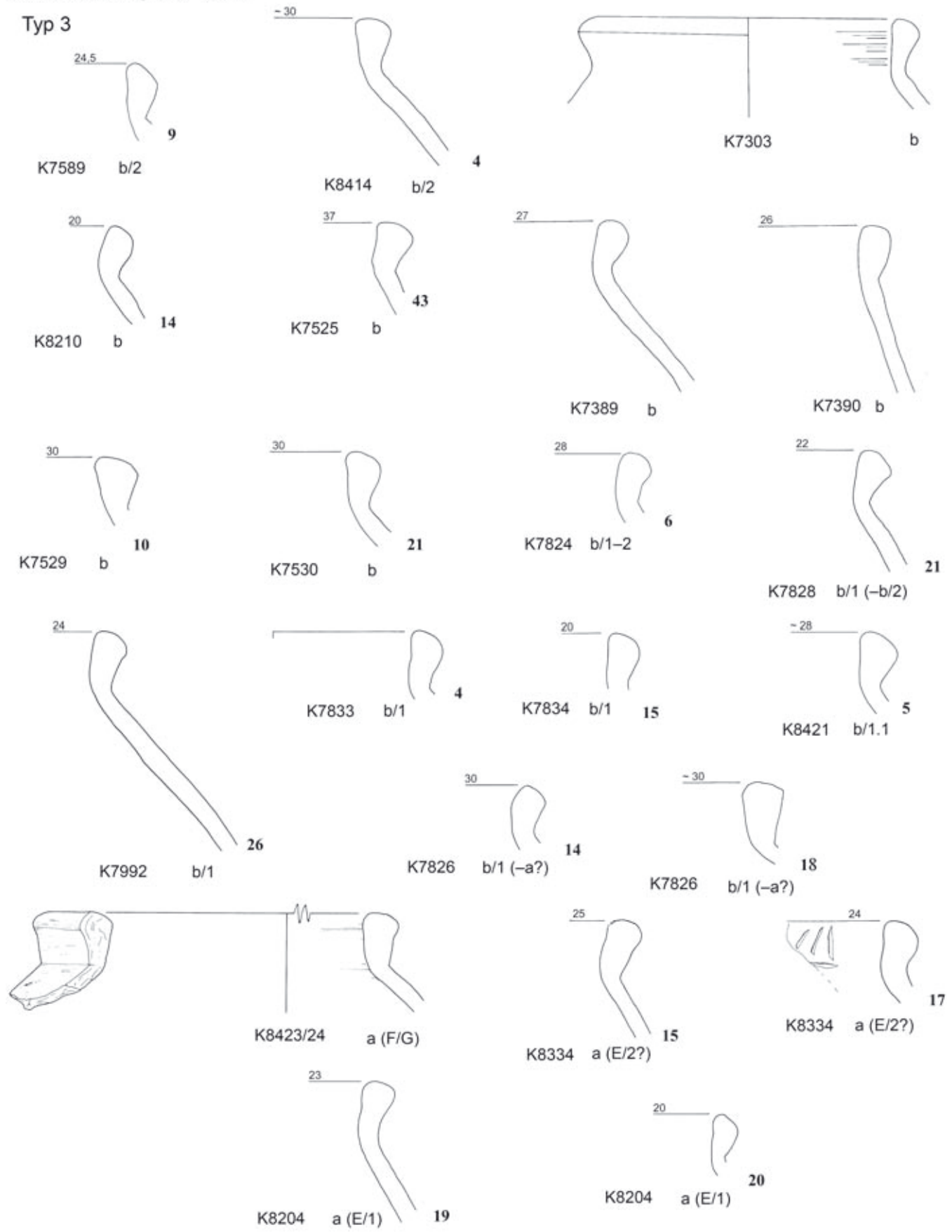

Abb. T94



Abb. T95 Entwicklung der Iic-Zire (nach BIETAK, CZERNY, KOPETZKY)

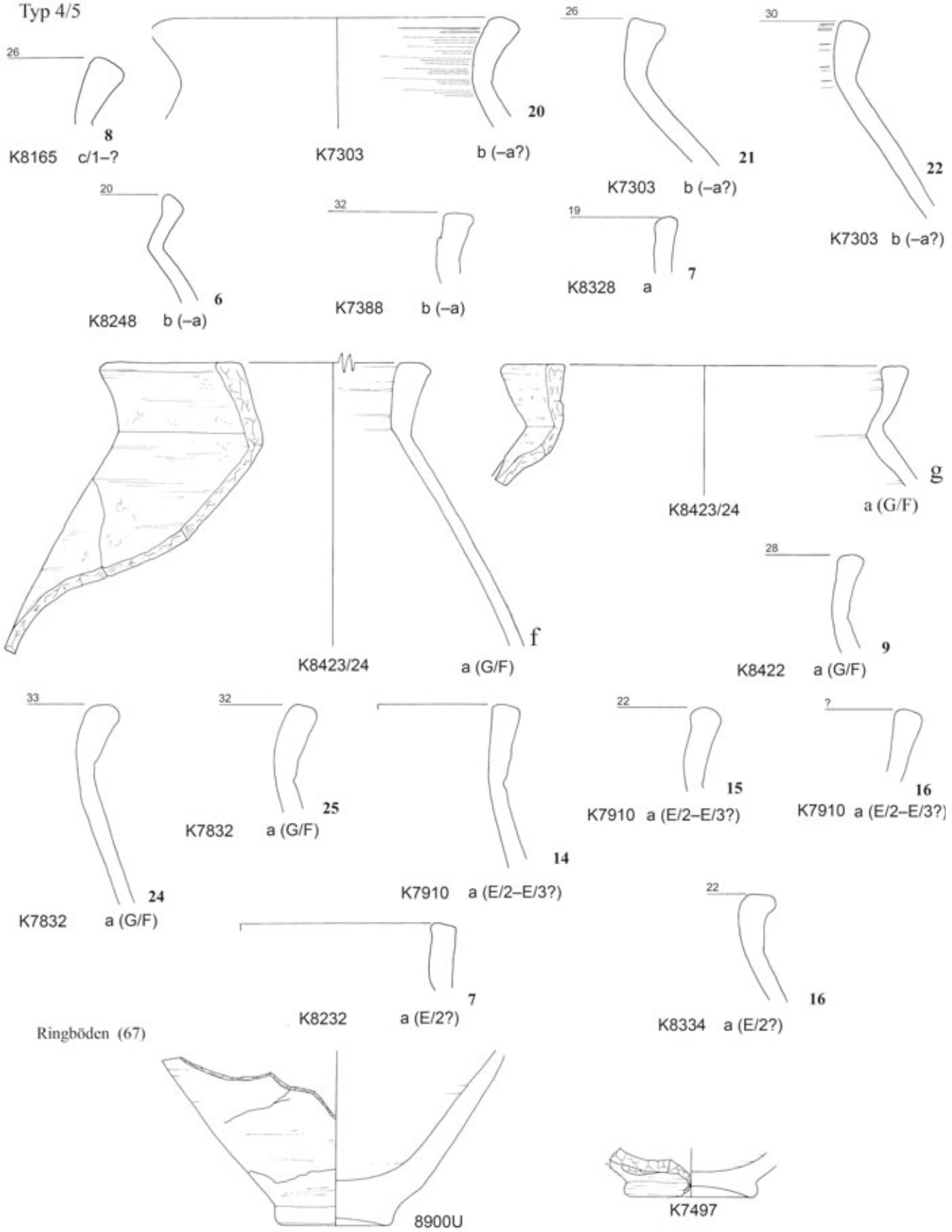

	Zire Typ 1	Zire Typ 2	Zire Typ 3
a	0	2	5
b	0	2	17
c+b; c/b	4	3	8
c	6	5	2
d	5	3	1
e/1	19	5	3
e/2	13	3	0
e/3	15	3	0
e/4	8	3	0
f	3	1	0

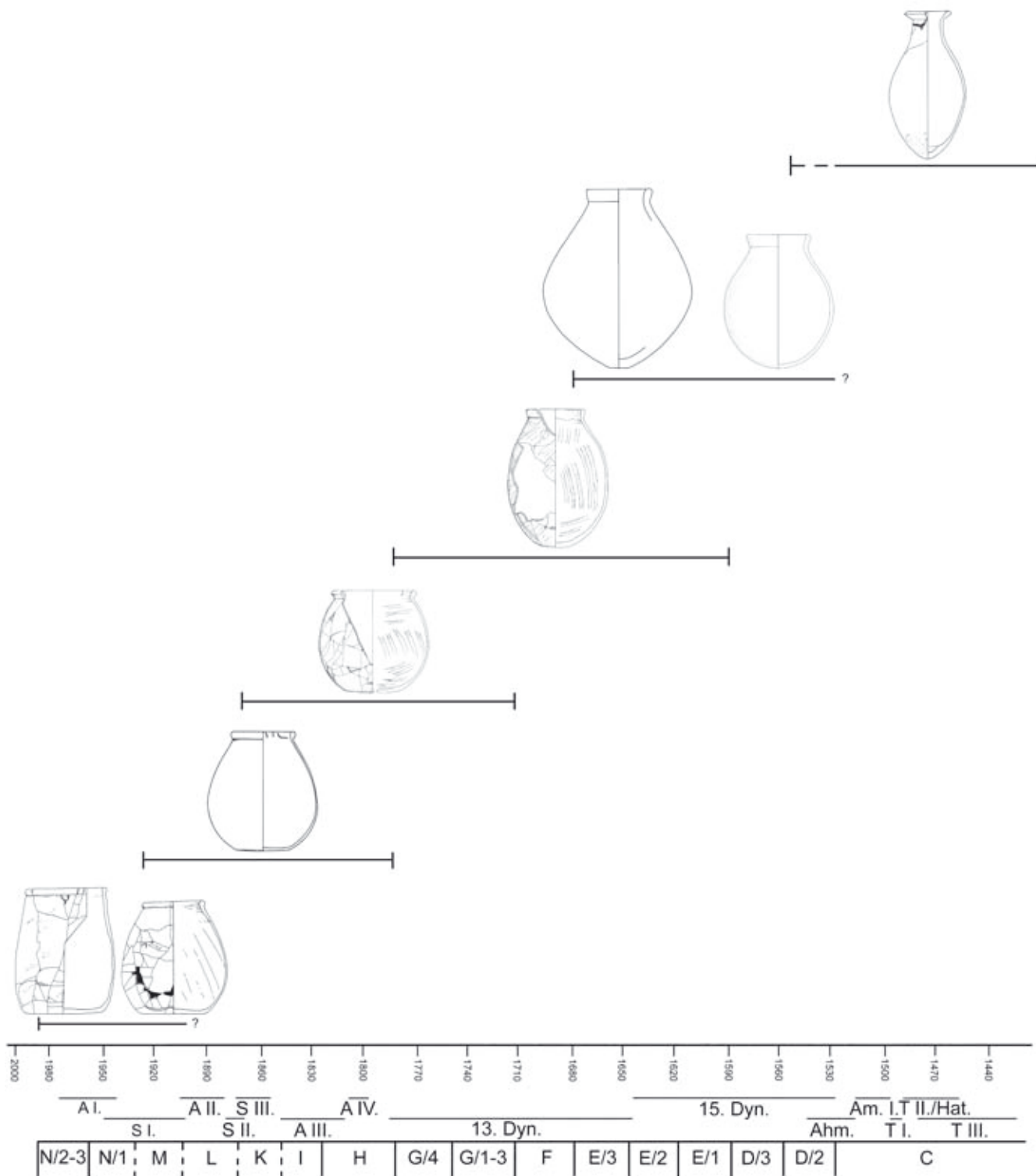

Abb. T96 Zire: Diagramm (Typ 1 – 3)



Abb. T97 Zire: Diagramm (Typ 1, Typ 2, Typ 3)

Spinnschalen (68)

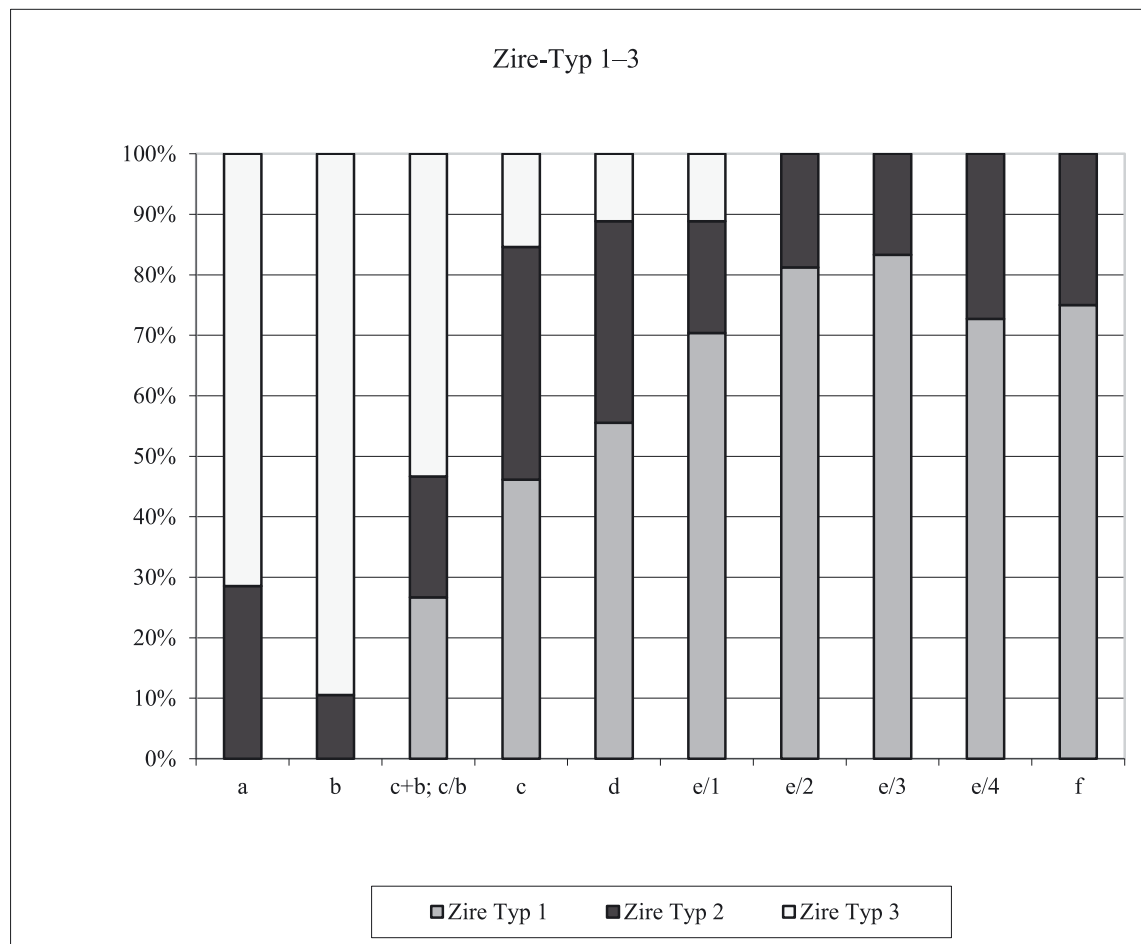

Abb. T98

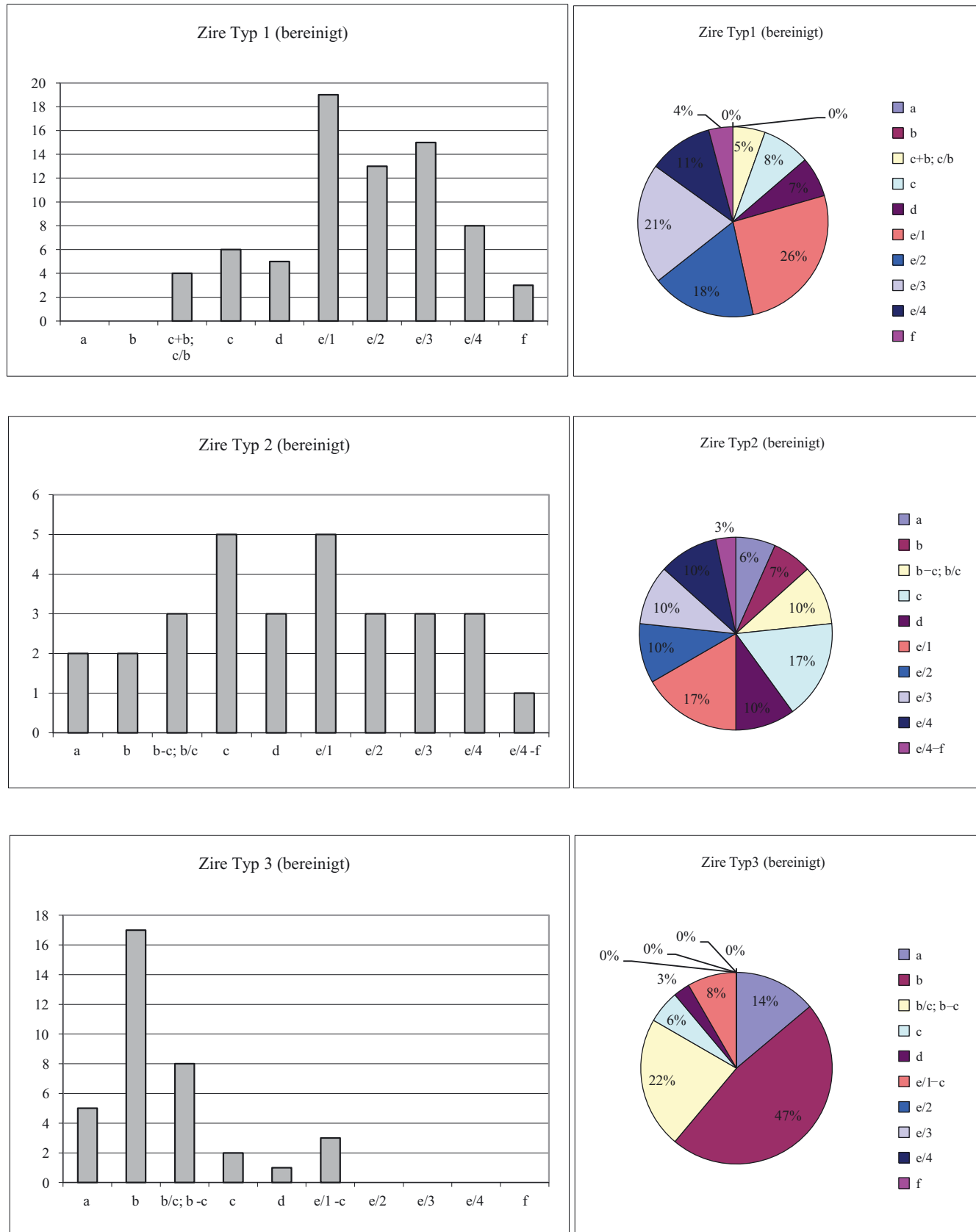
Brotformen (69)

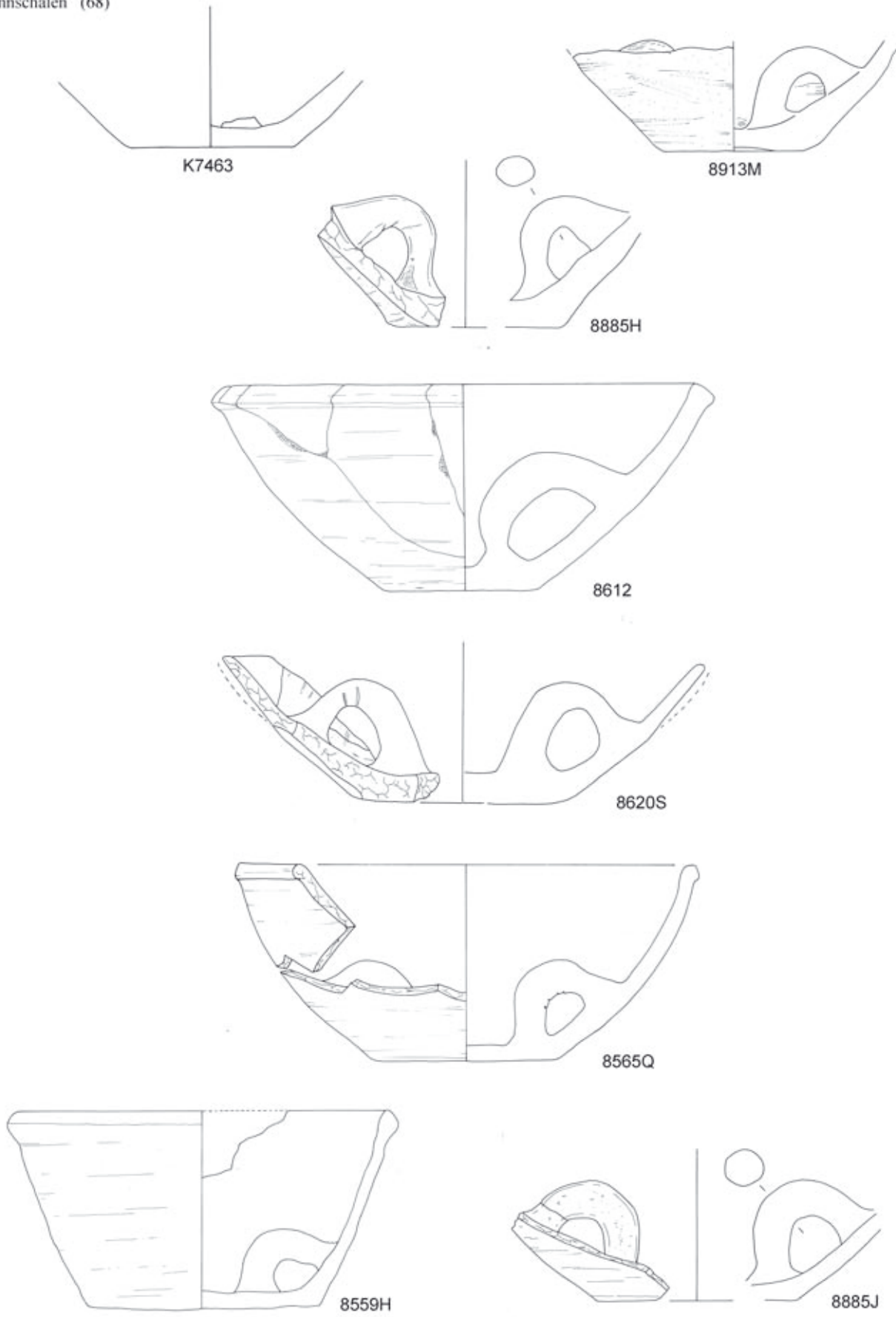

Abb. T99

Brotformen (69) f.



Abb. T100

Backplatten (70)



Abb. T101

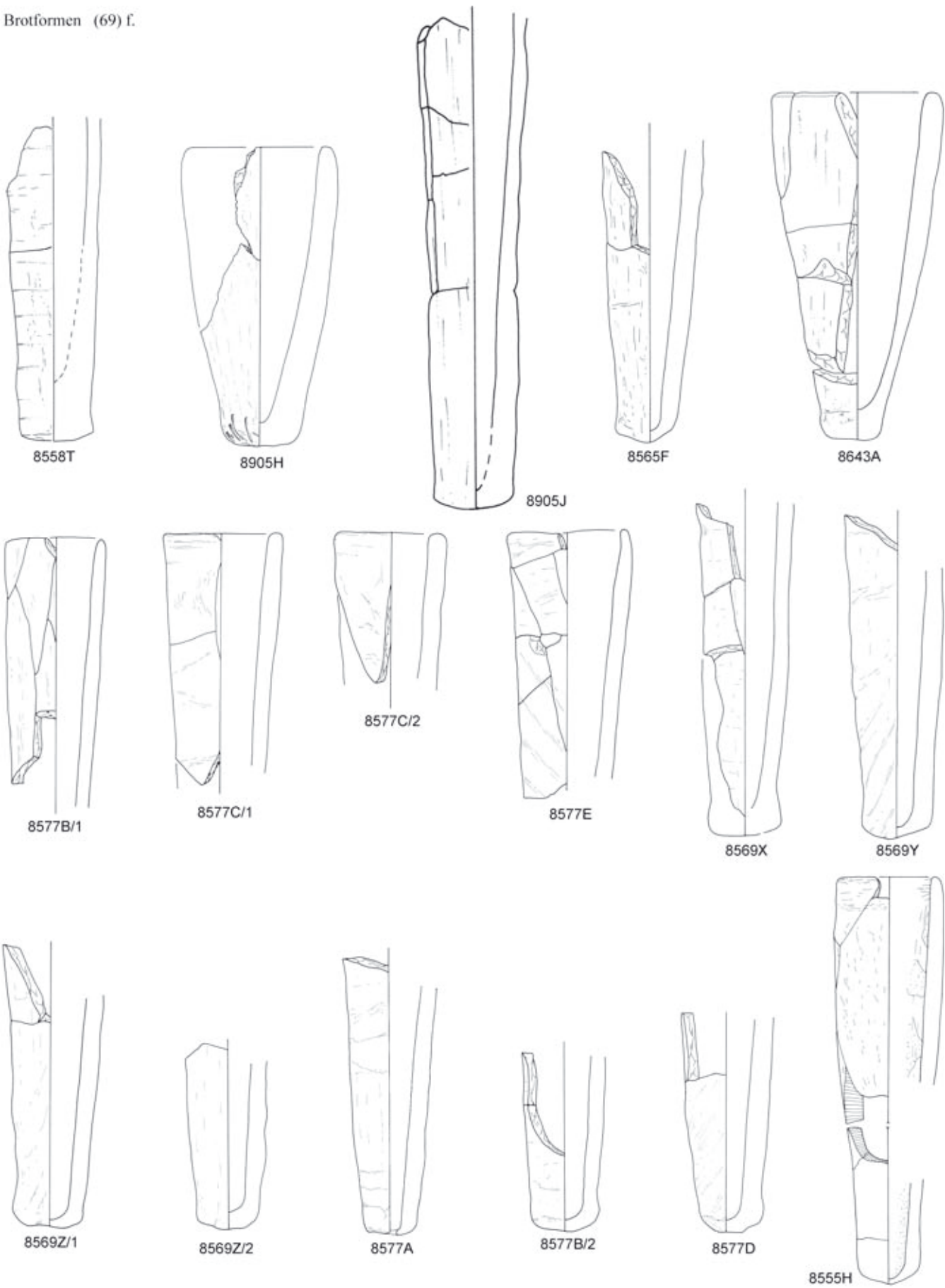

Abb. T102

Kochtöpfe (71) f.

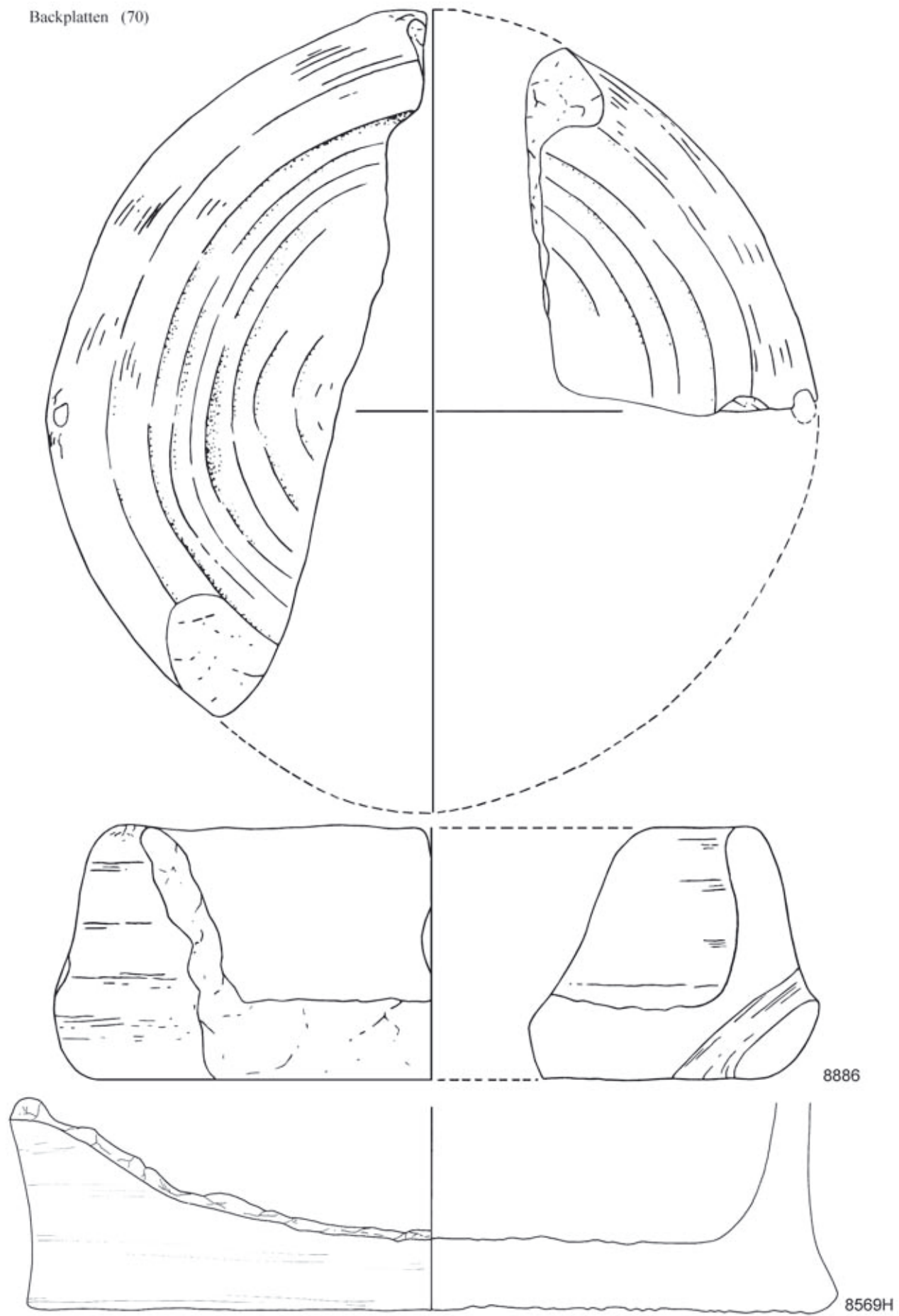

85651

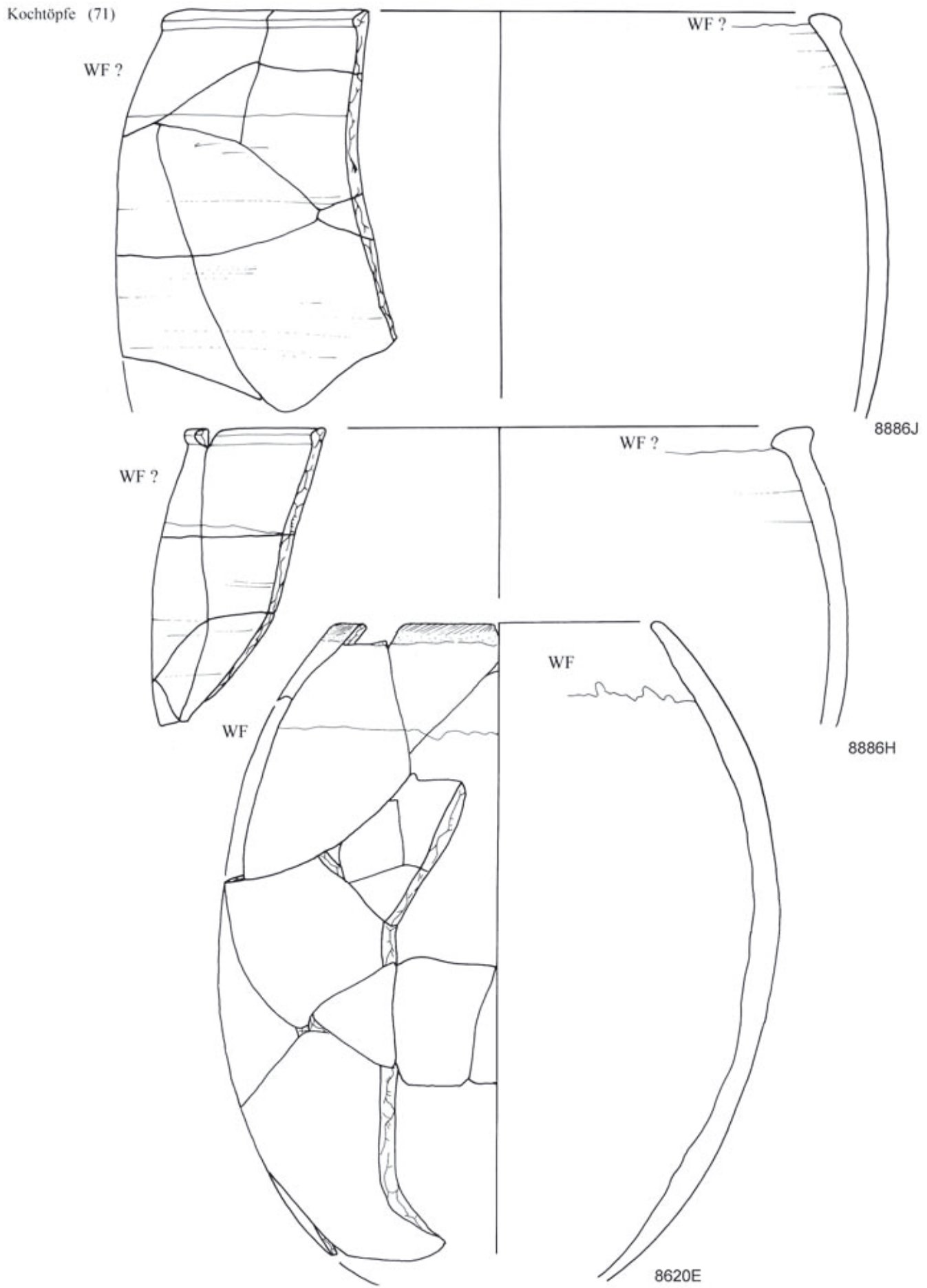

K8424



K8424

Abb. T103



Kochvasen (72)

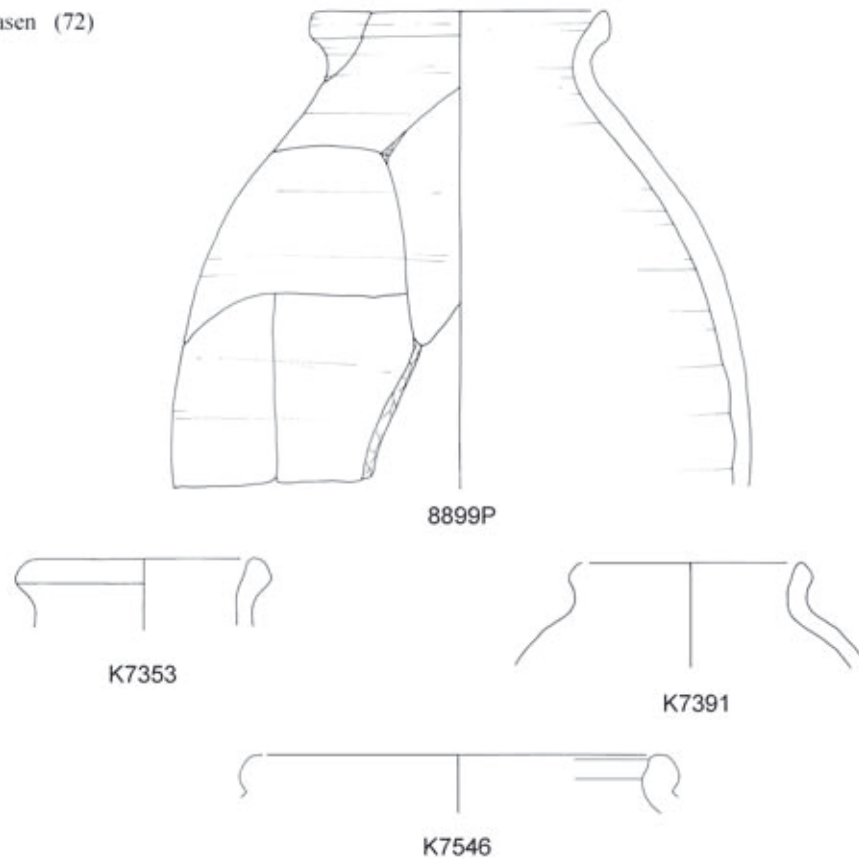

Kochtöpfe mit Gussrand und Ausguss (73)



Böden von Kochgefäßen (74)



Abb. T104



Abb. T105

c) großformatige-dünnwandig (f.)

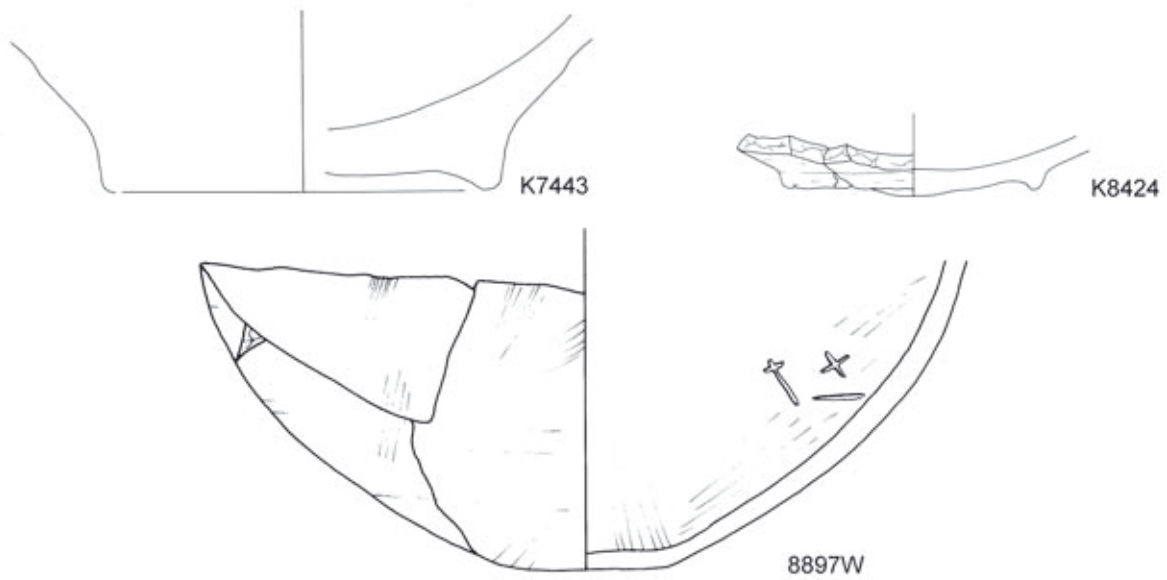

8898T

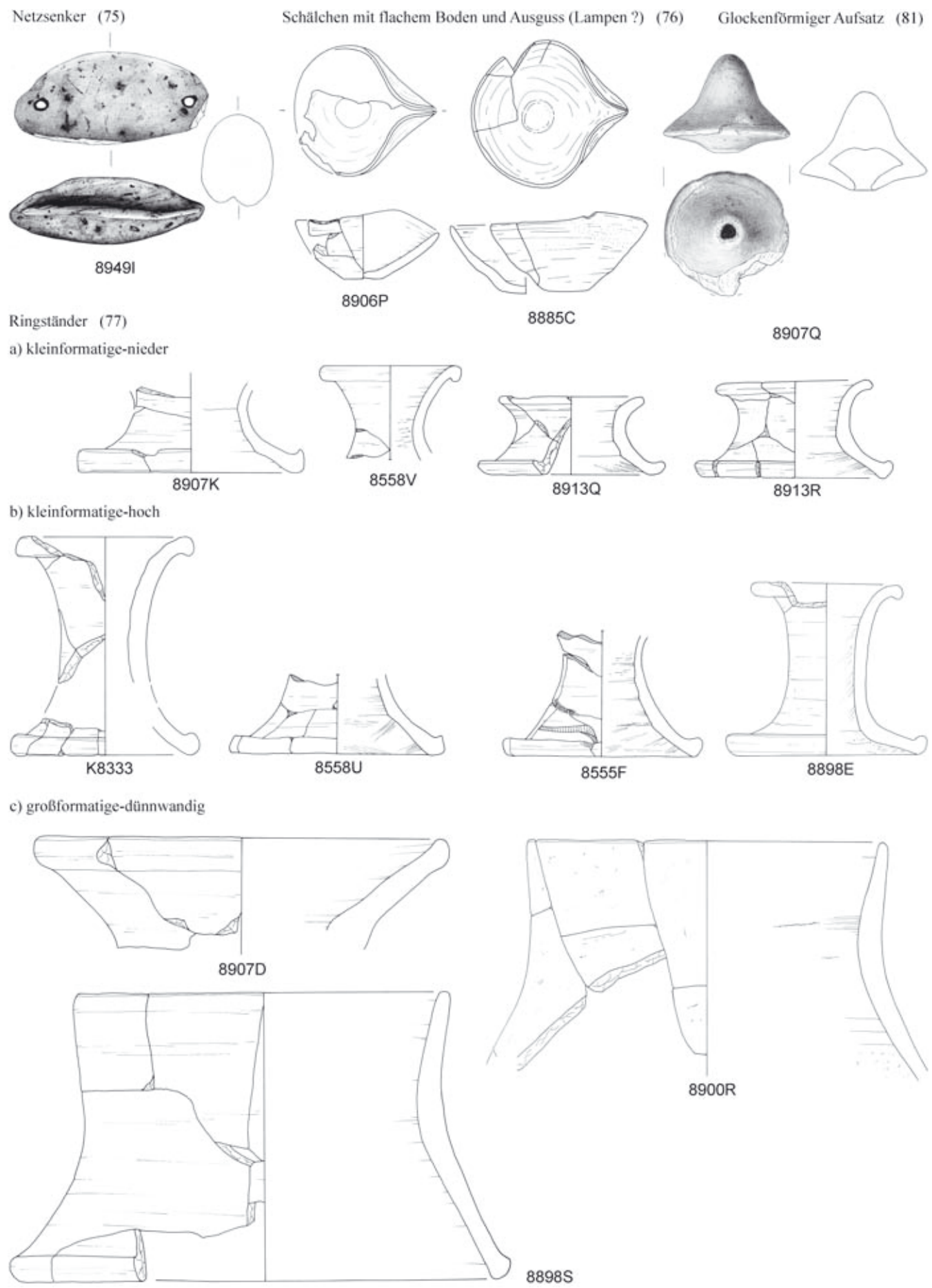
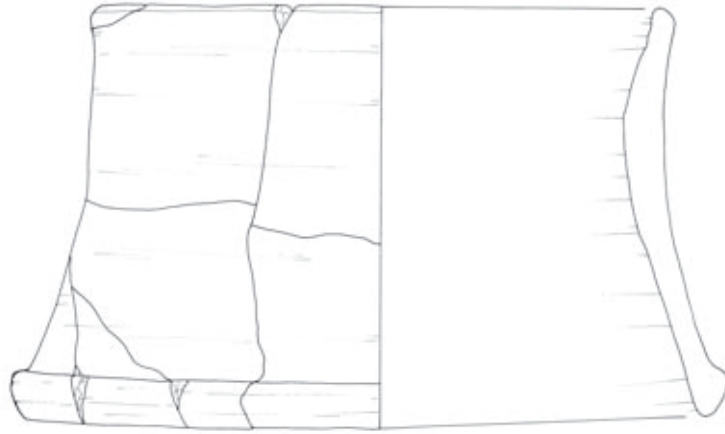
d) großformatige-dickwandig

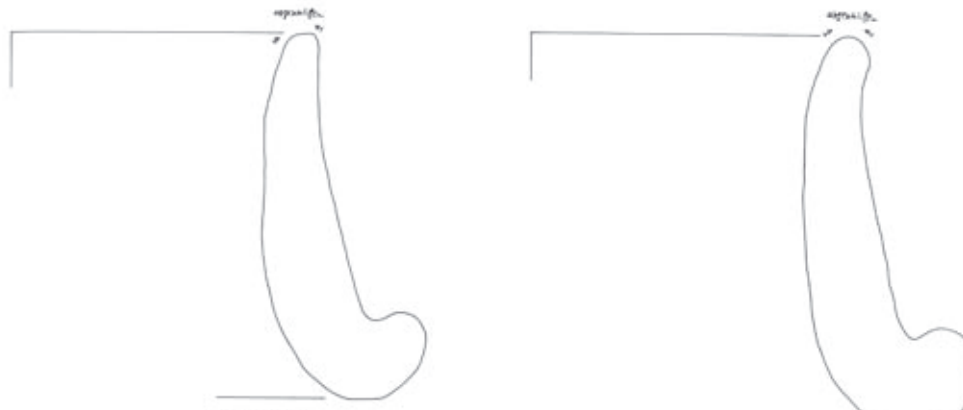

8569T/1

8569T/2

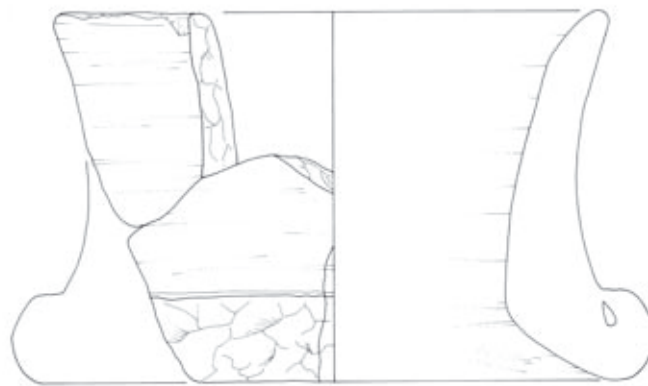

8913S

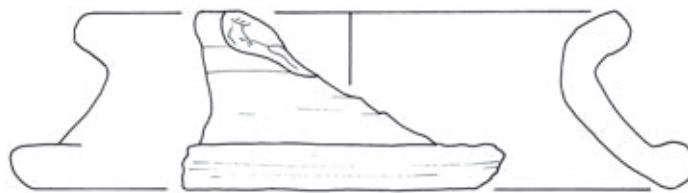

8905L

Abb. T106

Röhrenuntersätze (78)



Abb. T107

Fußschalen auf hohem Fuß (79)



89050

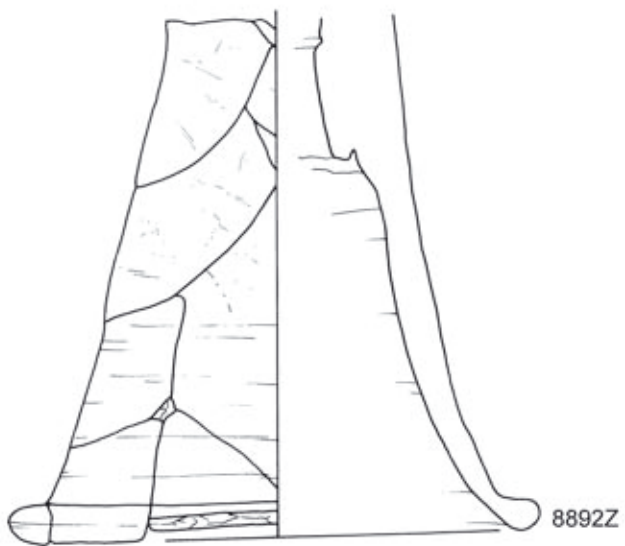
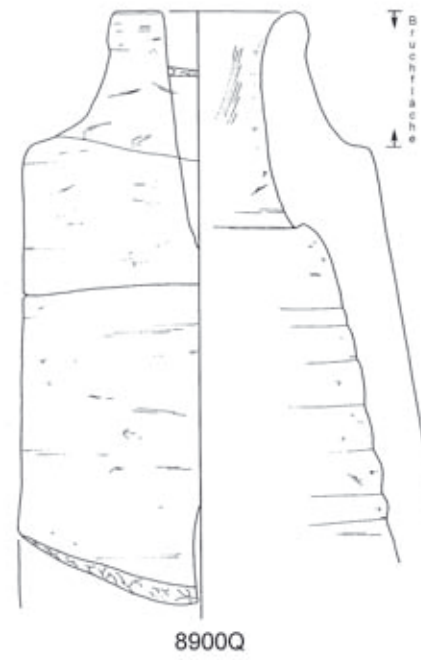
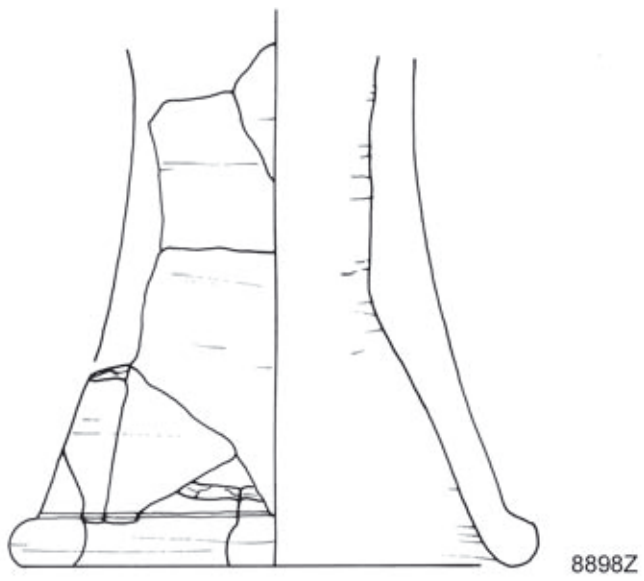
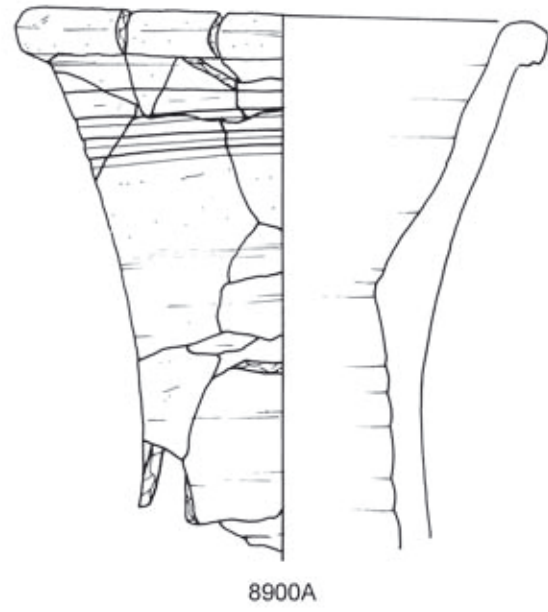
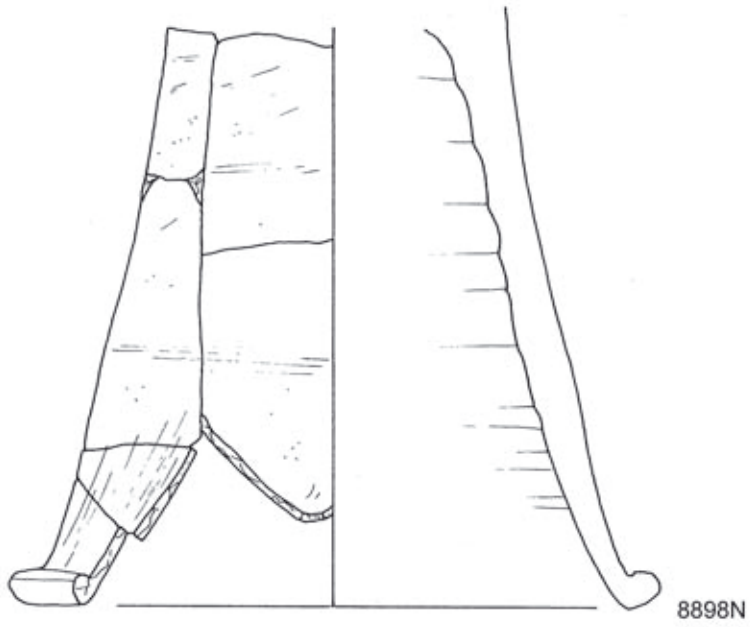
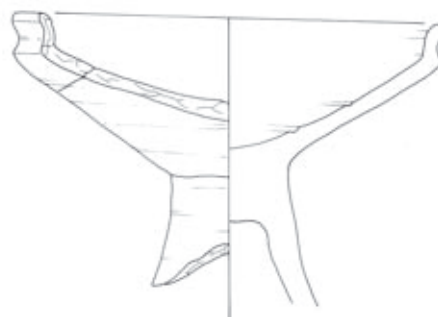

8565T

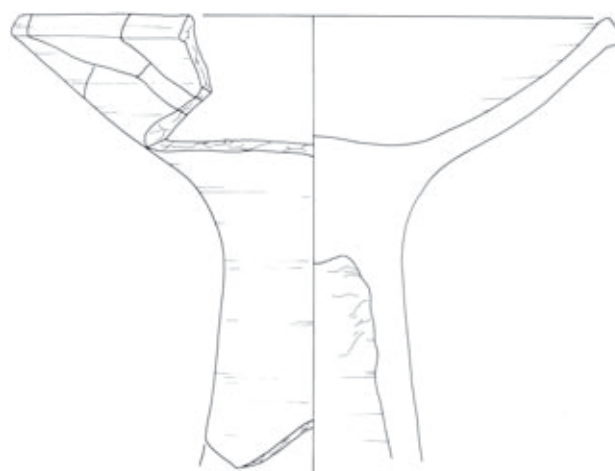

8565U

Abb. T108



Abb. T109



PETRIE, Illahun, Kahun, Gurob, Pl. 4

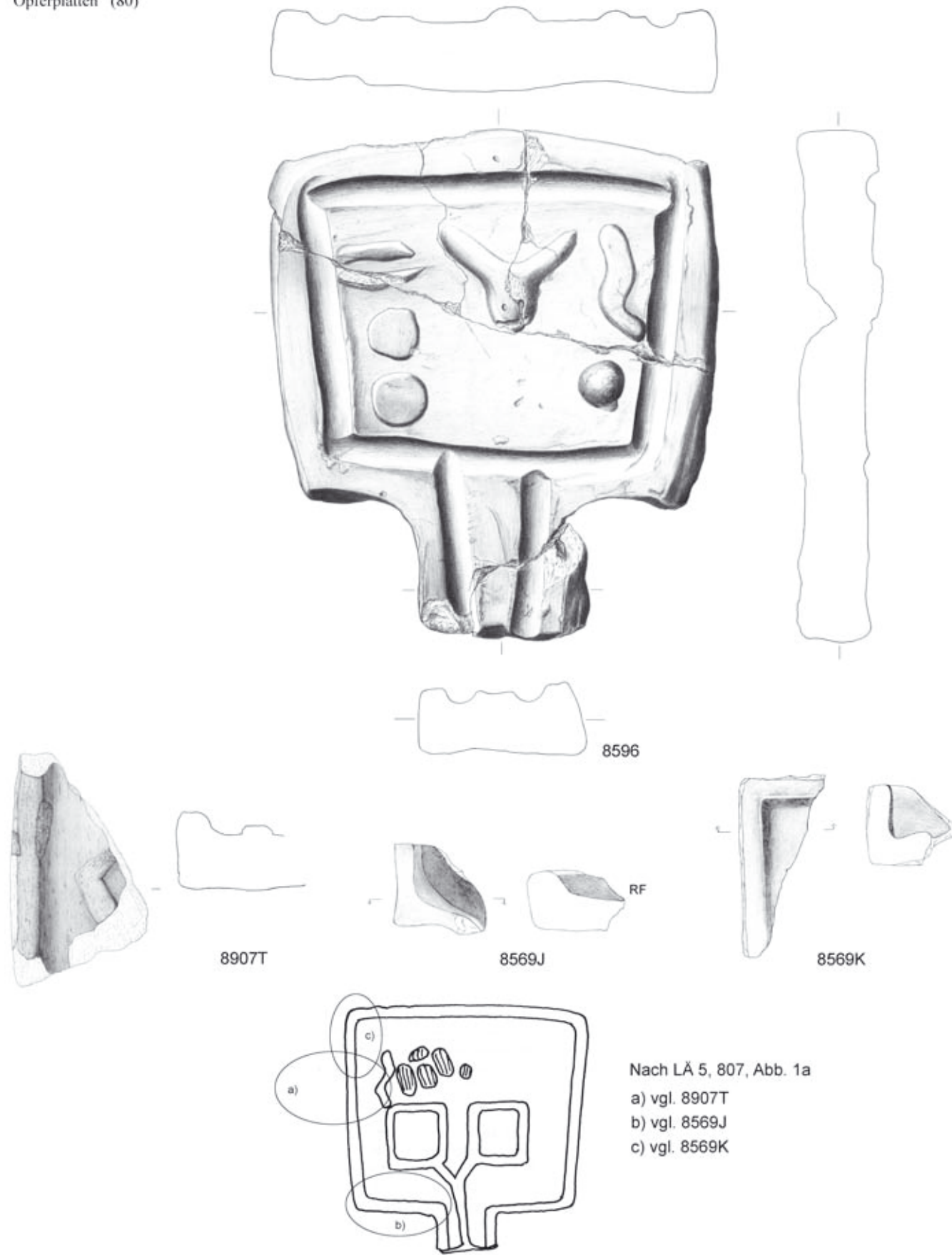
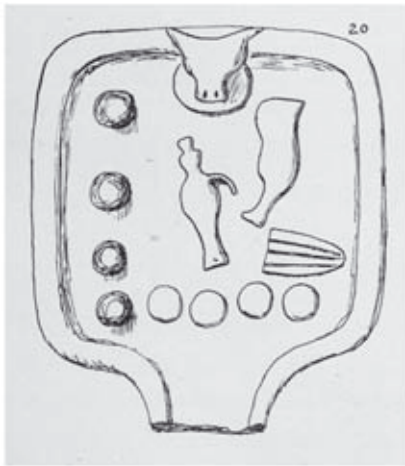
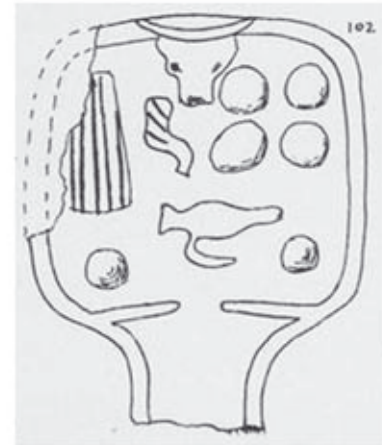

PETRIE, Kahun, Gurob, Hawara, Pl. 13



Glasgow 14-64an

HÖLZL, Opfertafeln, Abb. 2a



PETRIE, Denderah, Pl. 19/2



Liverpool 1973.1.362



PETRIE, Gizeh and Rifeh, Pl. 14



Ezbet Ruschdi, TD 8596

Abb. T110 Opferplatten: Vergleichsstücke

Spitzbodenvasen (Kono) (82)



Abb. T111



Frühe 12. Dynastie

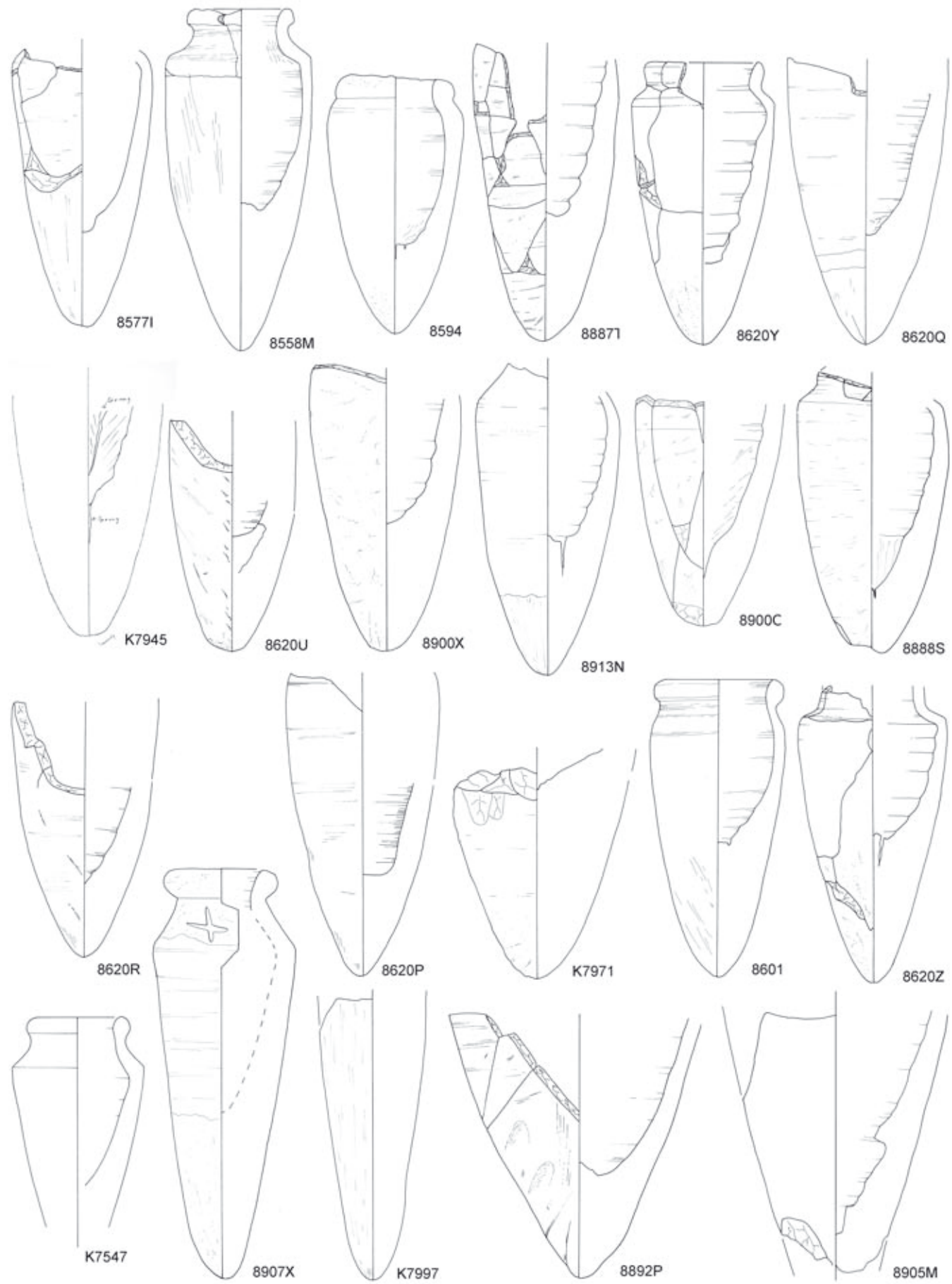
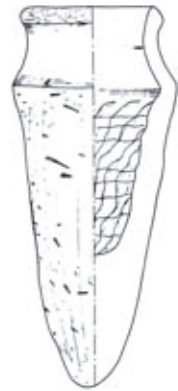

EL 160g BS 14-15



EL 157g BS 14

Späte 12. bis 13. Dynastie

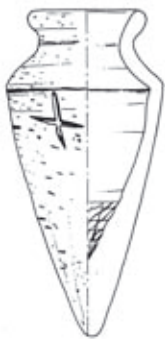

EI 149a BS 13



Abydos-S, East Block ceramic assemblage, WEGNER, *Mortuary Temple*, fig. 125/113

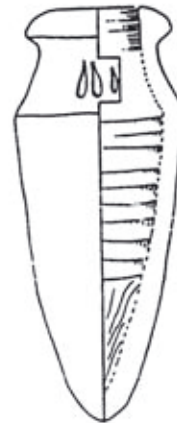

Kahun, *Lahun Studies*, 66, fig. 4/2



13P



13S

Lahun II

13. Dynastie

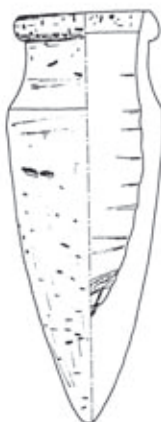

EI 147j BS 12



EI 147k BS 12



13 M

Harageh, Haus 530



TD 3168 (ASTON, TD 12, Nr. 676)



TD 3404E (ASTON, TD 12, Nr. 677)



LM 64.161.20

Abb. T112 Spitzbodenvasen (Konoï): Entwicklung

Levantine Painted Ware (LPW) (83)



Abb. T113 (basierend auf Tine BAGH, *TD XXIII*, 183, Fig. 15)



Abb. T114 LPW: photographische Dokumentation

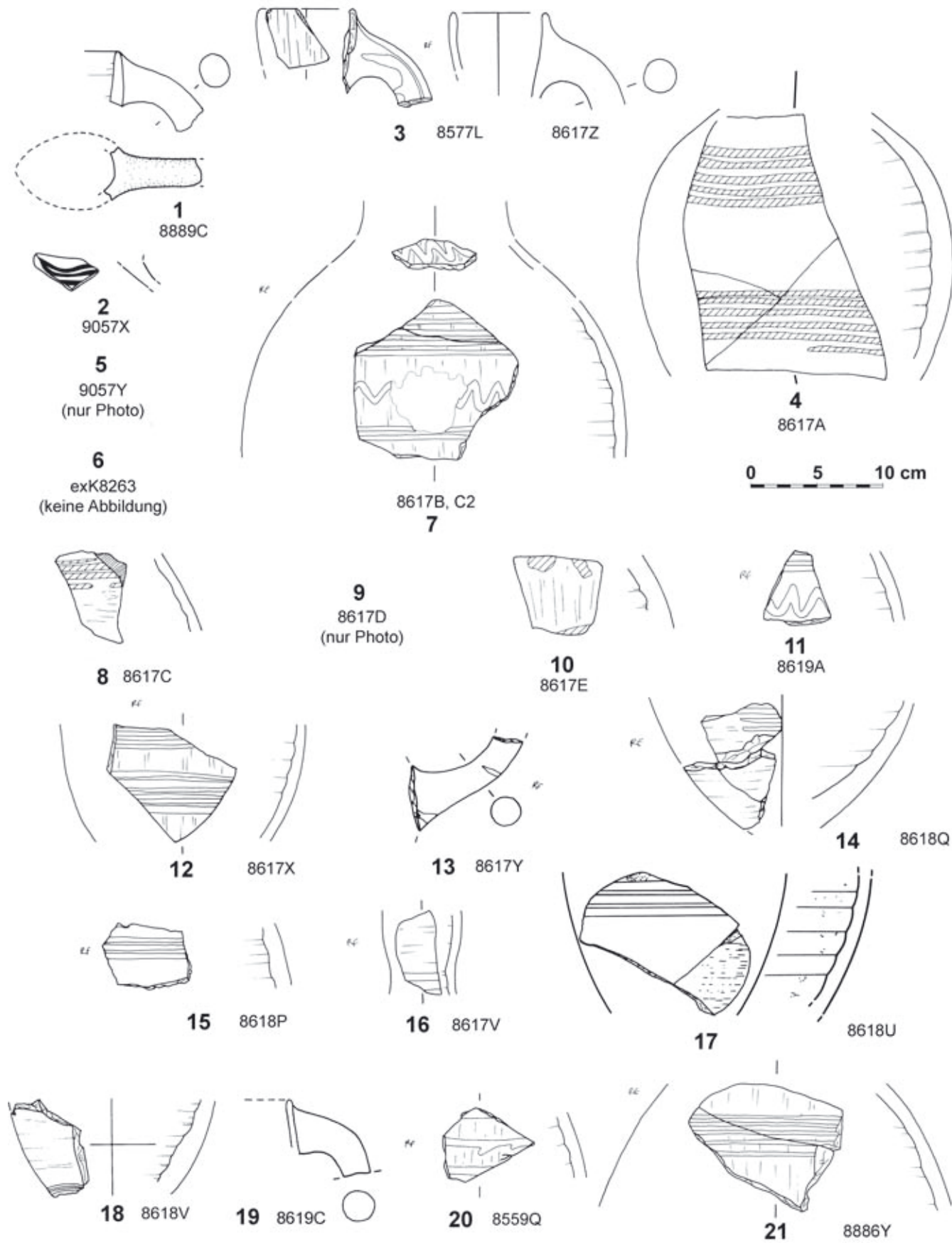

5) 9057Y e/2



7a) 8617B e/1



7b) 8617C2 e/1



8) 8617C1 e/1



9) 8617D e/1



10)

Abb. T115 LPW: fotografische Dokumentation



Abb. T116 LPW: photographische Dokumentation



17)  
8618U  
b/c

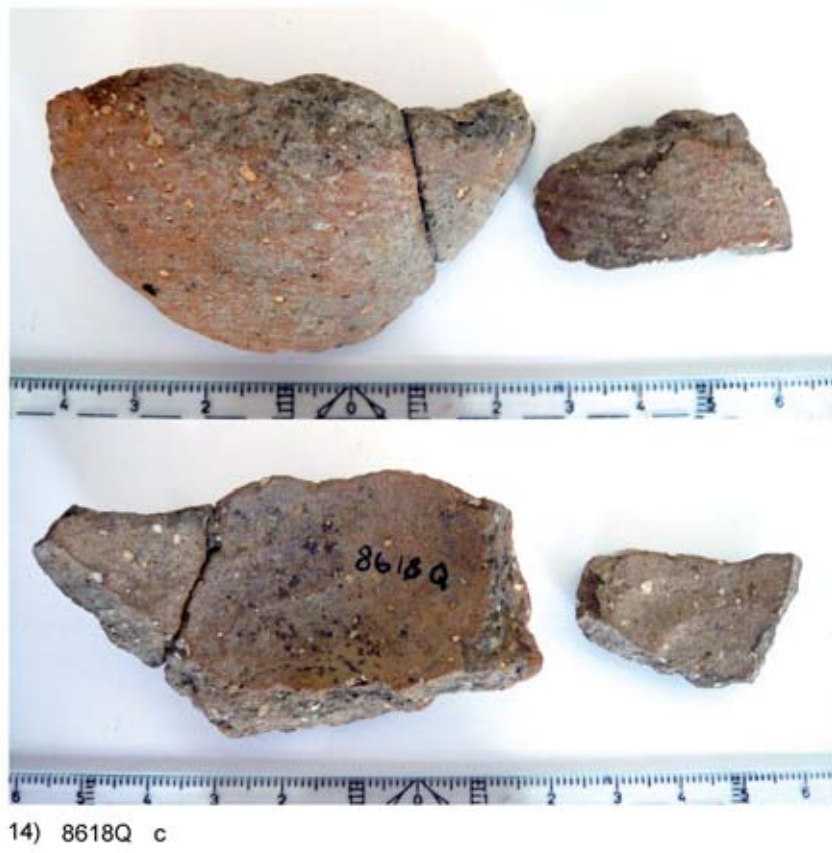

18)  
8618V  
b/c



19)  
8619C  
b/c



20)  
8559Q  
a (E/2?)



21)

Abb. T117 LPW: photographische Dokumentation

Amphoren (84)



Abb. T118

KVs gesamt	1025	100%					
KVs mit IV-Ton	153	15%					
str.	KVs. gesamt (100 %)	davon: IV-Ton	%	davon: Amphore	%	davon: anderes	%
a	51	36	70%	36	100%	9	25%
b	80	19	24%	19	100%	2	10,50%
b-c; b+c; c/b	73	16	22%	14	87,50%	5	31%
c	131	37	28%	23	62%	15	40,50%
d	26	6	27%	3	50%	3	50%
e/1	167	12	7%	6	50%	5	42%
e/1-/+e/2	50	3	6%	2	67%	1	33%
e/2	160	10	6%	4	40%	3	30%
e/2-e/3; e/2-e <sub>i</sub>	41	3	7%	2	67%	1	33%
e/3	123	4	3%	3	75%	1	25%
e/3-/+e/4	29	3	10%	1	33%	2	67%
e/4	64	4	6%	1	25%	3	75%
e/4-f	20	0	0%	0	0%	0	0%
f	2	0	0%	0	0%	0	0%



Abb. T119 IV-Ton: Überblick, Diagramme

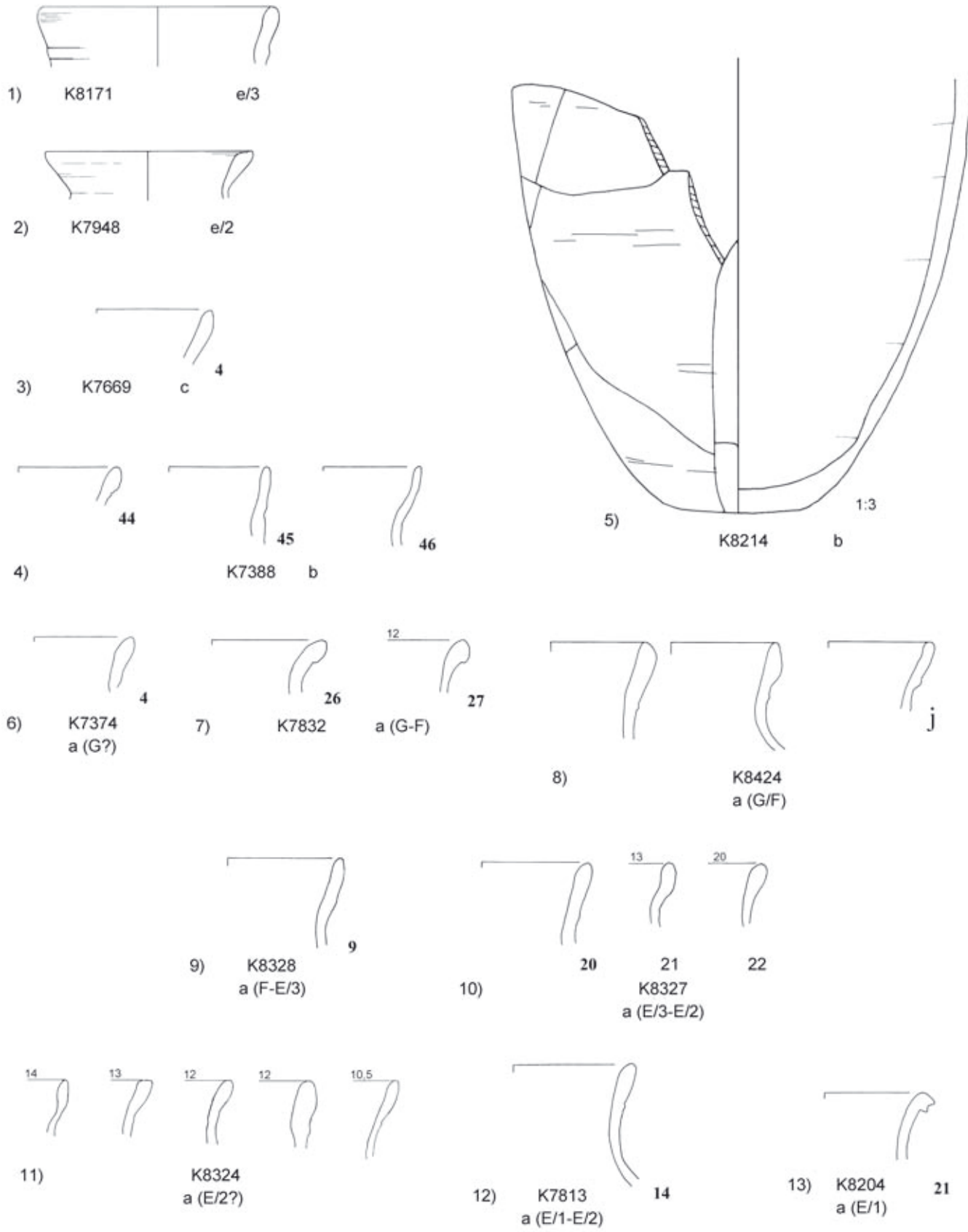

Mittelbronzezeitliche Formen aus Id bzw. IV-Ton (85)

T  
e  
l  
l  
e  
l  
Y  
a  
h  
u  
d  
i  
j  
a

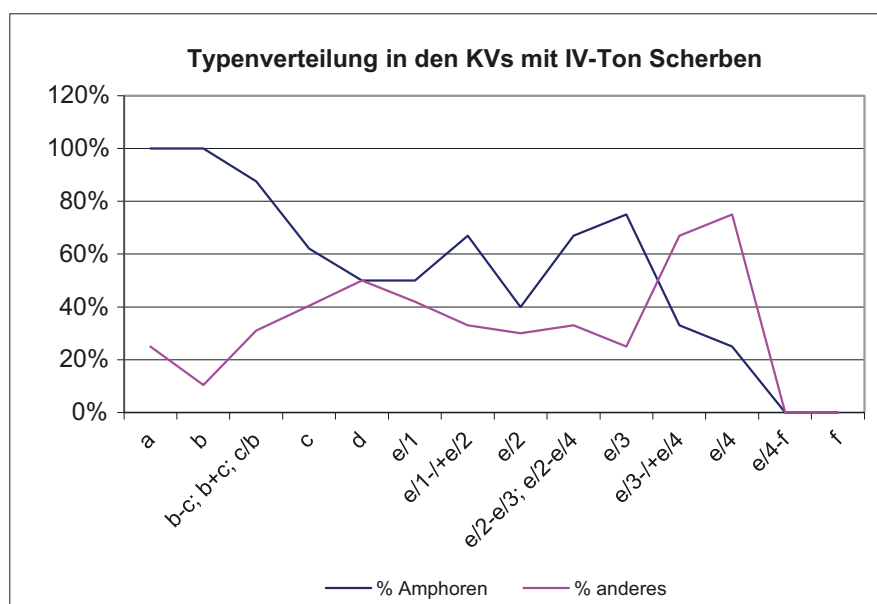
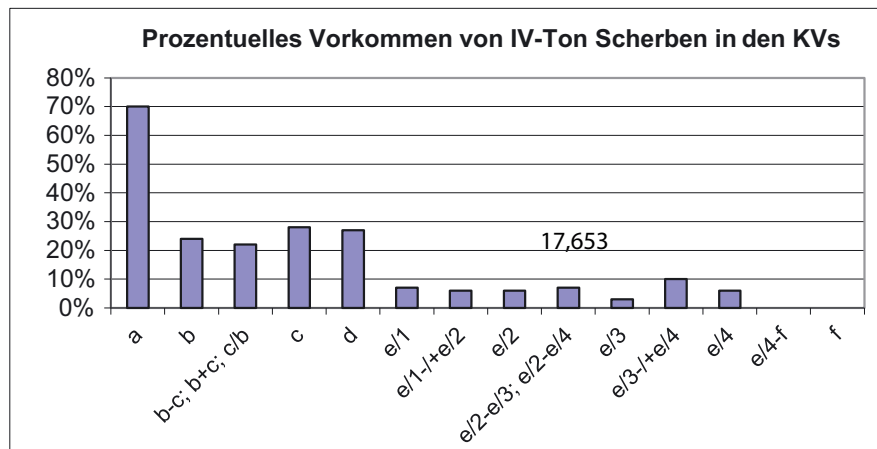
Id

IV



Rl j60  
Grab 1



8926A2



8926A1



K8327  
9145B



K8324  
j/61, Gru.2

k

Tell el Yahudija,  
bemalt



8618S 1,2

m  
o  
n  
o  
c  
h  
r  
o  
m  
p  
o  
l  
i  
e  
r  
t



8565



8927T



8926B



8926C

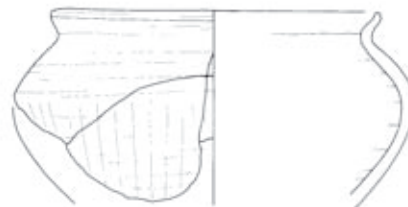

8927U



8889B

tongrundig  
poliert



8928A

Abb. T120

a) Mittelbronzezeitliche  
Formen aus Id  
bzw. IV-Ton (85)



8618S



8565

8565



9145B



8927T



8927U



8889B



8928A



K7972

Abb. T121 MB-Formen: photographische Dokumentation

Keramik aus Kreta (86)



Abb. T122



Abb. T123 Keramik aus Kreta: photographische Dokumentation

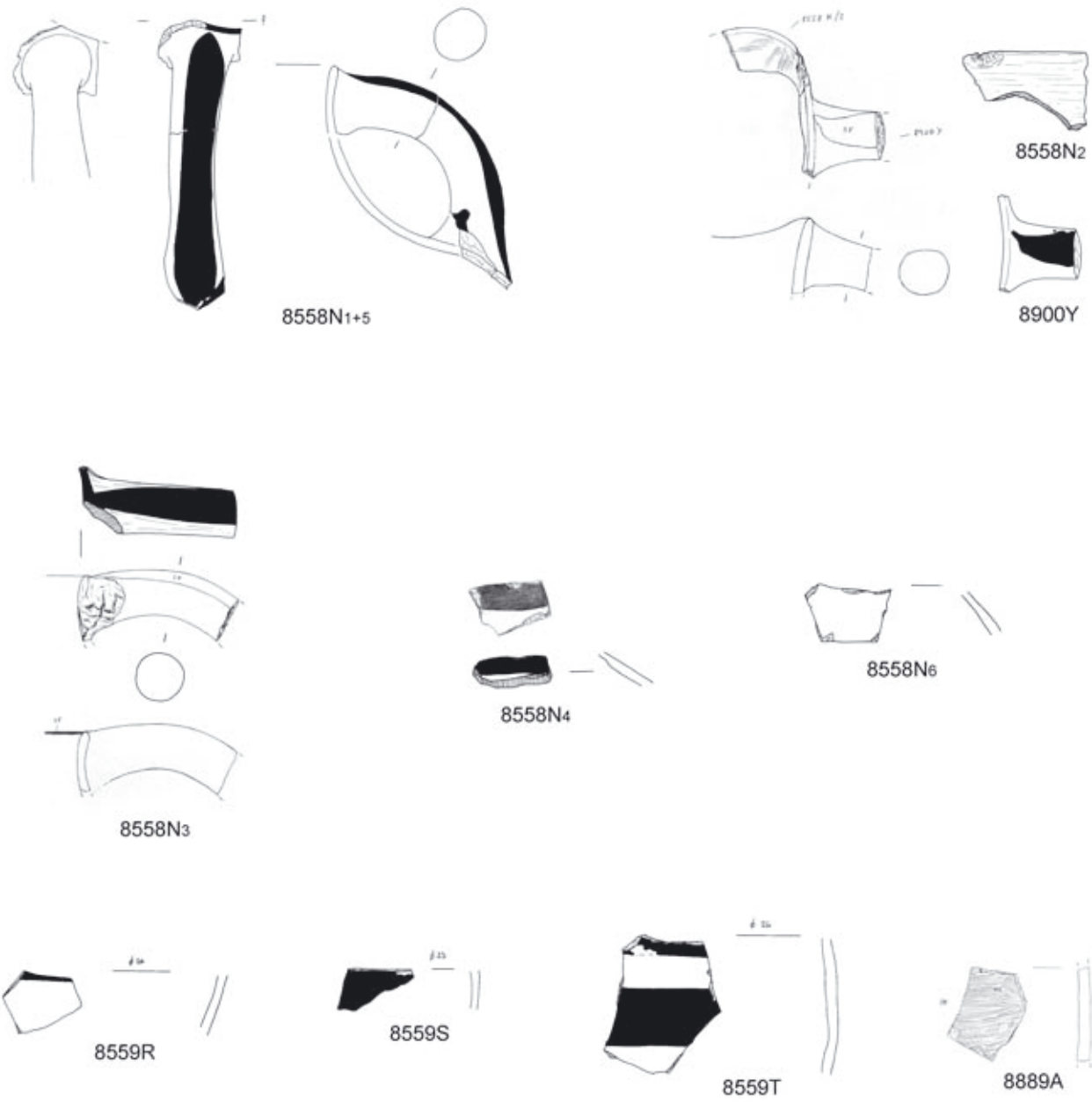

Abb. T124 Keramik aus Kreta: photographische Dokumentation

Keramik aus Zypern (87)



Abb. T125



Abb. T126 Keramik aus Zypern: photographische Dokumentation

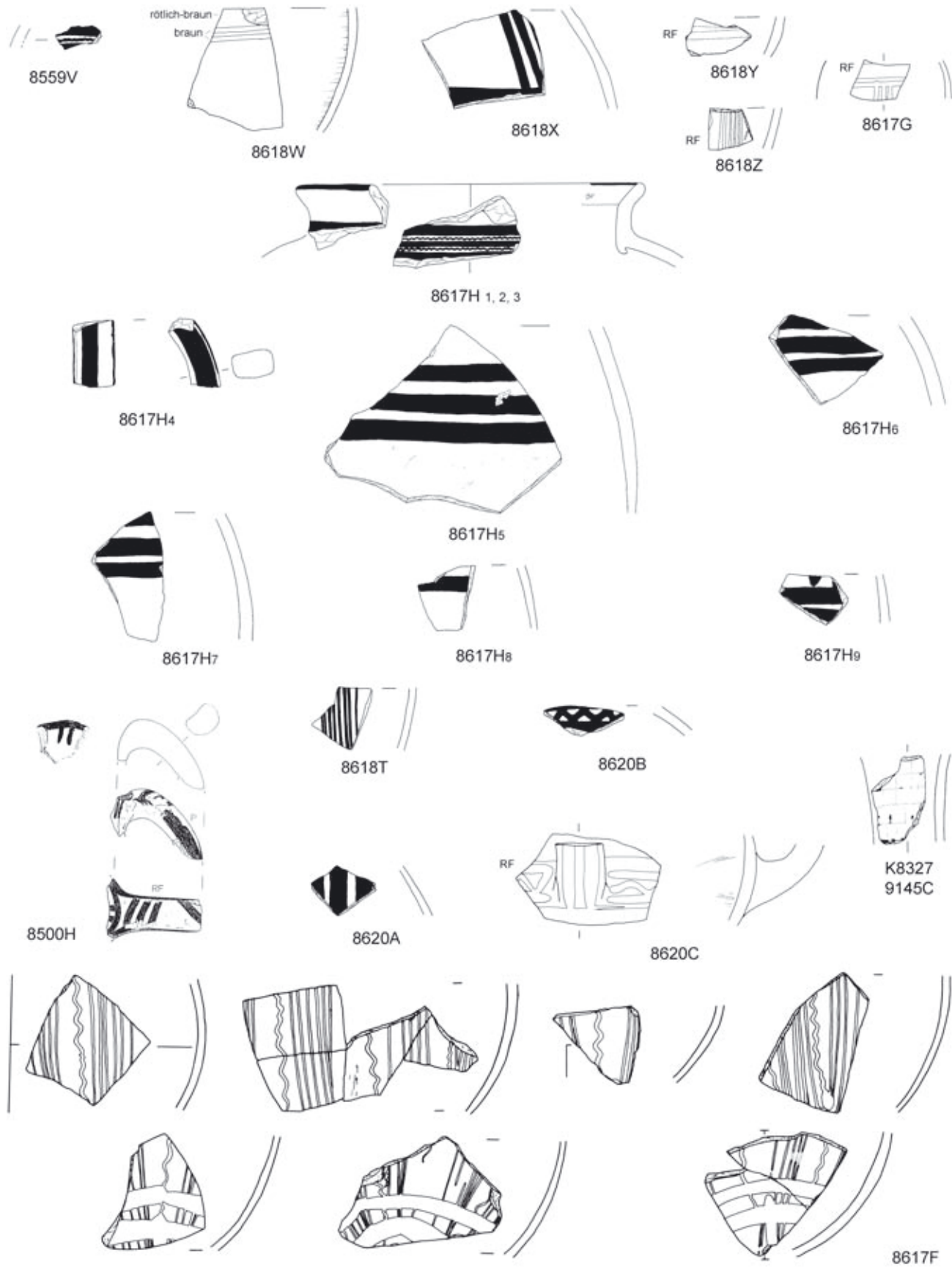

Abb. T127 Keramik aus Zypern: photographische Dokumentation



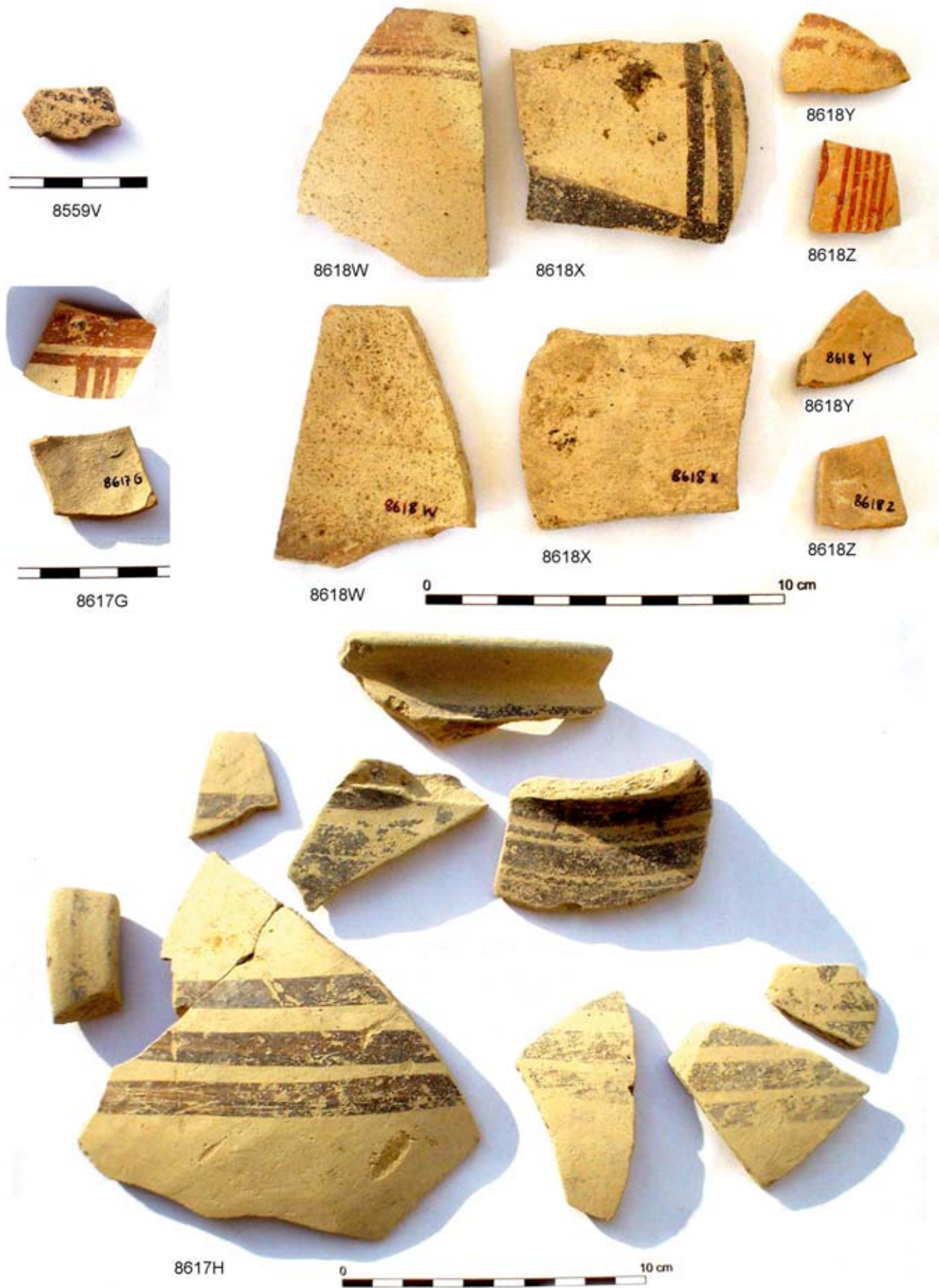

Abb. T128 Keramik aus Zypern: photographische Dokumentation

Figürliche Keramik (88)

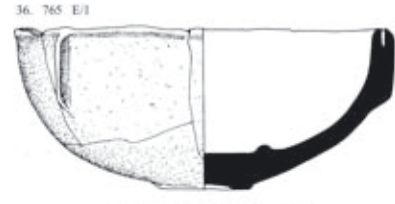
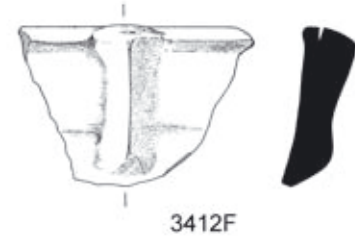
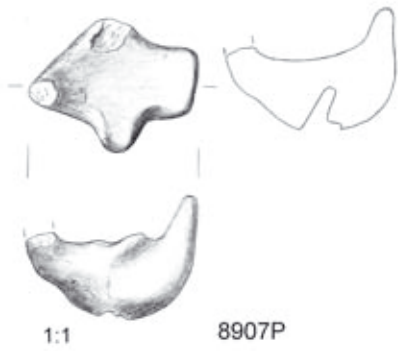

TD 765, ASTON, TD 12, pl. 8/36

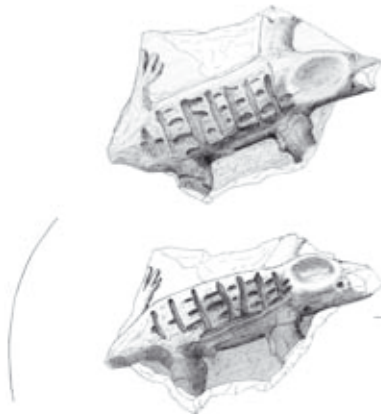

Ø28 cm



PETRIE, *Gizeh and Rifeh*, pl. XIII D



Abb. T129 Figürliche Keramik, Vergleichsstücke

Tonscherben als Bildträger für Ritzzeichnungen (89)

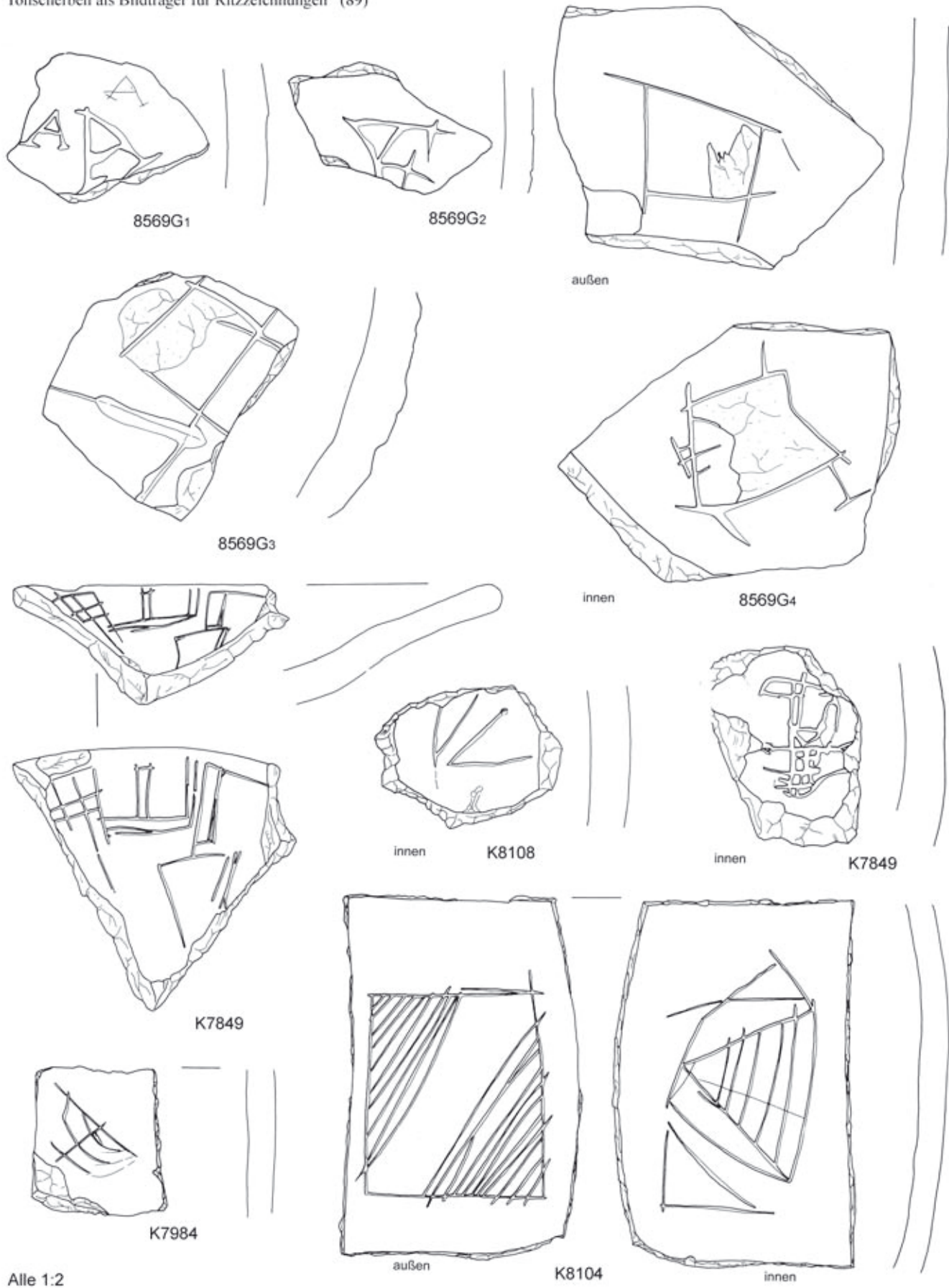

Alle 1:2

Abb. T130

Gefäße aus Hartgestein

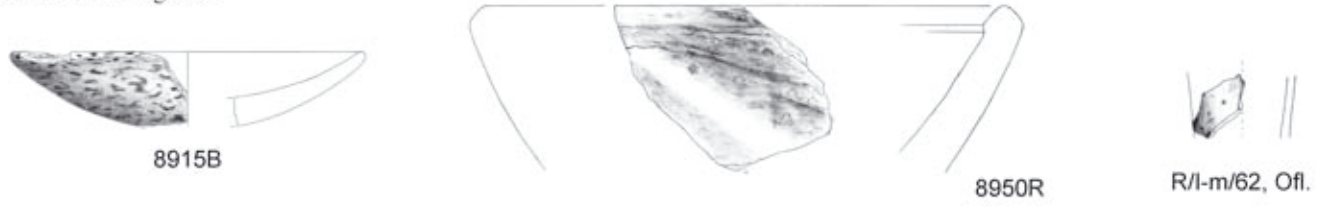

Gefäße aus Kalkstein

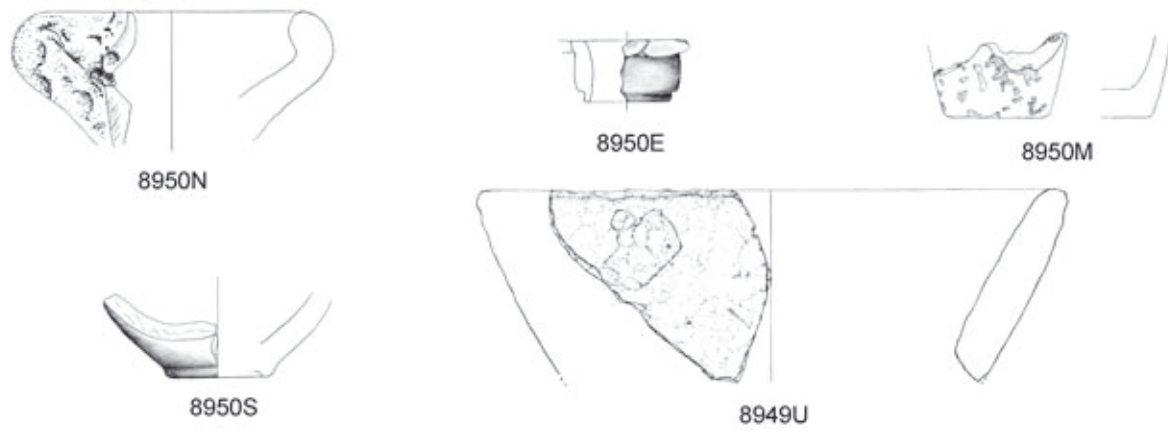

Gefäße aus Calcitalabaster



Abb. T131 Steingefäße



Abb. T132 Steingefäße: photographische Dokumentation

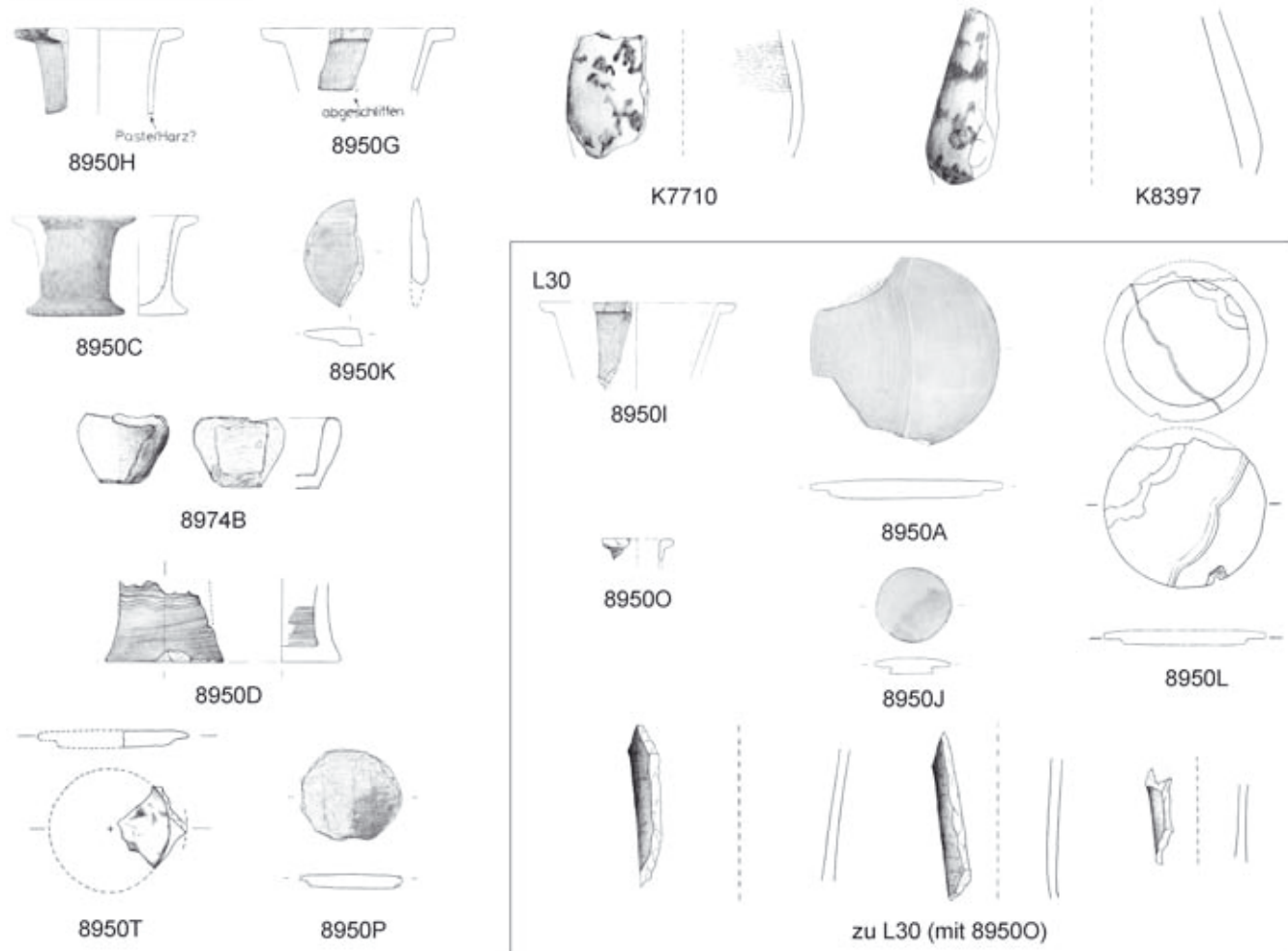

a) Fundstellen von Steingefäßen im Bereich des Tempels.  
 a: L30 mit dem originalen Estrichrest, auf dem die Fragmente von Steingefäßen lagen, die von dem angesetzten Mäuerchen überbaut wurden; b: L25 (8974B); c: L31 (8950D); d: L37 (8950T); e: L29 (8950P)

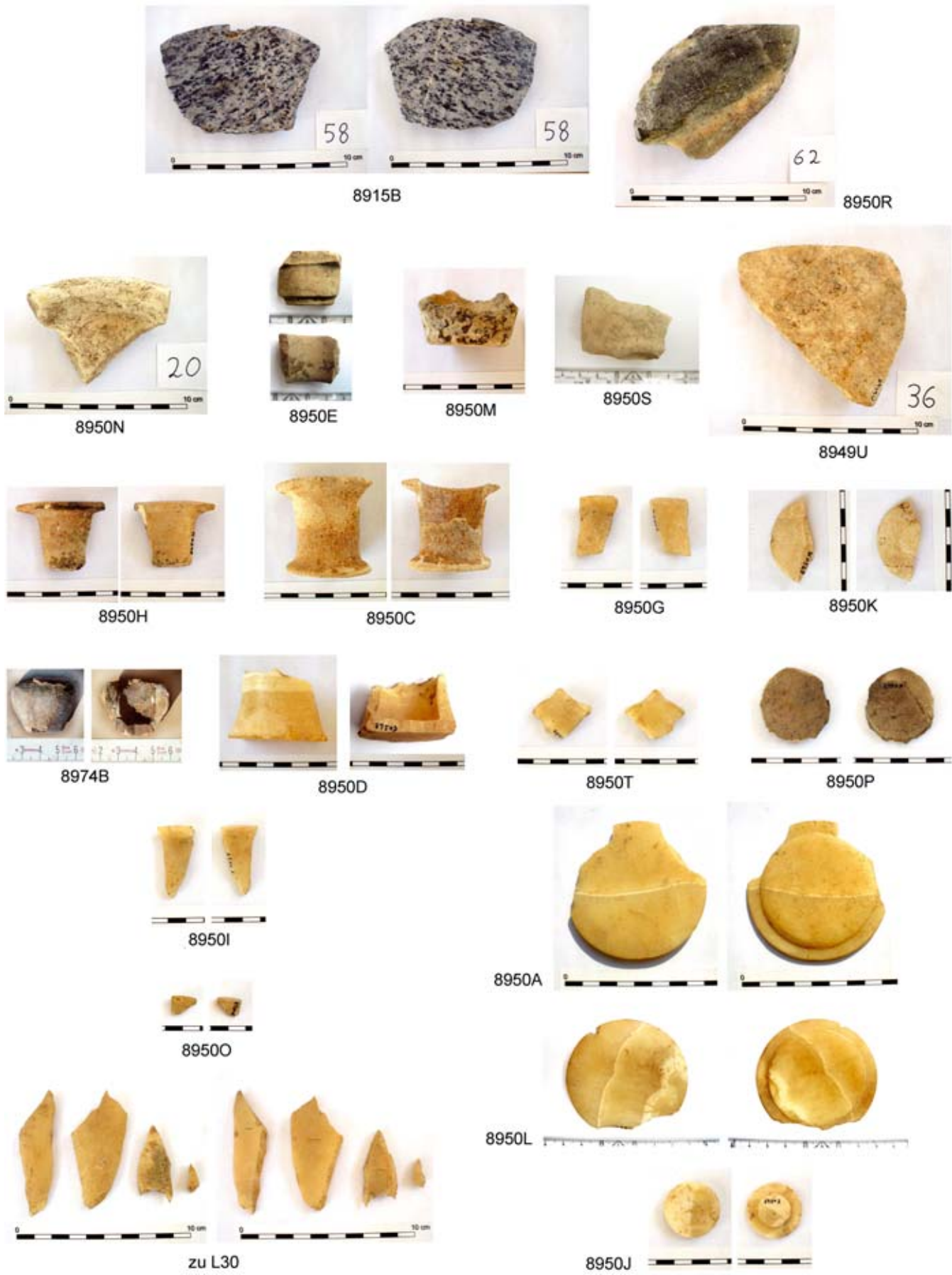
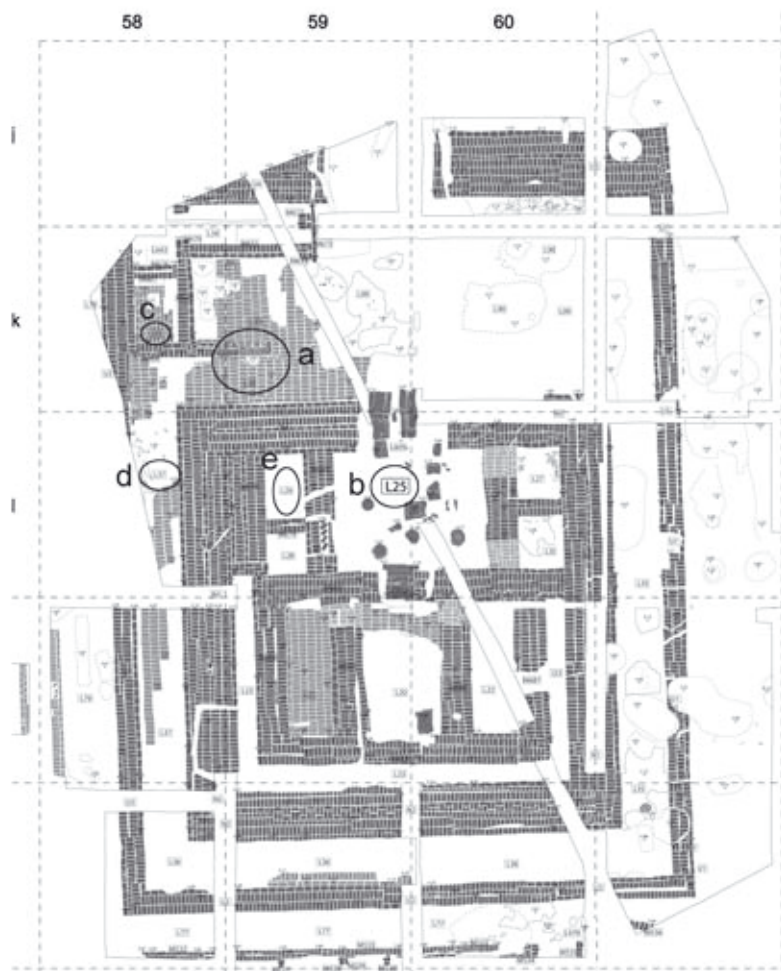
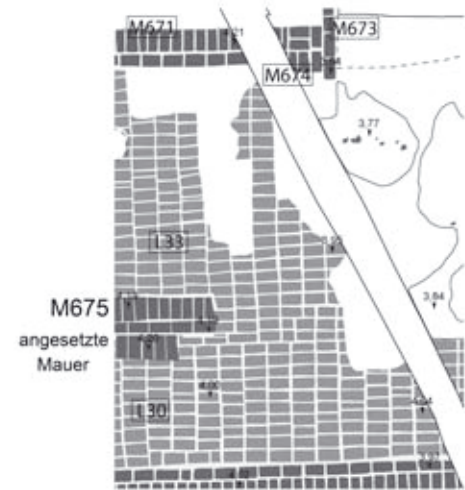

b) M675 mit angesetztem Mäuerchen



c) M675 mit angesetztem Mäuerchen

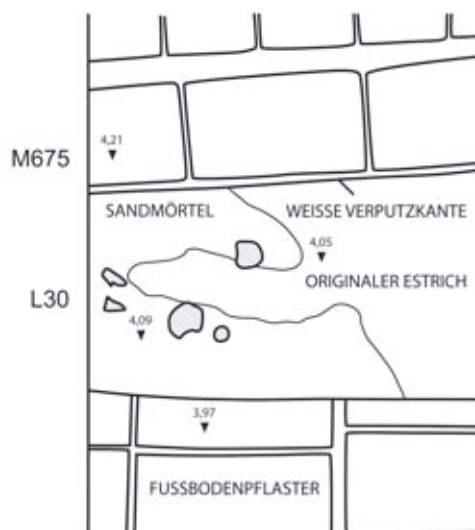

d) L30 nach Entfernen des angesetzten Mäuerchens mit den Fragmenten von Schminckgefäßen



e) L30 nach Entfernen des angesetzten Mäuerchens mit den Fragmenten von Schminckgefäßen

Abb. T133 Steingefäße: Fundsituation

Mörser



Haus V, m/61, Pl. 7, L556, Gru. 9 mit Mörserfragment, str. e/3



Abb. T134 Mörser; photographische Dokumentation



Die "Backstube" in n/62, Pl.1, Sit. 2; str. b/1

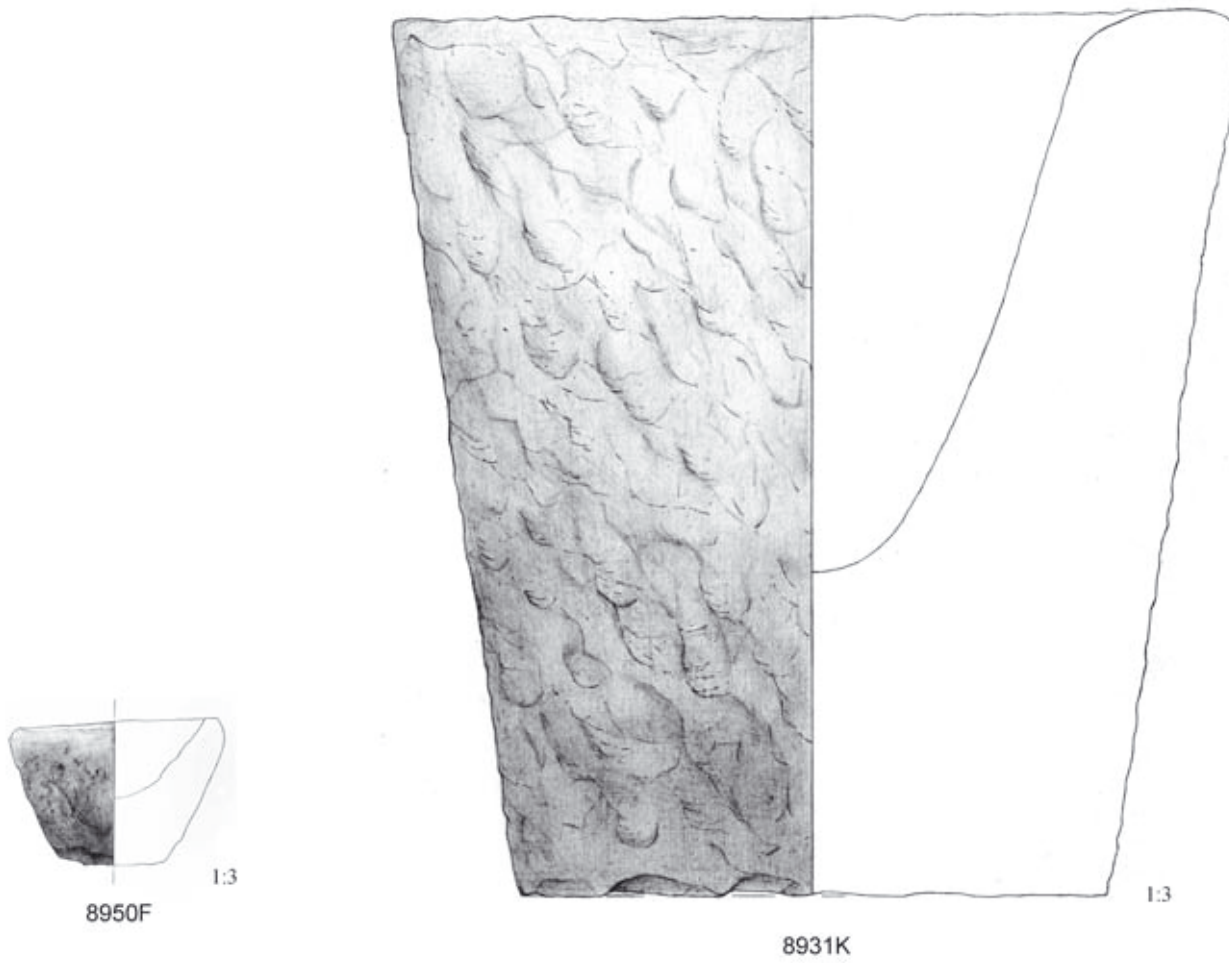
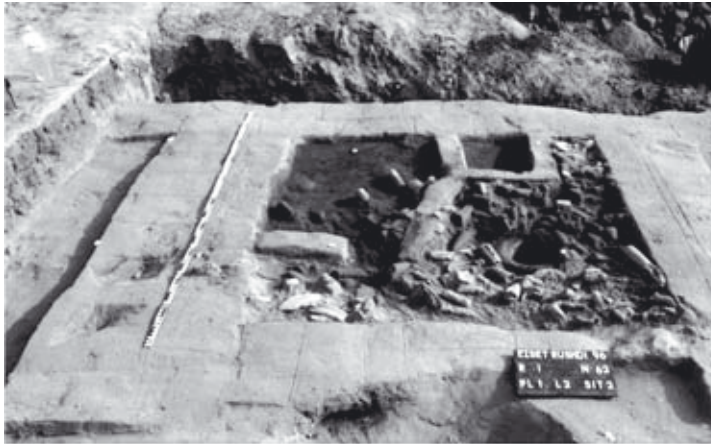
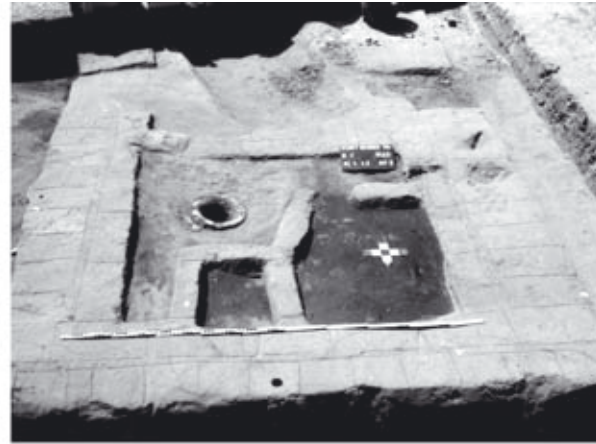

Die "Backstube" in n/62, Pl.1, Sit. 3  
(nach Entfernen der Brotformen); str. b/1

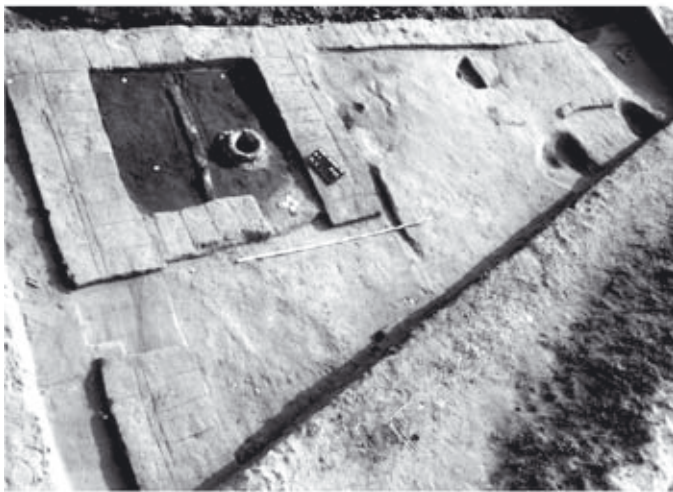

Die "Backstube" in n/62, Pl. 2; str. b/2



Die "Backstube" in n/62, Pl. 3; str. c



a)



b)



c)



d)

a) - c) 8931K

d) 8950F

Abb. T135 Mörser, photographische Dokumentation, Fundsituation



Paletten



Kleine Reibsteine/Stößel oder Spielsteine



Abb. T136 Paletten, Kleine Reibsteine, Stößel oder Spielsteine

Spinnwirtel

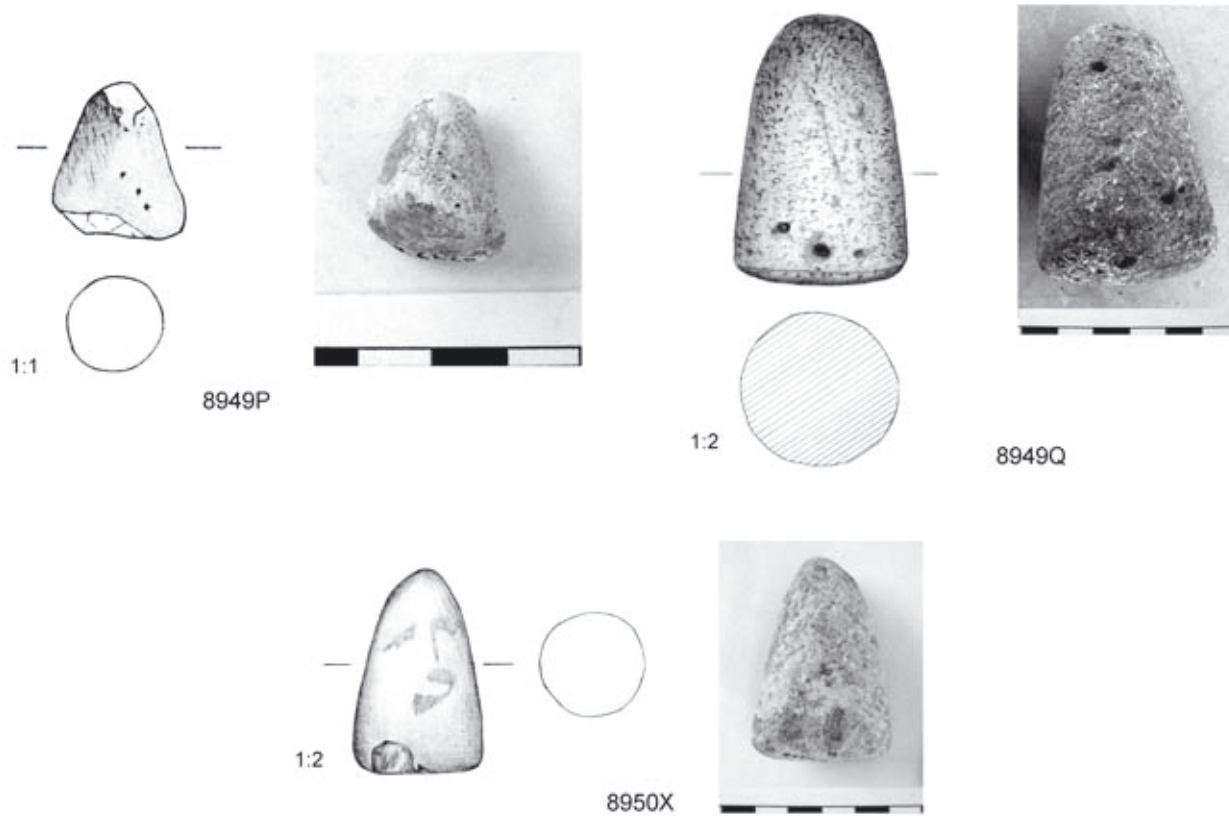
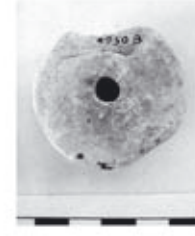
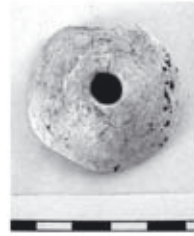
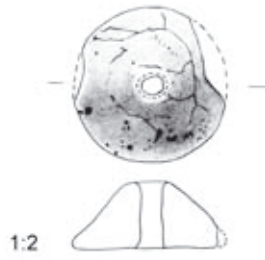

8950B

Bohrerkappen (?)



8975F/h

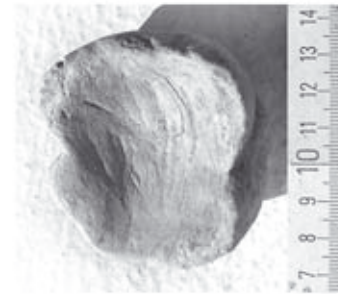

8976G

Kalkstein mit Abrasionen

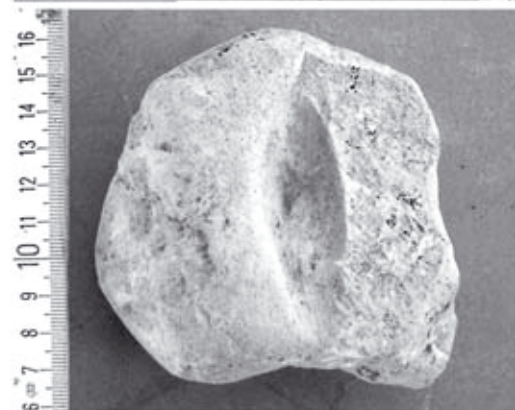
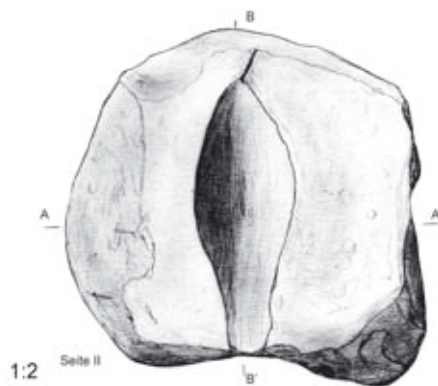
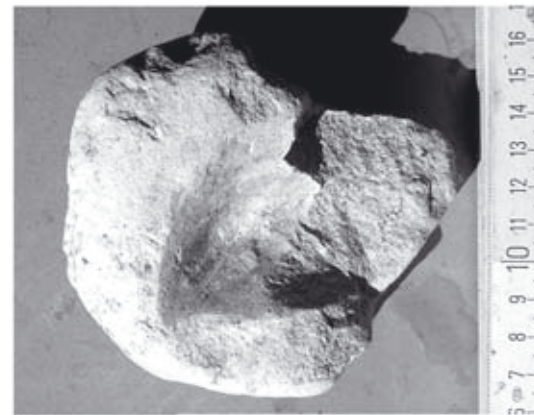
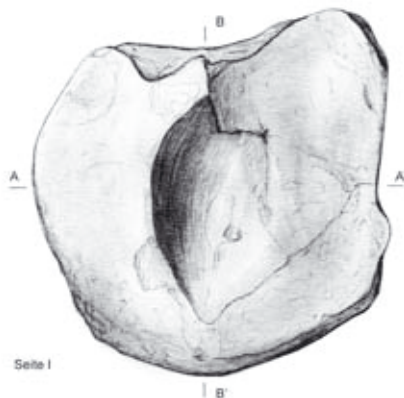

8975N

Abb. T137 Spinnwirtel, Bohrer-kappen (?), Kalkstein mit Abrasionen

Netzsenker und Webstuhlgewichte

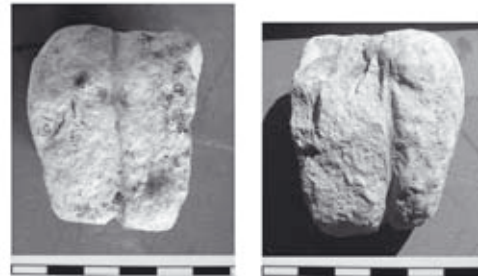
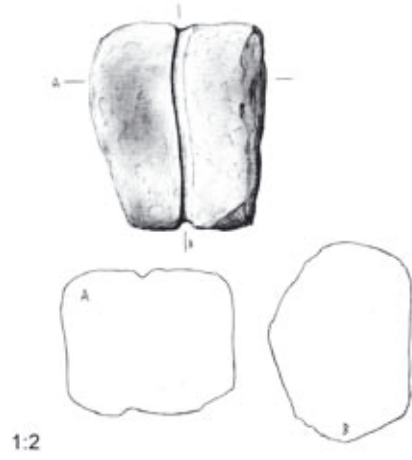

8974A

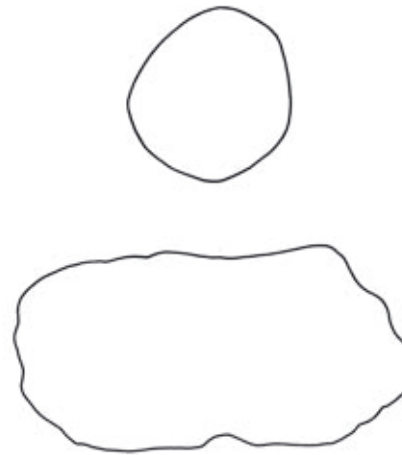
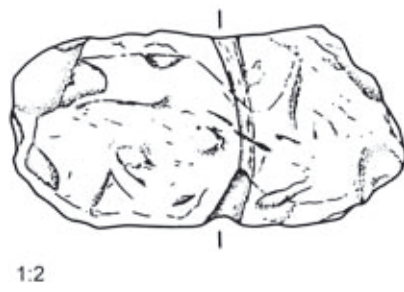

zu K8248

Ringständer aus Stein



K7855

Abb. T138 Netzsenker und Webstuhlgewichte, Ringständer aus Stein

Opfertafeln

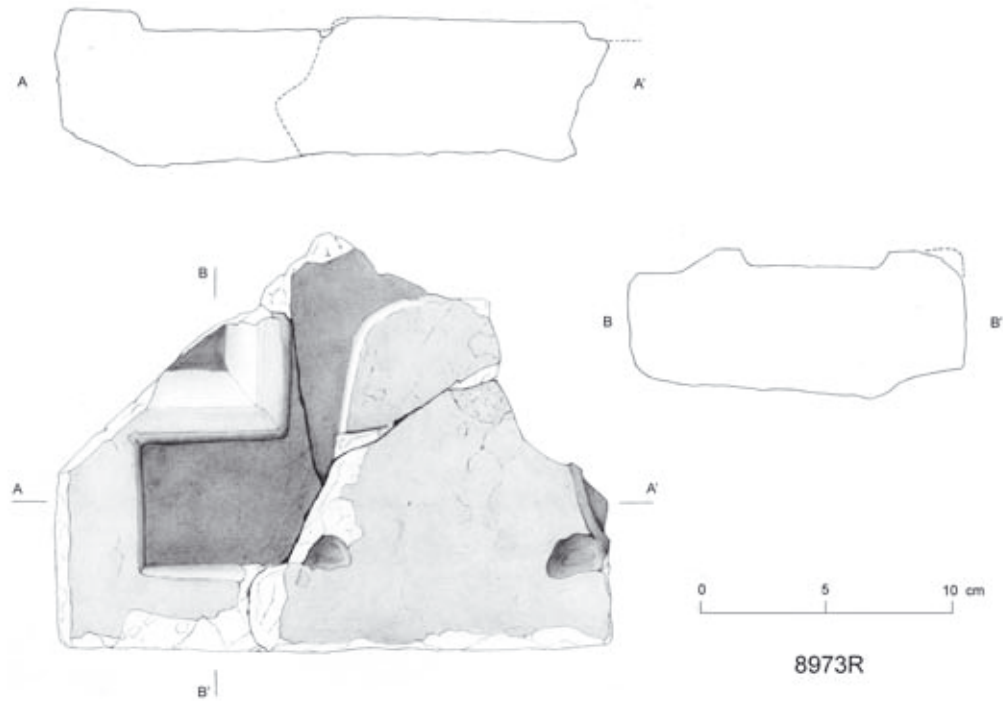

8973R

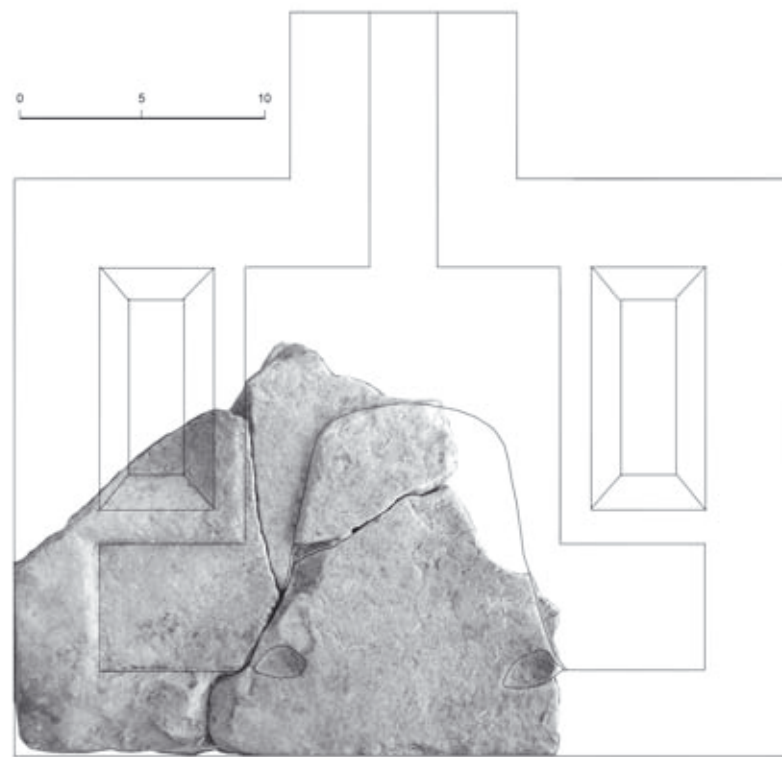

8973R (Rekonstruktion)

Abb. T139 Opfertafeln

Opfertafeln (f.)

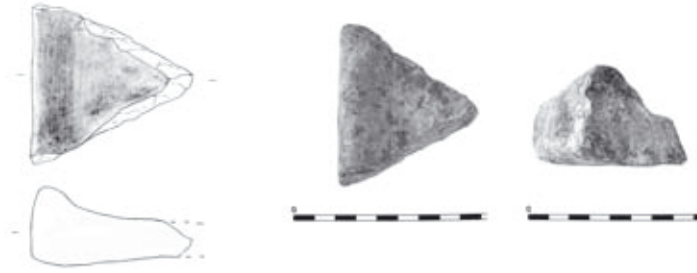

8950Q

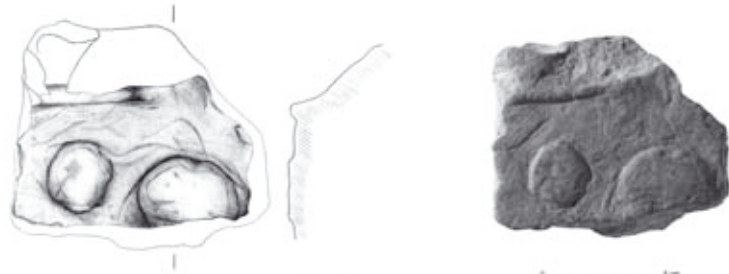

8973T



1:3

8973X

Abb. T140 Opfertafeln

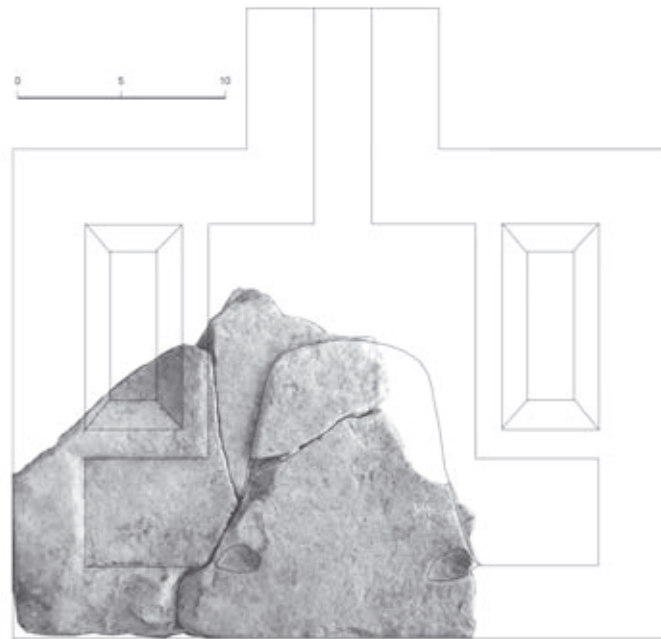

8973R

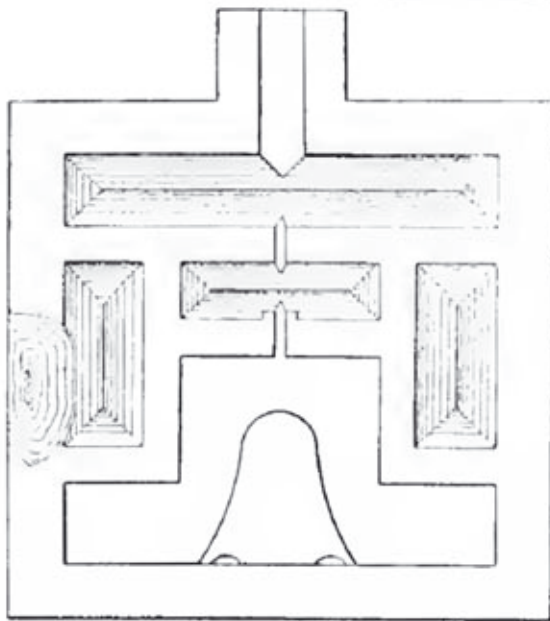

CG 23068

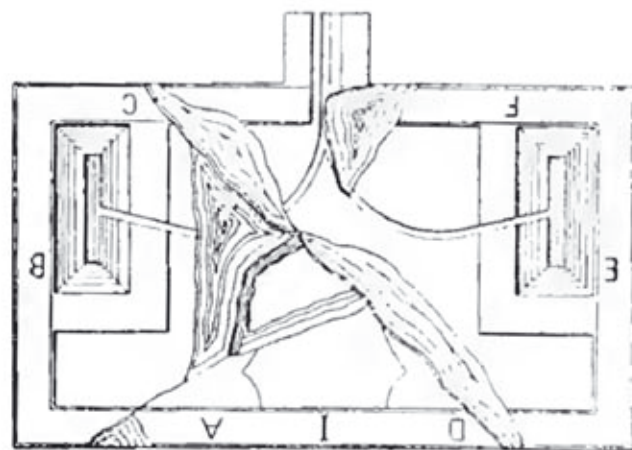

CG 23049



BM EA 990

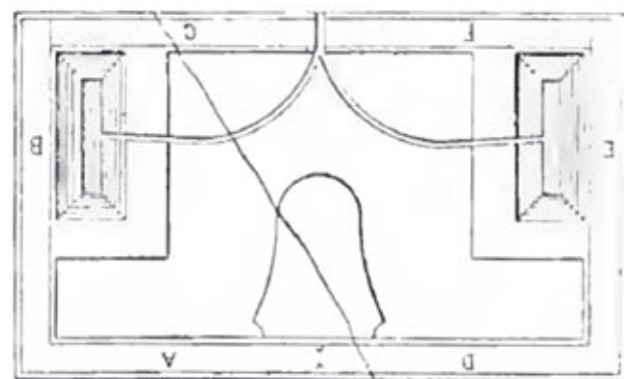

CG 23050

Ohne einheitlichen Maßstab

Abb. T141 Opfertafel 8973R, Vergleichsstücke

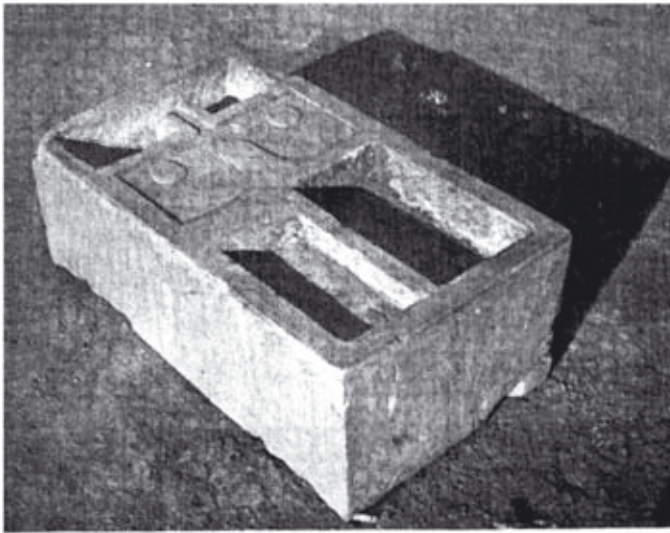

A.—A limestone offering table found in the Hypostyle Hall of the temple.

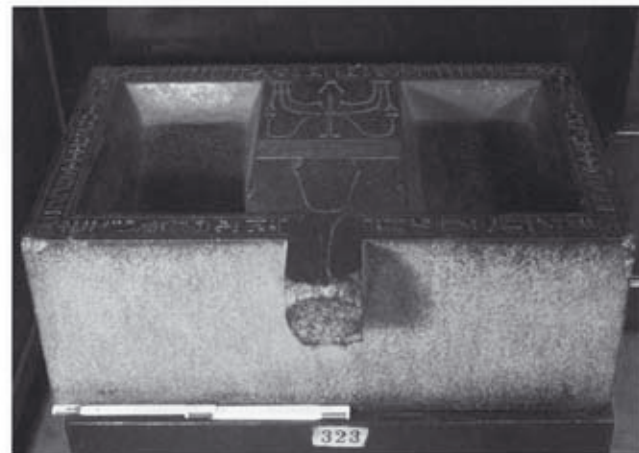

Altar Amenemhats II. aus Dilamun oder Khata'na (Kat. 5)



B.—The alabaster offering table found in the house east of the temple.

Opfertafeln aus Ezbet Ruschdi (Grabung Sh. Adam 1952),  
ASAE 56, Pl. 14.



C. Tell el-Dab'a (1). Fragment eines Altars Sesostris' III.  
(Kat. 7)

Ältere Opfertafelfunde aus dem Raum  
Tell el-Dab'a, TD I, Kat. 5; Kat. 7

Türangelsteine



Abb. T143 Türangelsteine; photographische Dokumentation





Abb. T144 Türangelsteine; photographische Dokumentation

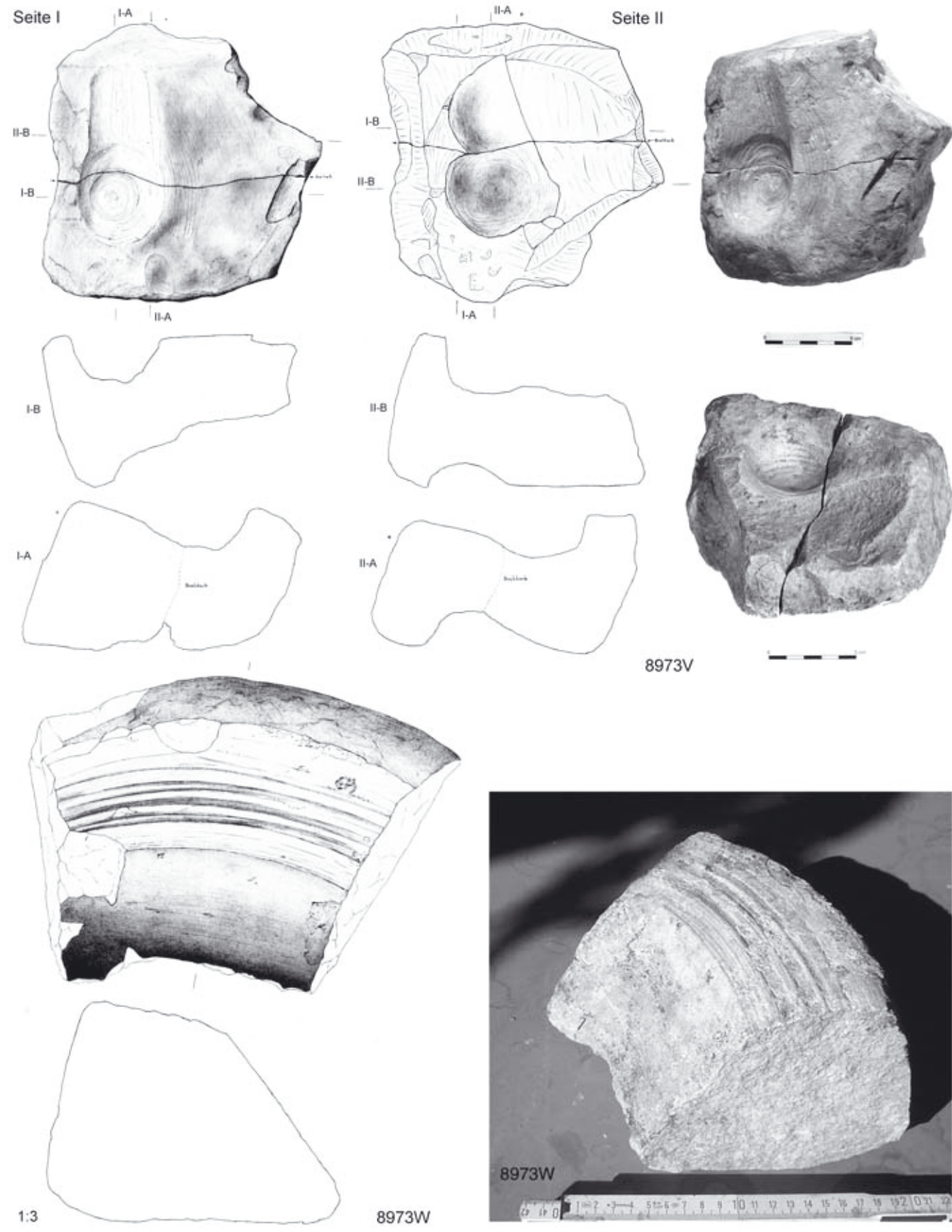

1) R/I-k/58-59, Pl. 10, Detail: M27, M23, M25 mit Türdurchgängen und Türangelsteinen in situ (str. e/3)

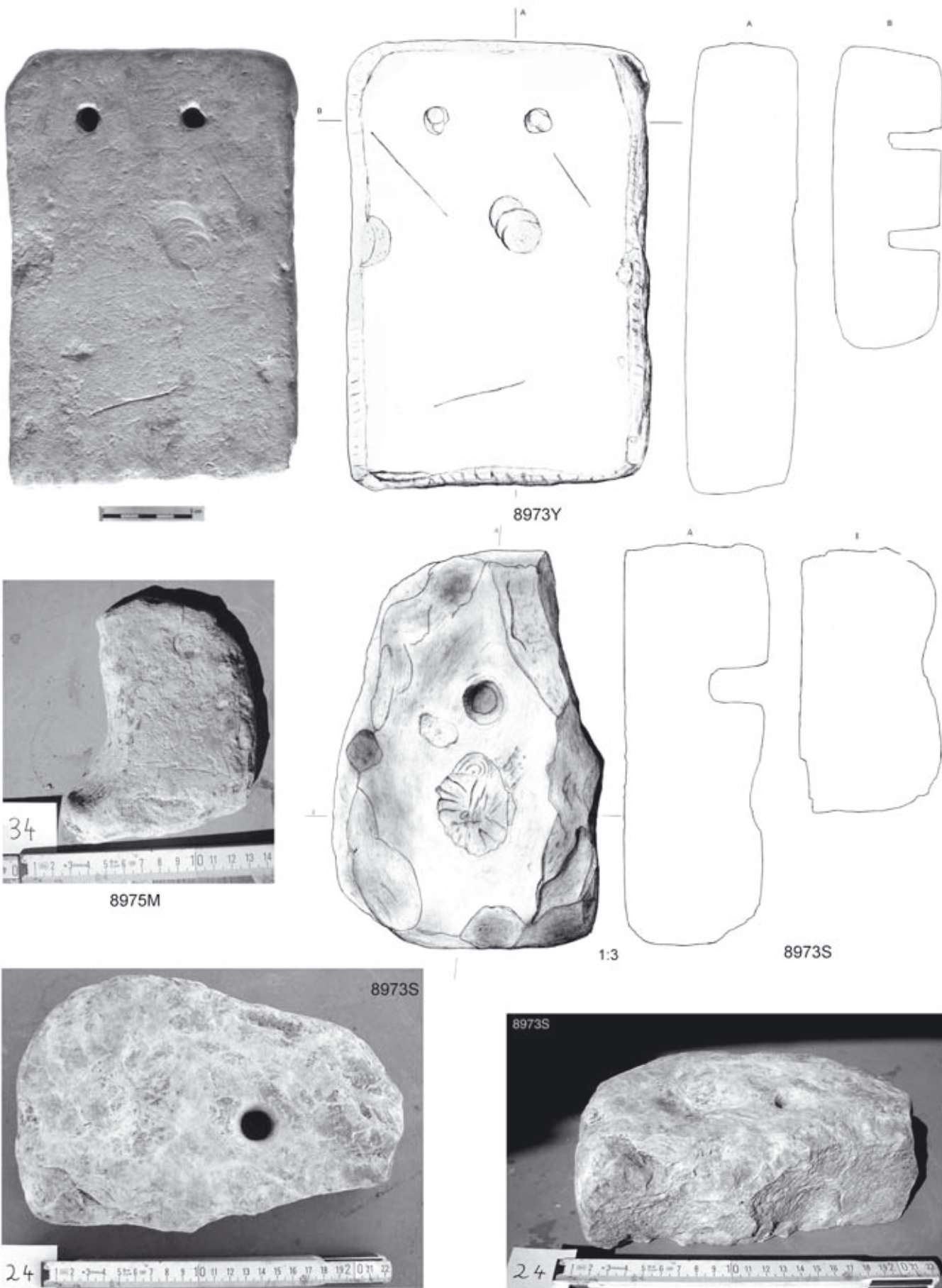
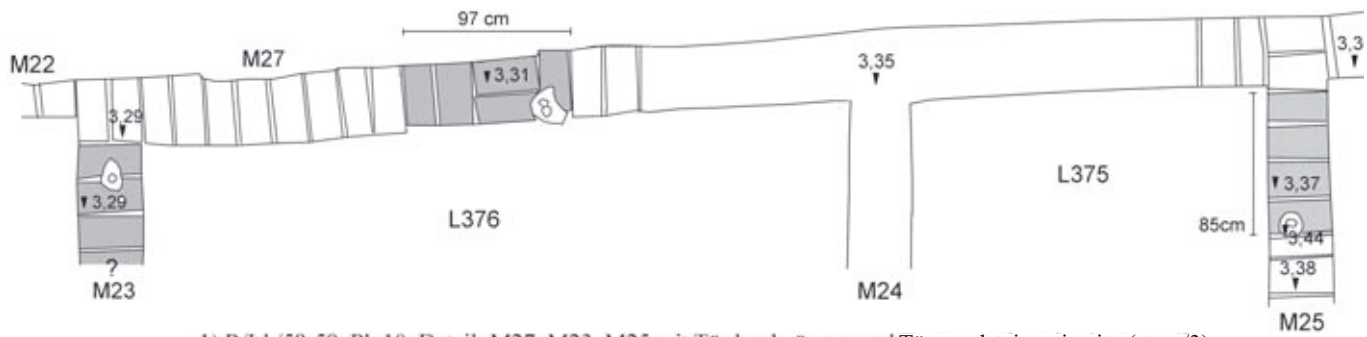
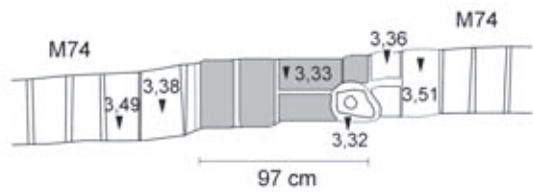

2) R/I-k/58-59, Pl. 9, Detail: M74 mit weiterverwendetem Türdurchgang von M27 mit Türangelstein in situ (str. c/2)

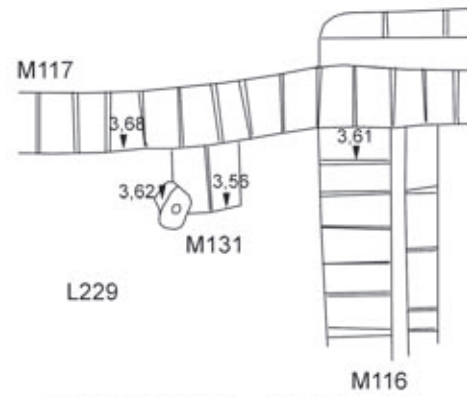

3) R/I-k/59, Pl. 8, Detail: M131 mit Türangelstein (in situ?; vgl. M25; str. e/1)

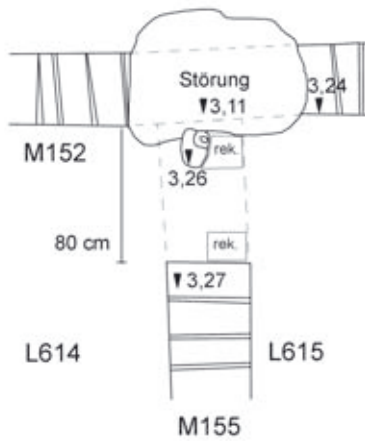

4) R/I-l/61, Pl. 4, Detail: M155 mit Türdurchgang und Türangelstein in situ (str. e/4)



5) R/I-m/61, Pl. 4, Detail: M319 mit Türdurchgang und Türangelstein in situ (str. e/1)



6) R/I-n/59, Pl. 7, Detail: M371 mit Türdurchgang und Türangelstein in situ (str. e/3)

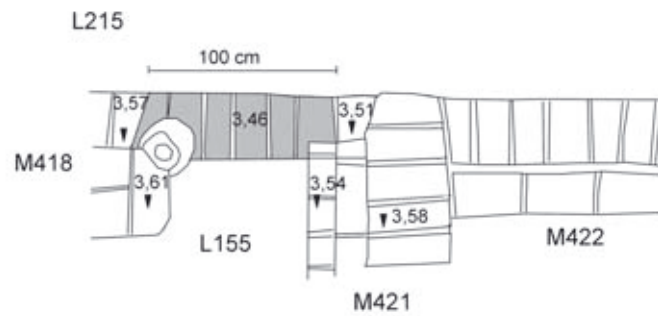

7) R/I-n/59, Pl. 4, Detail: M418 mit Türdurchgang und Türangelstein in situ (str. e/1)

Abb. T145 Türangelsteine: Fundsituation

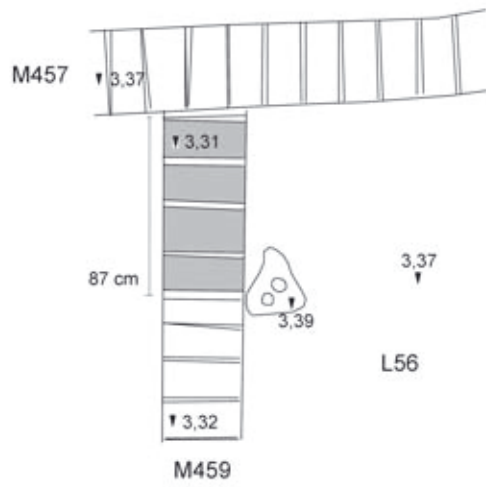

8) R/I-n/61, Pl. 6, Detail: M459 mit Türdurchgang und Türangelstein in situ (str. e/3)



10) R/I-o/59, Pl. 1, Detail: M563 mit Türdurchgang und Türangelstein 8973S in situ (str. b-c)

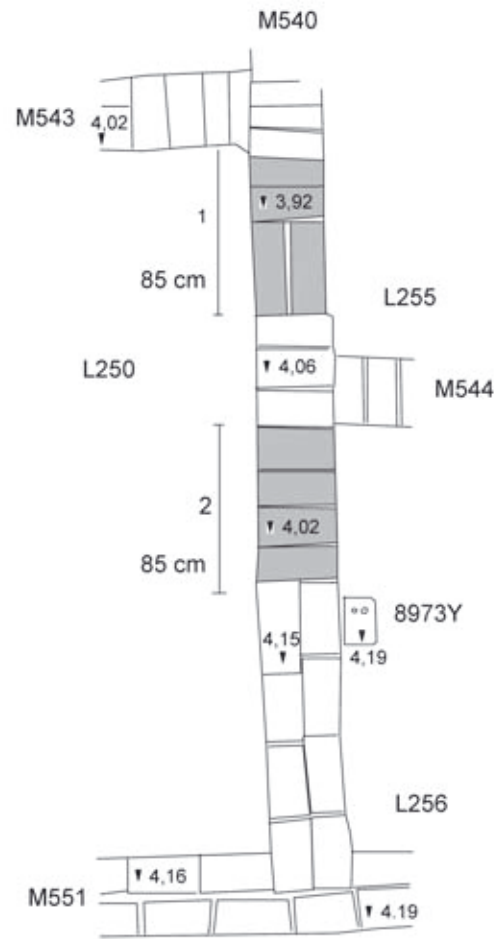

9) R/I-o/59, Pl. 3, Detail: M540 mit Türdurchgang 1 (ohne Türangelstein) und Türdurchgang 2 mit Türangelstein 8973Y in situ (str. c)

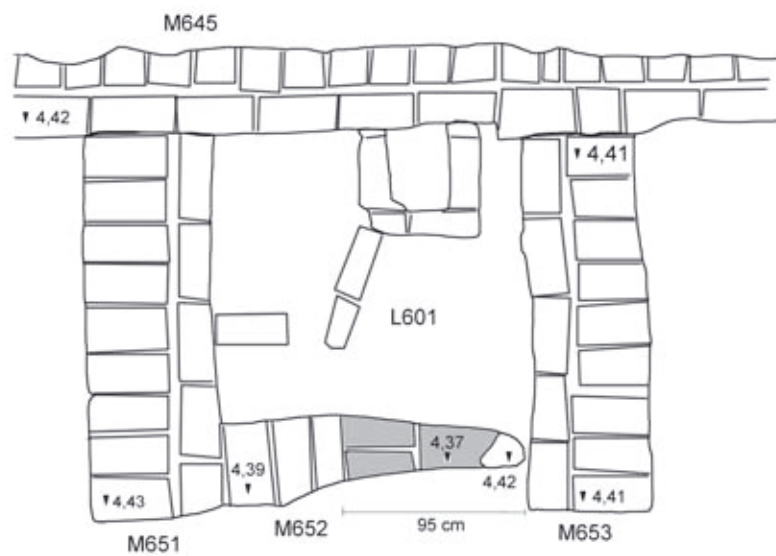

11) R/I-n/62, Pl. 1, Detail: M652 mit Türdurchgang und Türangelstein (?) in situ (str. b/1)

Abb. T146 Türangelsteine: Fundsituation

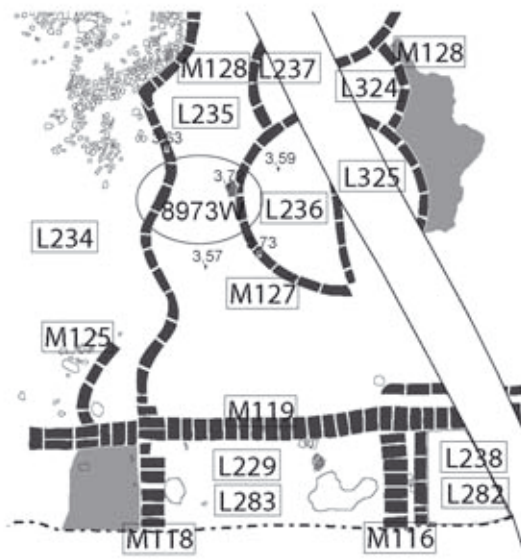

a) R/I-k/59, Pl. 7, Detail: Lage der Drehpfanne 8973W im Speicherhof L.235 (str. c/1)

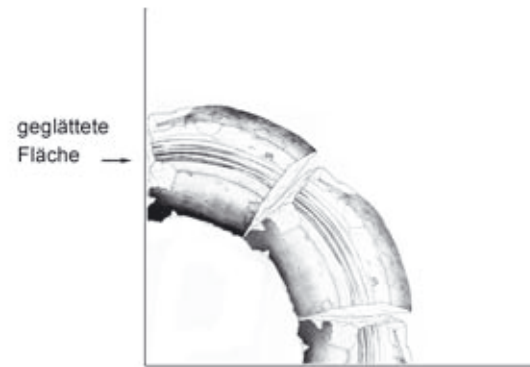

1)

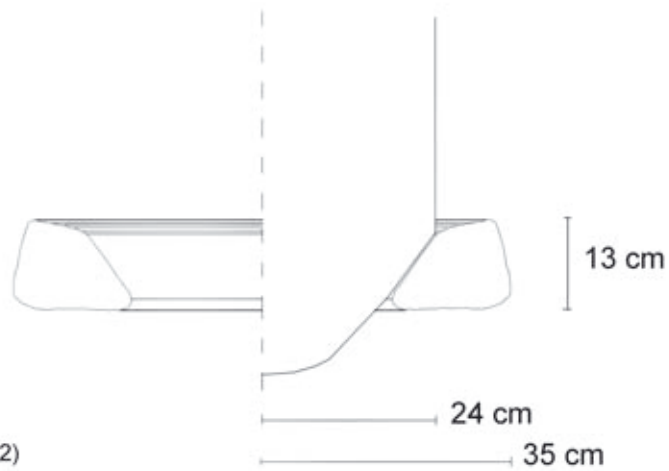

2)

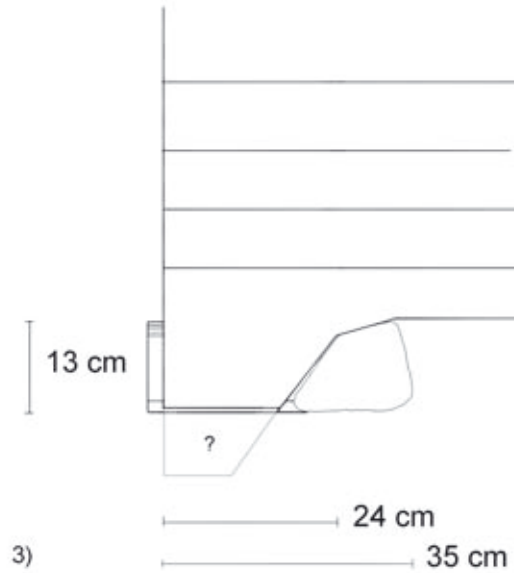

3)

b) 8973W: 1) schematische Ergänzung; 2) mit runder Angel; 3) als Viertelkreis, mit dreieckig zugespitzter Angel.

Abb. T147 Drehpfanne 8973W: Fundsituation und Ergänzungsvorschläge

Unterlagsplatte (Zir-Standplatz)

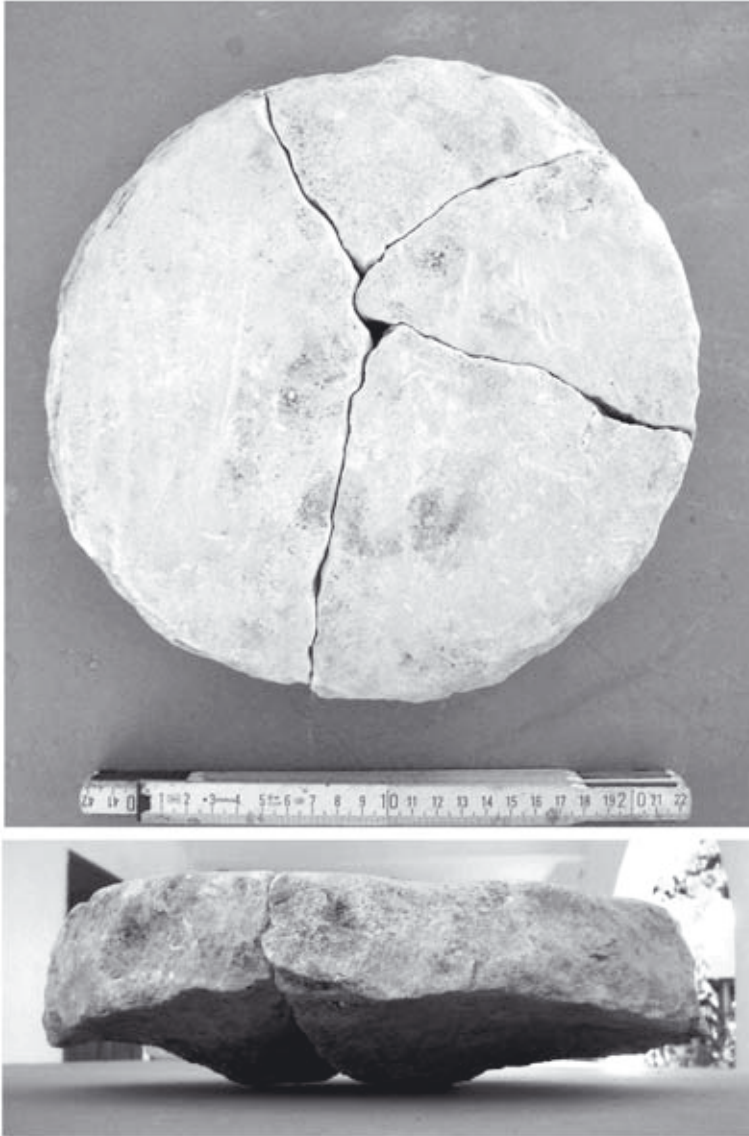

8973Z

Lampe aus Kalkstein ?

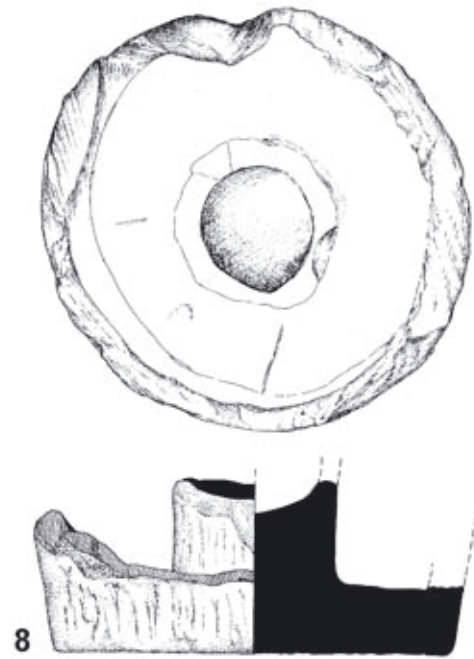

Ezbet Ruschdi (4768)  
MR oder 2. Zzt.  
(nach V. MÜLLER, in *Timelines II*, 261)

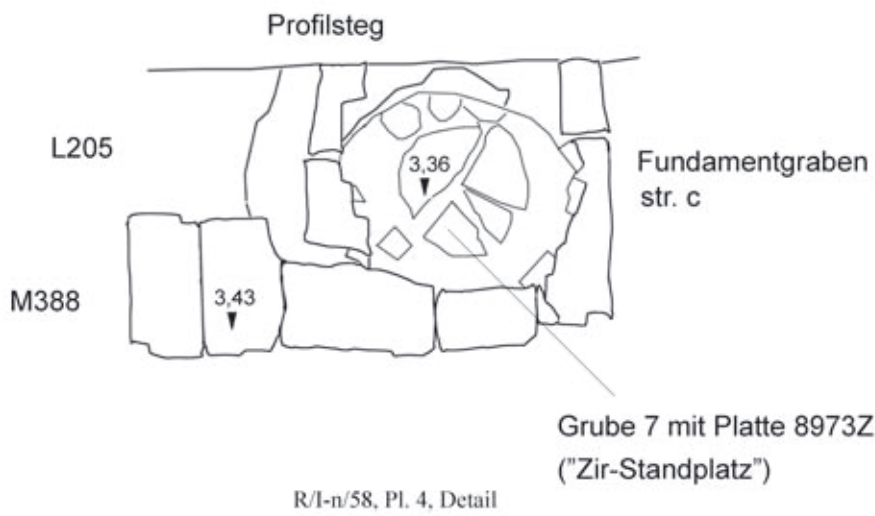

Architekturteil (Rundstab?)

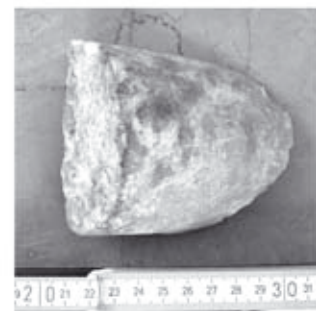

8976K

Abb. T148 Unterlagsplatte (Zir-Standplatz), Lampe?, Architekturteil (Rundstab?); photographische Dokumentation

Skarabäen, Siegel und Siegelabdrücke



Abb. T149 Skarabäen und Siegel; photographische Dokumentation

Skarabäen, Siegel und Siegelabdrücke (f.)

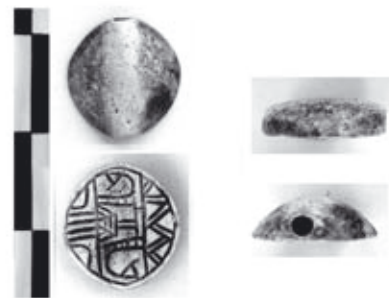
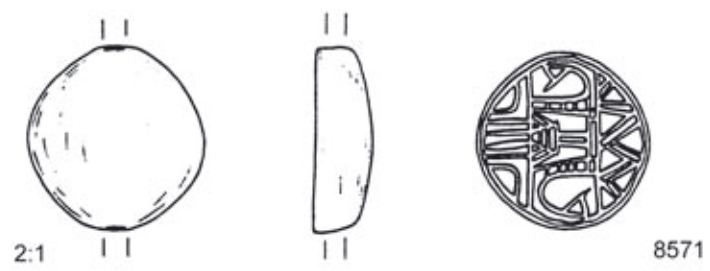

Abb. T150 Skarabäen, Siegel und Siegelabdrücke; photographische Dokumentation

Anhänger und Amulette





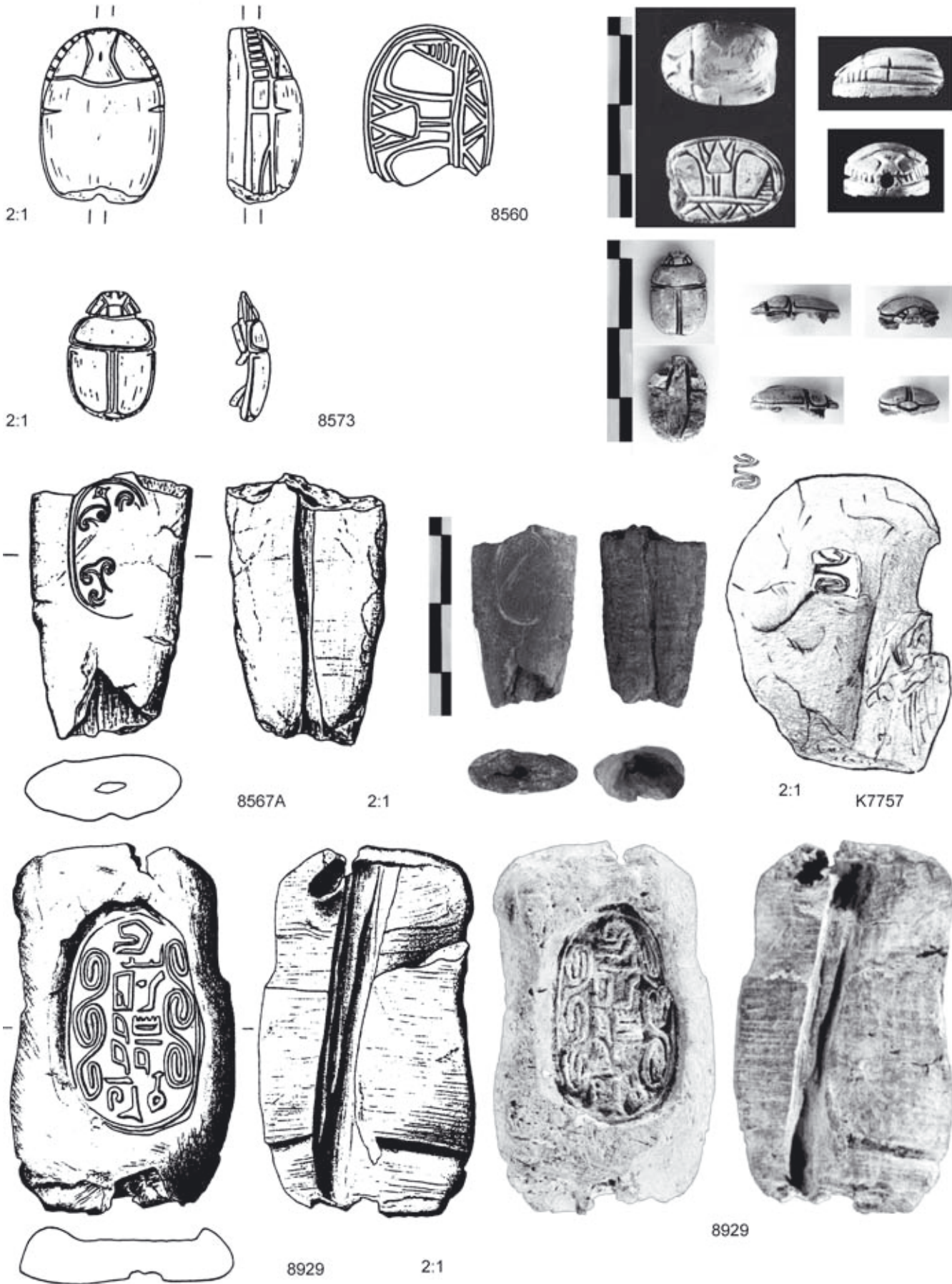





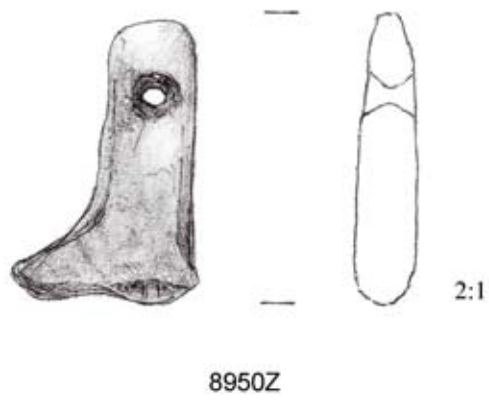
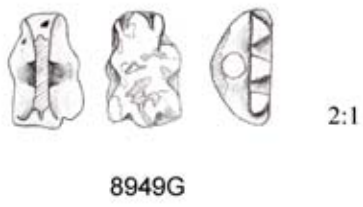
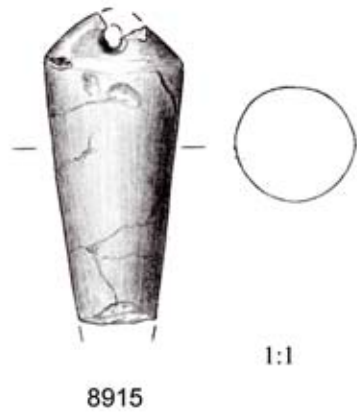















Abb. T151 Anhänger und Amulette; photographische Dokumentation



Perlen

1 =  = graue Flecken	9 =  =	17 =  =
2 =  = hellgrau gefleckt	10 =  =	18 =  =
3 =  = Reste grüner Glasur mit Flecken	11 =  =	19 =  =
4 =  =	12 =  = Reste grüner Glasur	20 =  =
5 =  = grüne Glasur	13 =  =	21 =  =
6 =  =	14 =  =	22 =  = zerbrochen
7 =  =	15 =  = Reste grüner Glasur	23 =  =
8 =  =	16 =  = Reste grüner Glasur	8949J



Abb. T152 Perlen; photographische Dokumentation

Metall-Nadeln (Kupferlegierung)



Metall-Messer (Kupferlegierung)

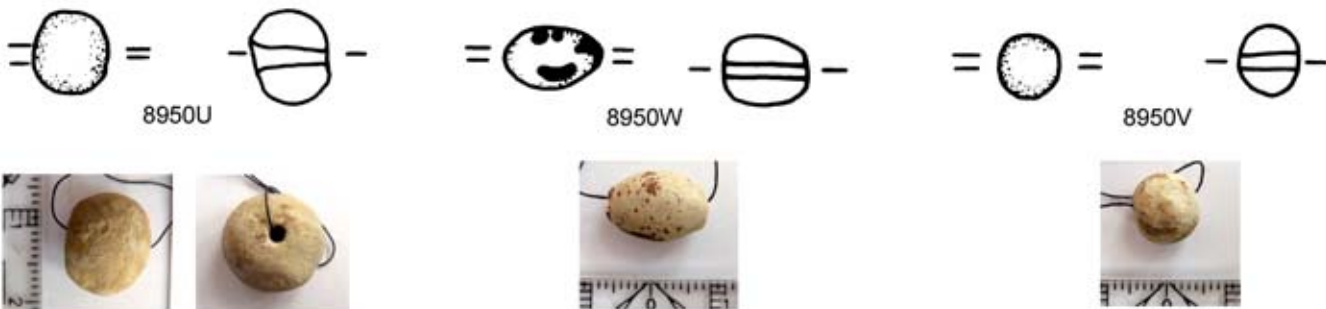
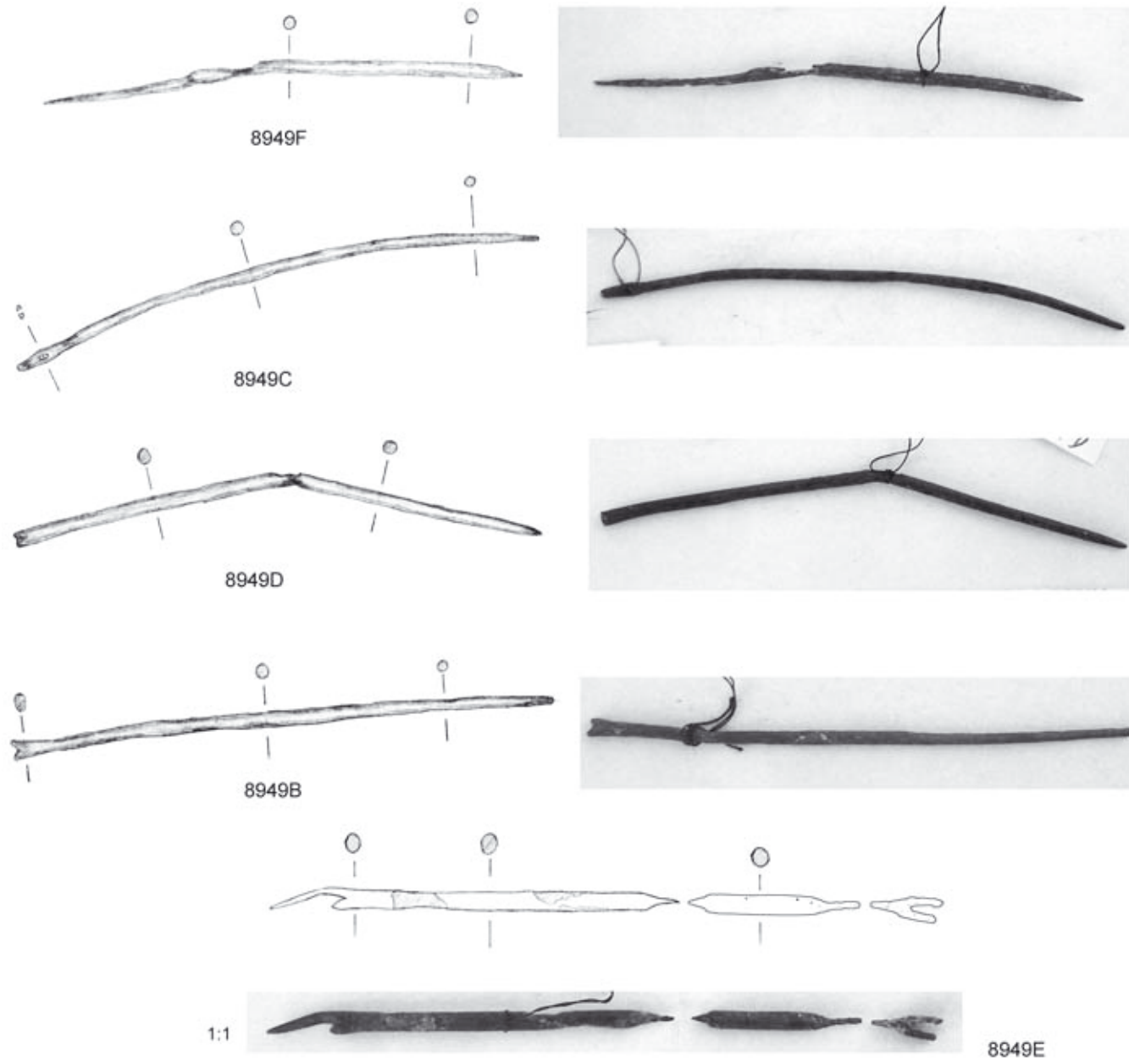

Abb. T153 Metall-Nadeln und Metall-Messer (Kupferlegierung); photographische Dokumentation

Knochengeräte/Muscheln/Schnecken



8949N 1:2



8977U 1:2

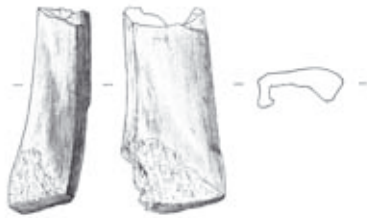

8949O 1:2

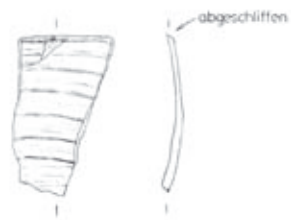

8949R 1:2



K7397

1:1



Abb. T154 Knochengeräte, Muscheln und Schnecken; photographische Dokumentation

Mahlplatten/Mahl-Reibsteine



Abb. T155 Mahlplatten und Mahl-Reibsteine

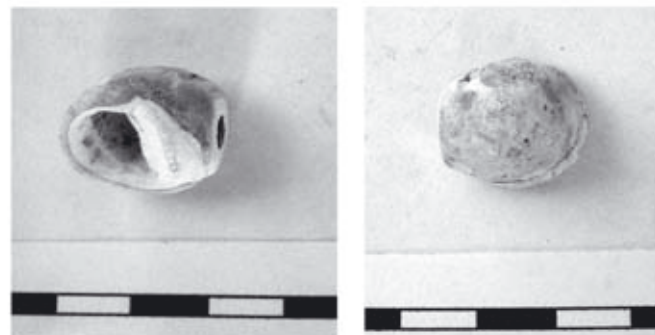

Abb. T156 Mahlplatten und Mahl-Reibsteine

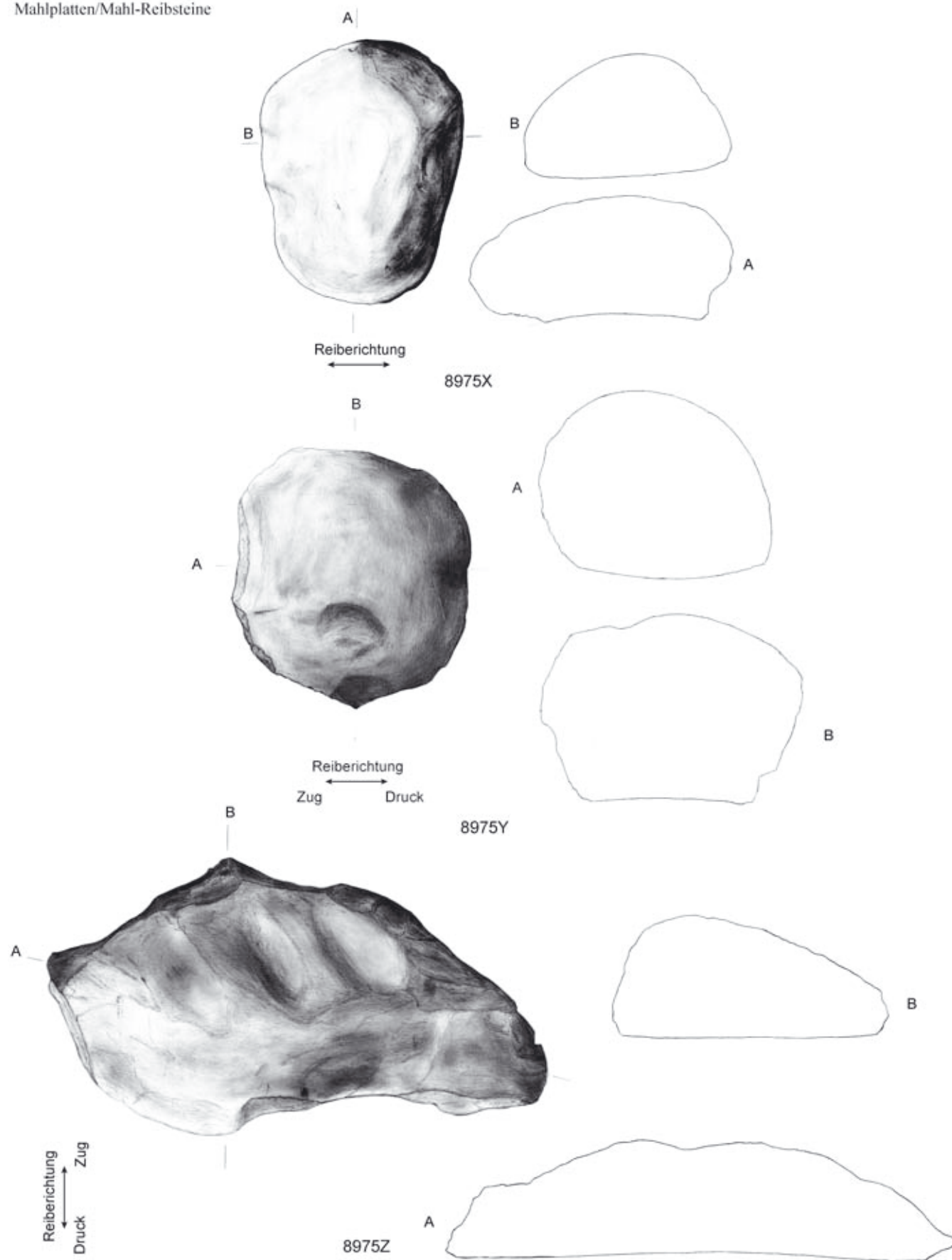

8975X

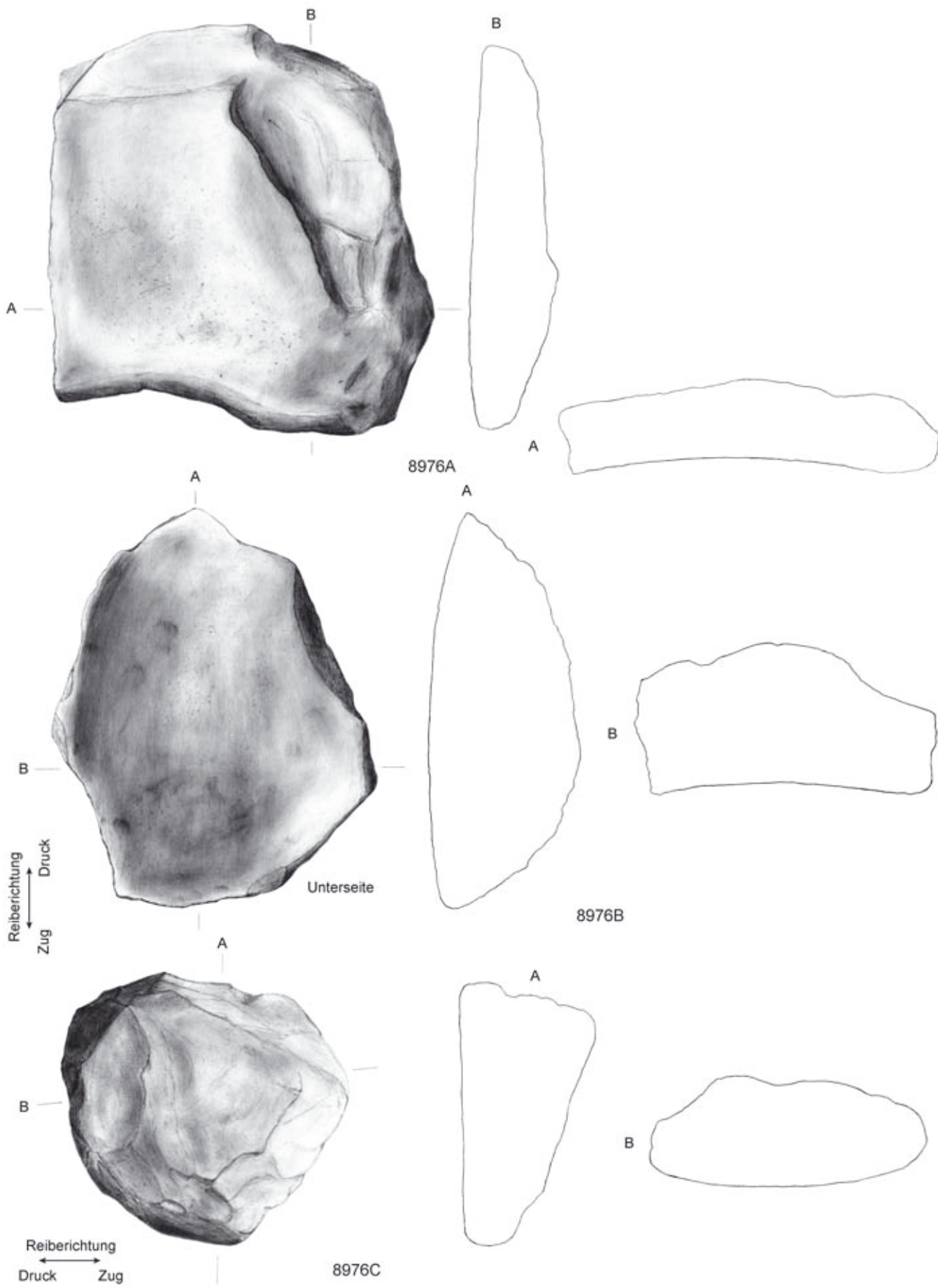
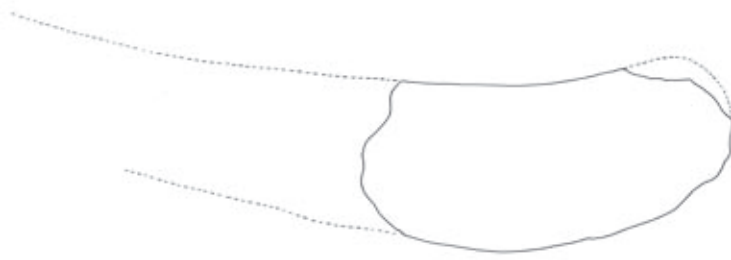
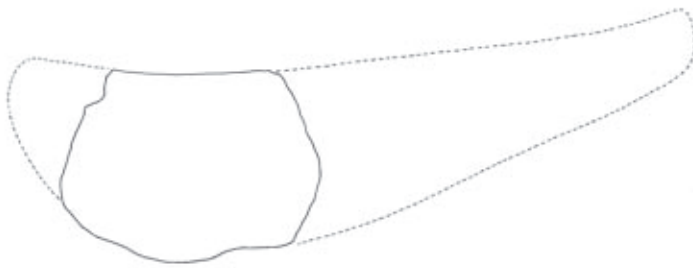
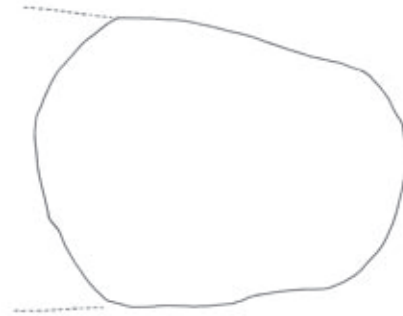

8975Y

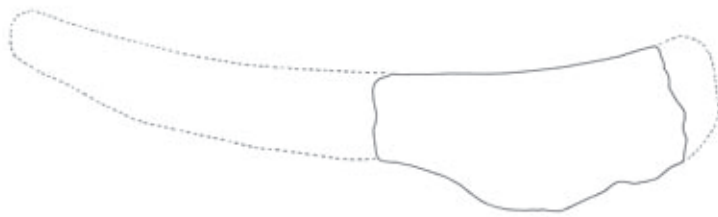
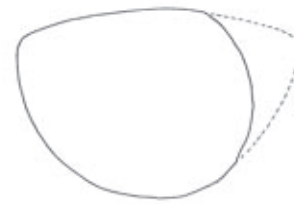

8975B

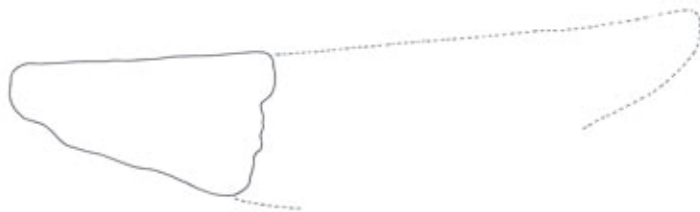

8976C



Abb. T157 Rekonstruktionsvorschläge für Mahlsteine zu Mahlplatten



Abb. T158 Mahlsteine: photographische Dokumentation



8976A



8976B



8976C

Abb. T159 Mahlsteine: photographische Dokumentation



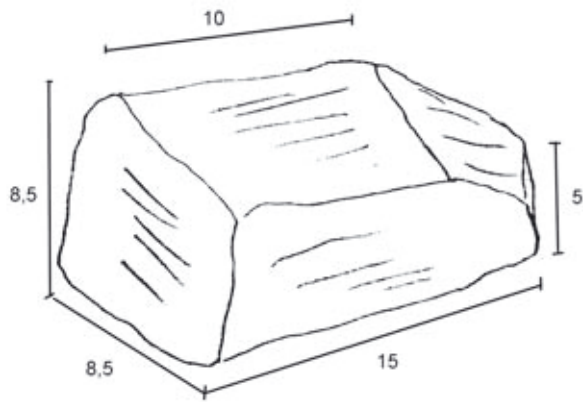

8975L: Skizze, nicht maßstabsgerecht

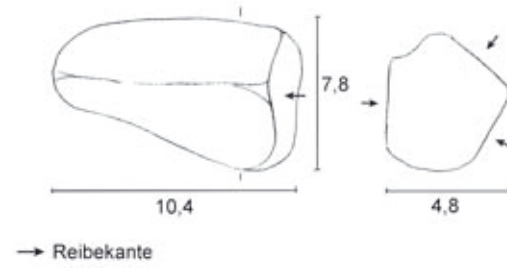

8975O: Skizze, nicht maßstabsgerecht

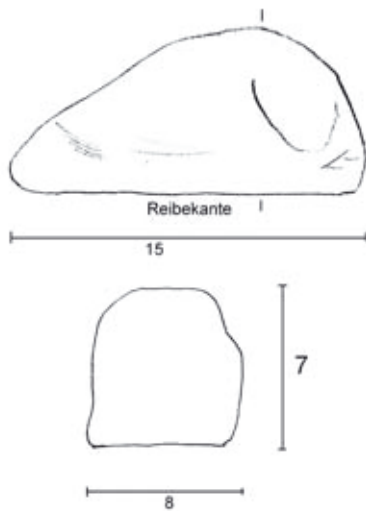

8975Q: Skizze, nicht maßstabsgerecht

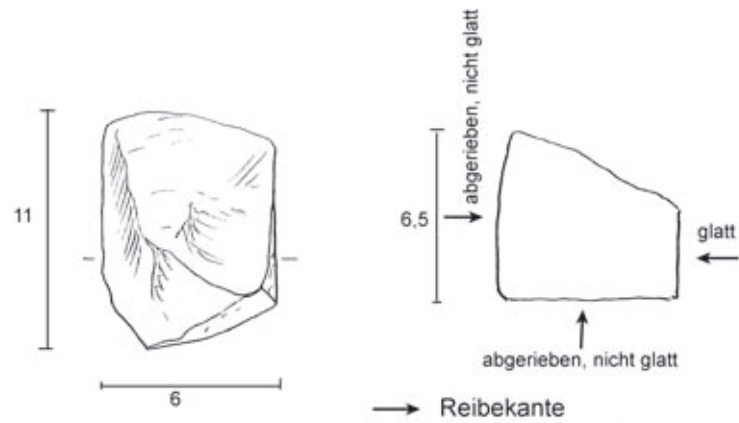

8975R: Skizze, nicht maßstabsgerecht

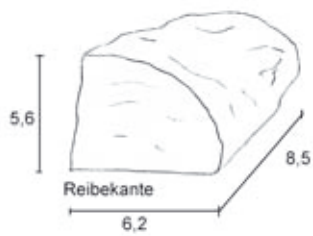

8975S: Skizze, nicht maßstabsgerecht



8975T/a: Skizze, nicht maßstabsgerecht

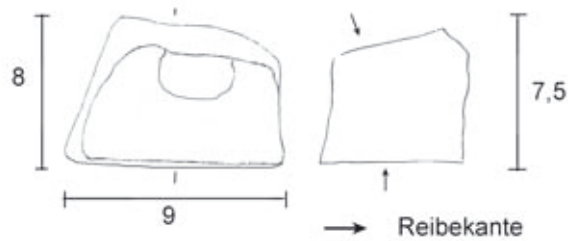

8975T/b: Skizze, nicht maßstabsgerecht

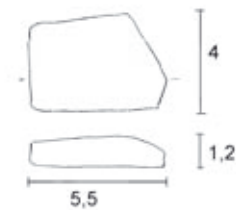

8975T/c: Skizze, nicht maßstabsgerecht



8975T/d: Skizze, nicht maßstabsgerecht

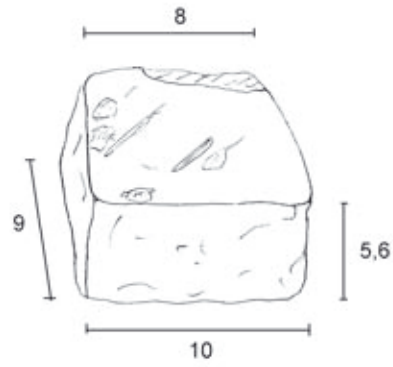

8976F/a: Skizze, nicht maßstabsgerecht

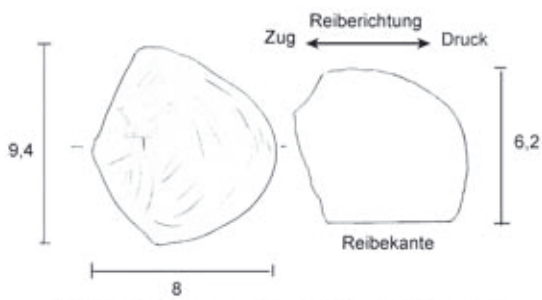

8976F/b: Skizze, nicht maßstabsgerecht



8976F/c: Skizze, nicht maßstabsgerecht



8976F/d: Skizze, nicht maßstabsgerecht



8976F/e: Skizze, nicht maßstabsgerecht

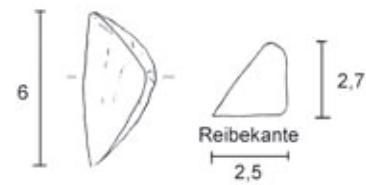

8976F/f: Skizze, nicht maßstabsgerecht



Abb. T161 Reib-, Schleif-, Polier-, Wetz- und Klopffsteine, Hammer



Abb. T162 Reib-, Schleif-, Polier-, Wetz- und Klopfsteine, Hammer

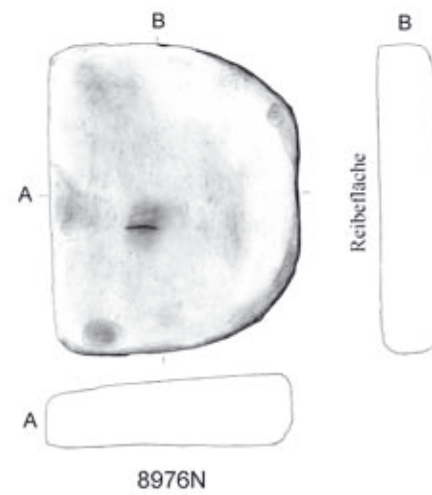
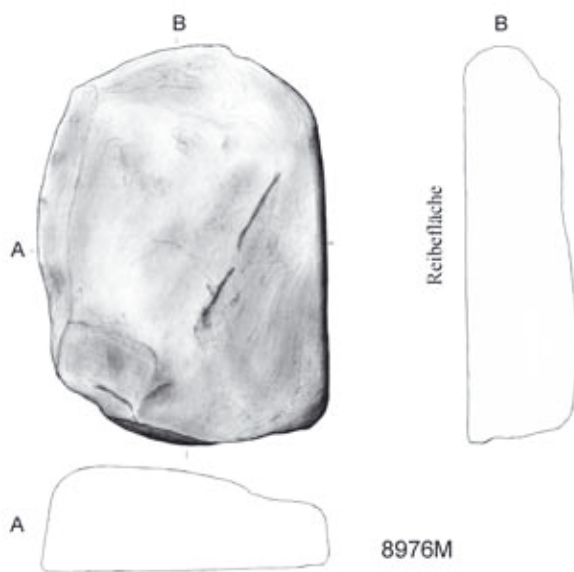

Abb. T163 Reib-, Schleif-, Polier-, Wetz- und Klopffsteine, Hammer

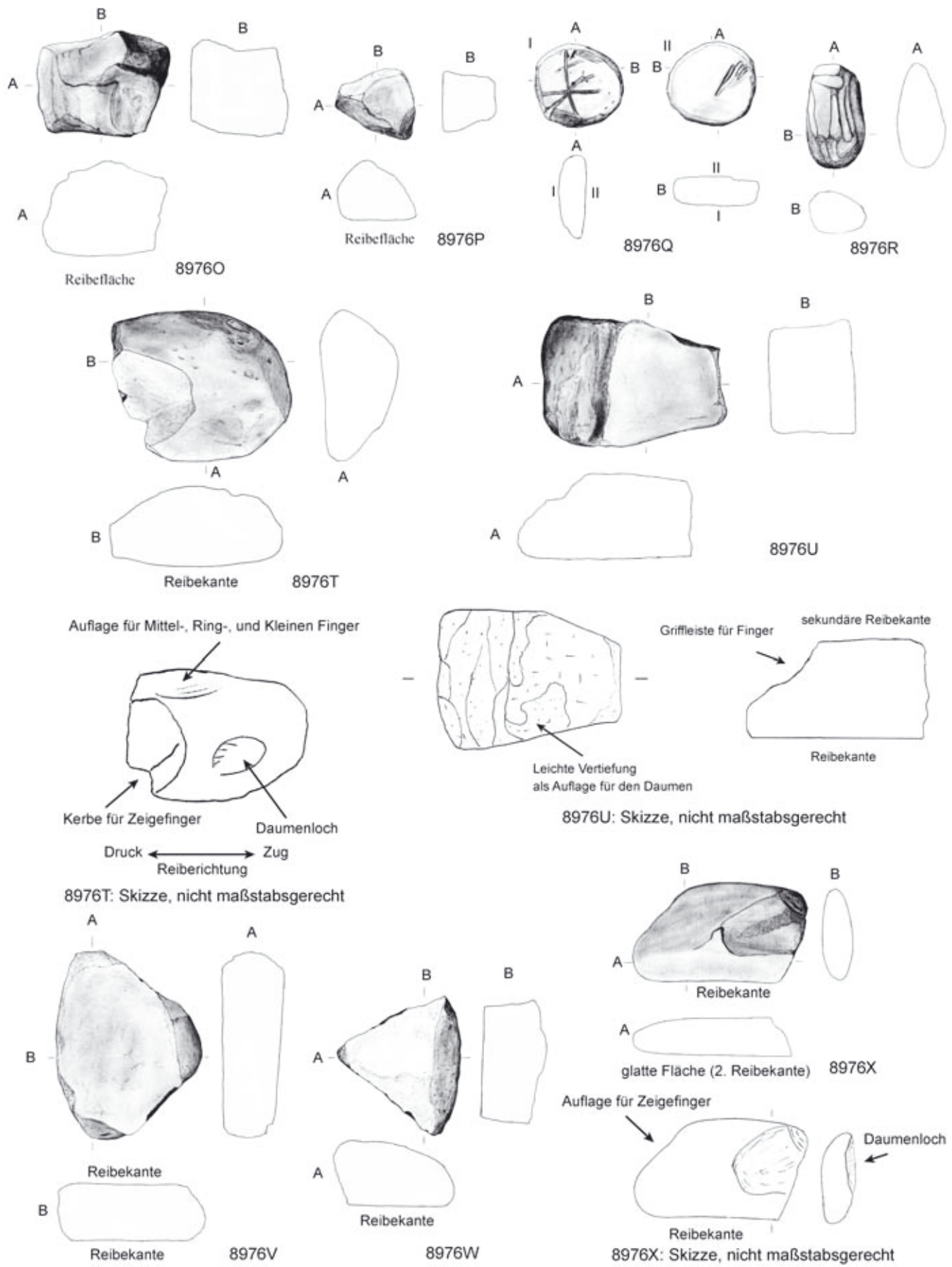

Abb. T164 Reib-, Schleif-, Polier-, Wetz- und Klopffsteine, Hammer

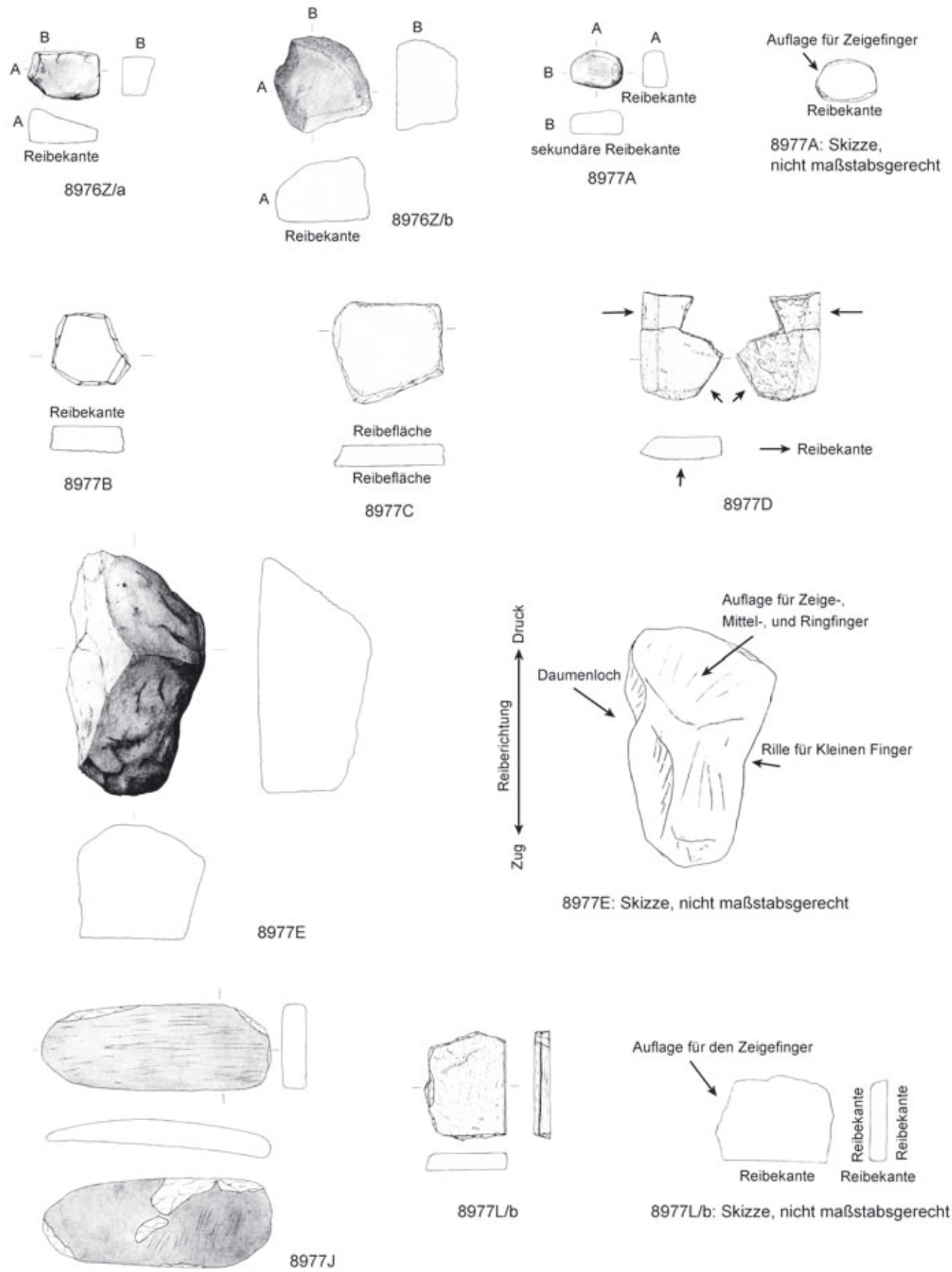

8949A

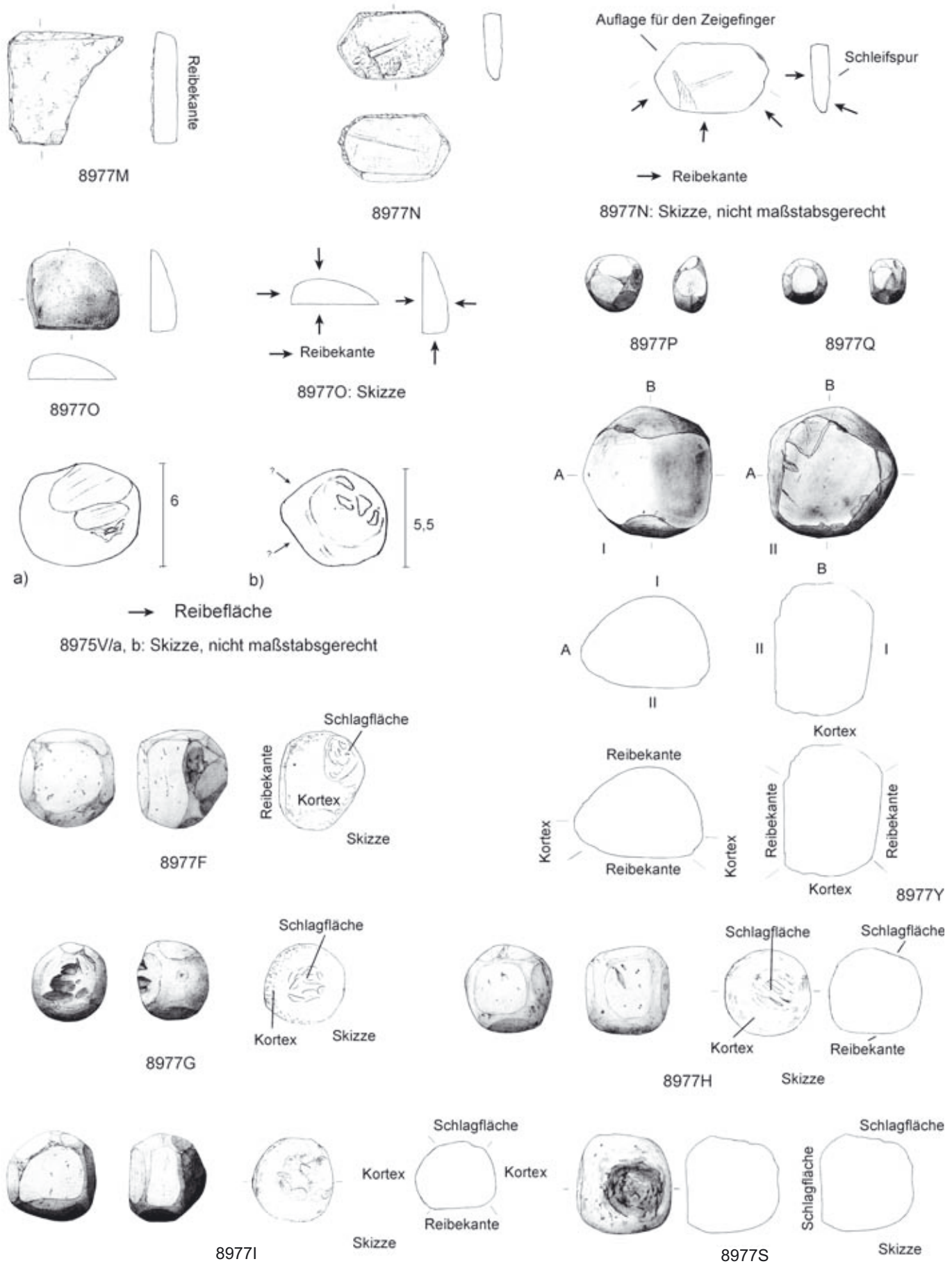
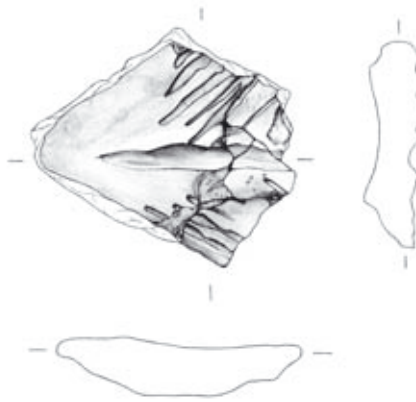
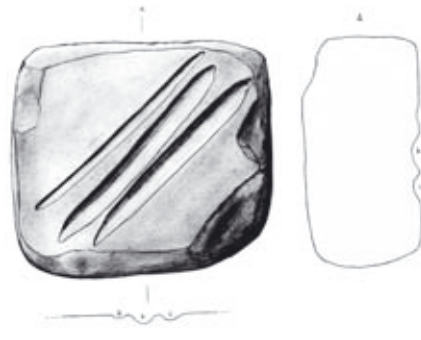

8975W



8976F/g: Skizze, nicht maßstabsgerecht

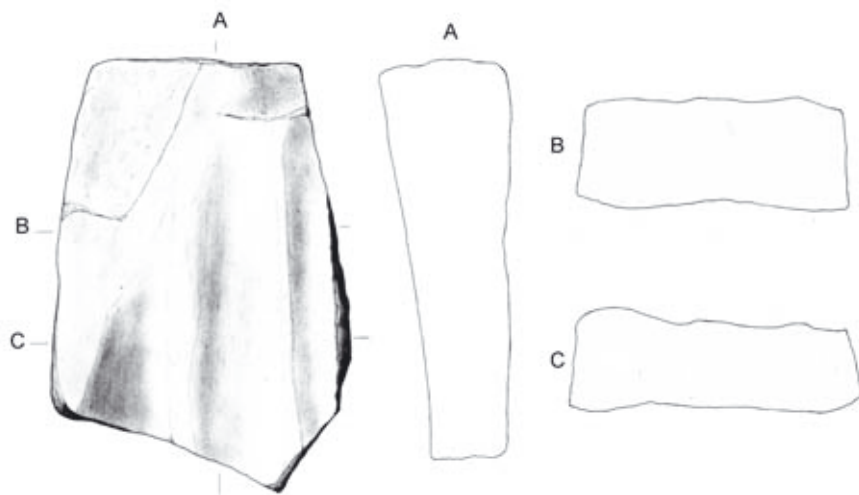

8976S



8977K



8977L/a



8977T

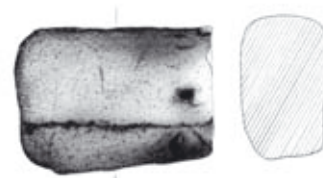

exL254

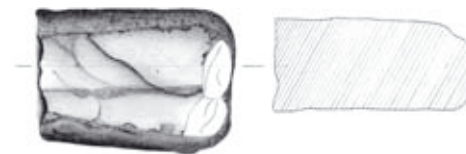

8975P

Abb. T165 Reib-, Schleif-, Polier-, Wetz- und Klopffsteine, Hammer



Abb. T166 Reib-, Schleif-, Polier- Wetz- und Klopffsteine, Hammer: photographische Dokumentation



Abb. T167 Reib-, Schleif-, Polier- Wetz- und Klopffsteine, Hammer: photographische Dokumentation





Abb. T168 Reib-, Schleif-, Polier- Wetz- und Klopffsteine, Hammer: photographische Dokumentation

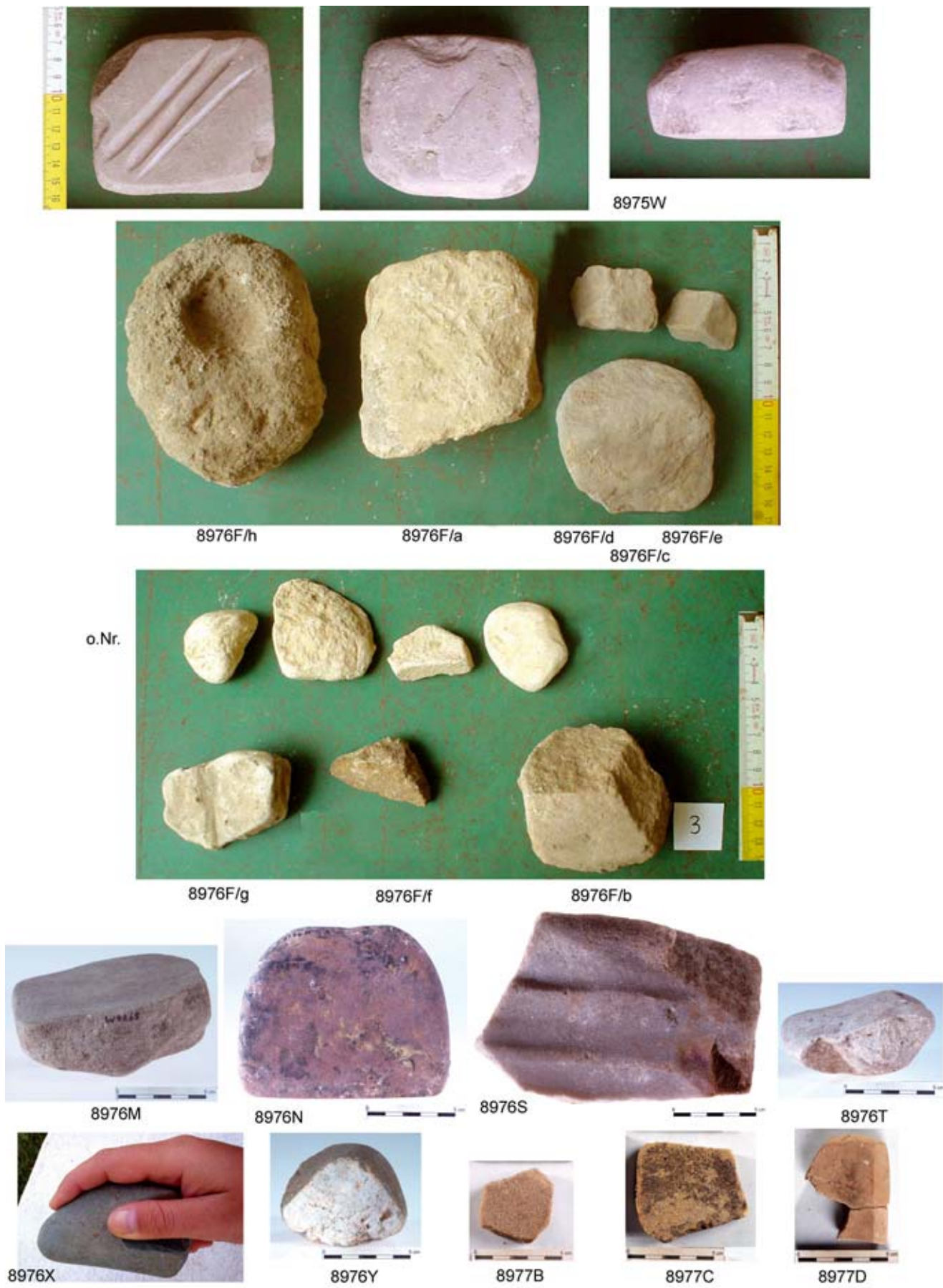
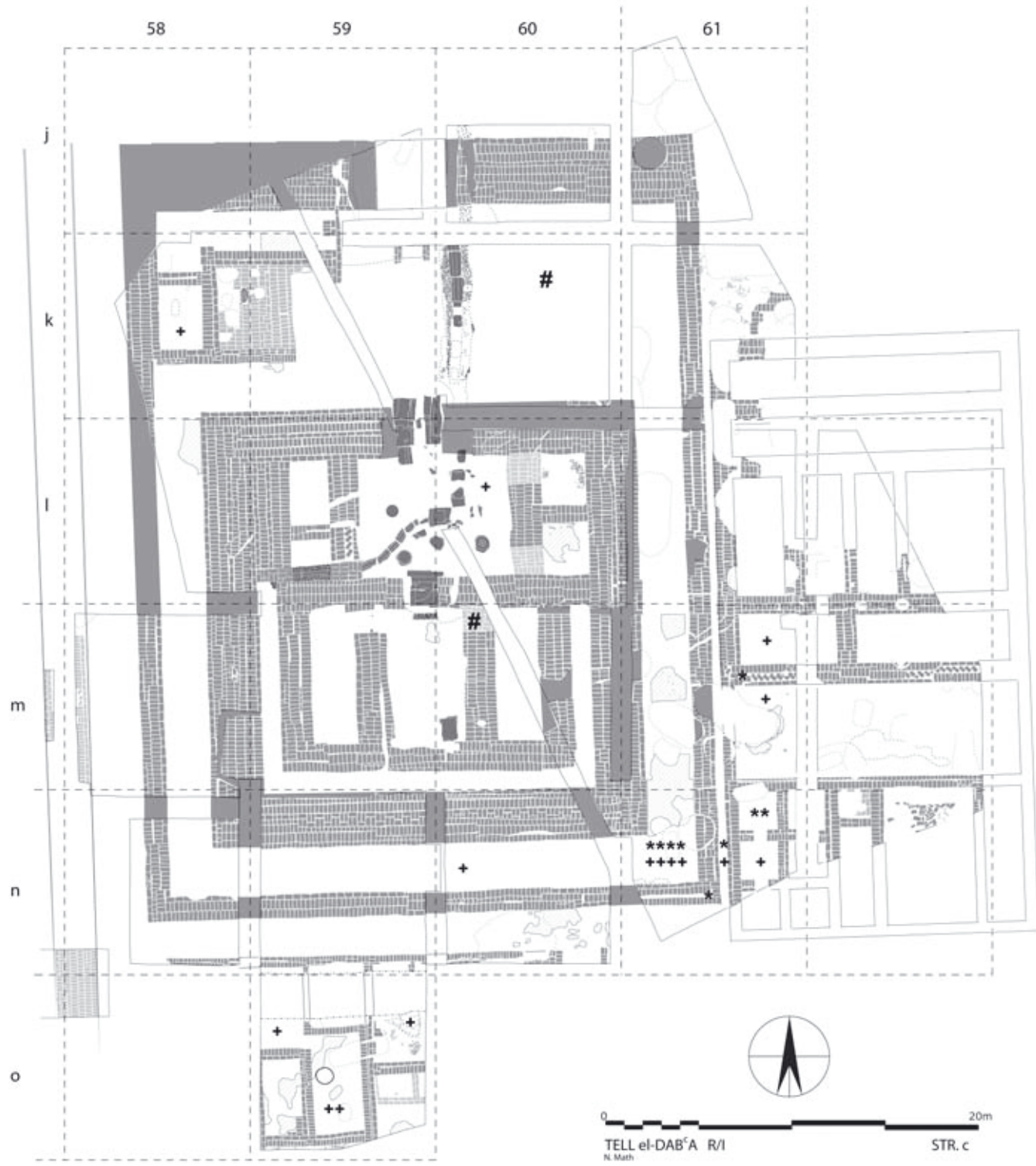

- + : Sicheleinsätze
- \* : Bohrer
- # : Schlachtmesser

Abb. S1 Silices: Fundsituation str.c



- + : Sicheleinsätze
  - \* : Bohrer
  - # : Schlachtmesser
- R/1 str. e/1, Rekonstruktion

Abb. S2 Silices: Fundsituation str. e/1

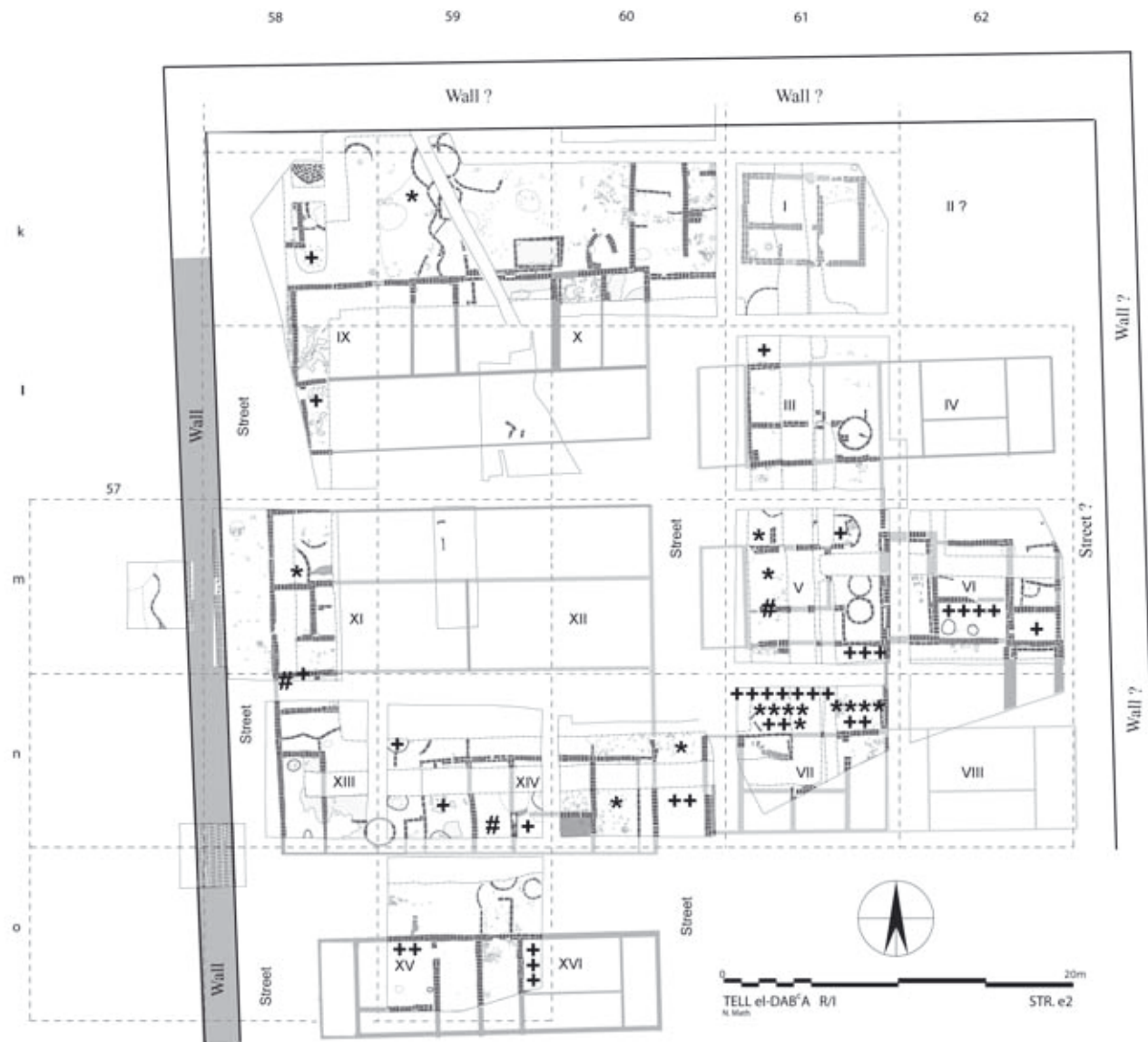

- + : Sicheleinsätze
  - \* : Bohrer
  - # : Schlachtmesser
- R/1 str. e/2, Rekonstruktion

Abb. S3 Silices: Fundsituation str. e/2



R/1 str. e/3, Rekonstruktion

- + : Sicheleinsätze
- \* : Bohrer
- # : Schlachtmesser

Abb. S4 Silices: Fundsituation str. e/3



+ : Sicheleinsätze R/I, str. e/4  
 \* : Bohrer

Abb. S5 Silices: Fundsituation str. e/4

Altstücke

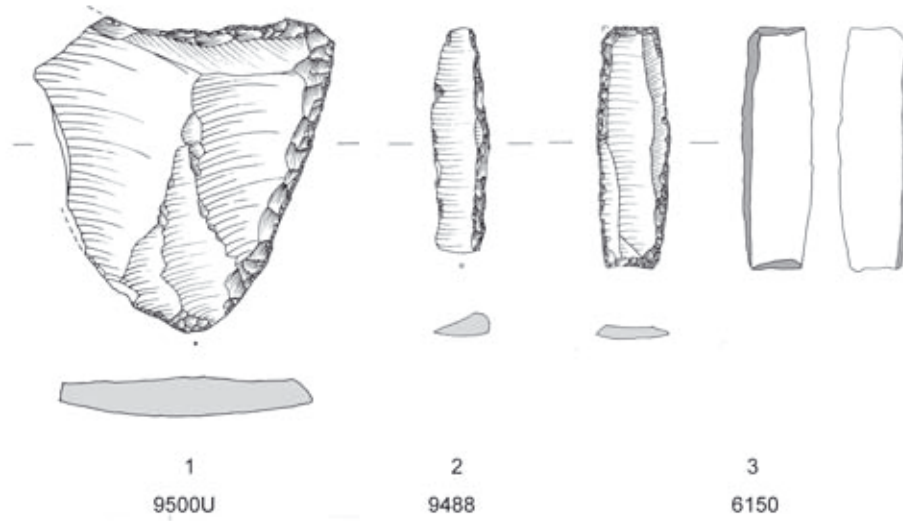

Bohrer

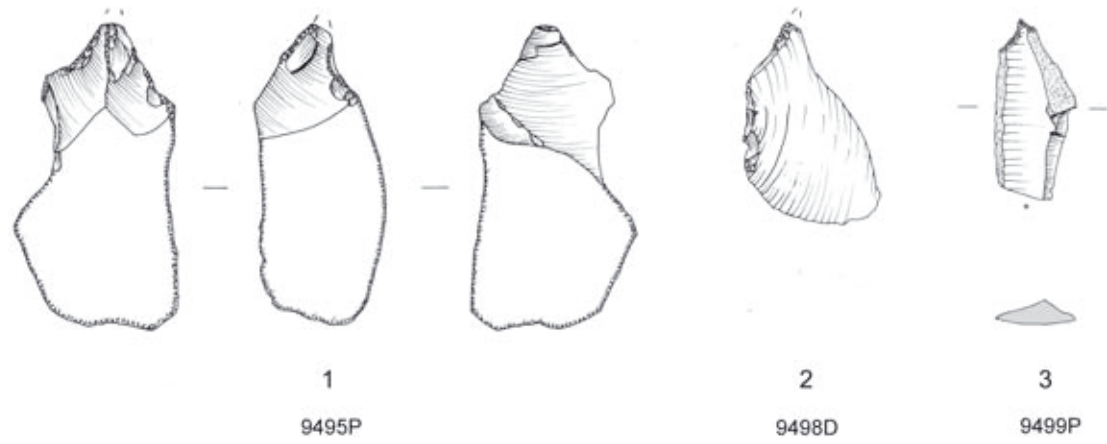

Endretuschierte Stücke



Abb. S6 Silices: Typologie und Zeichnungen nach A. Tillmann

Flächenretuschierte Messer



Abb. S7 Silices: Typologie und Zeichnungen nach A. Tillmann

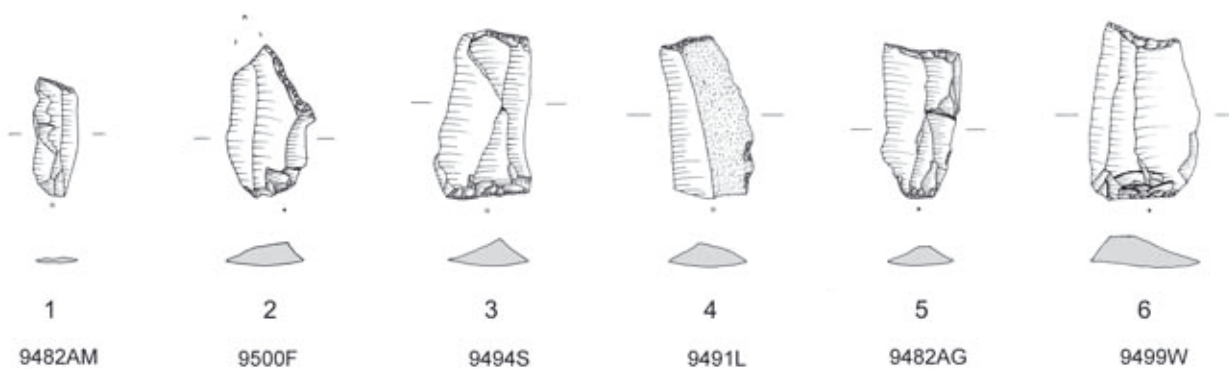

Flächenretuschierte Messer 2

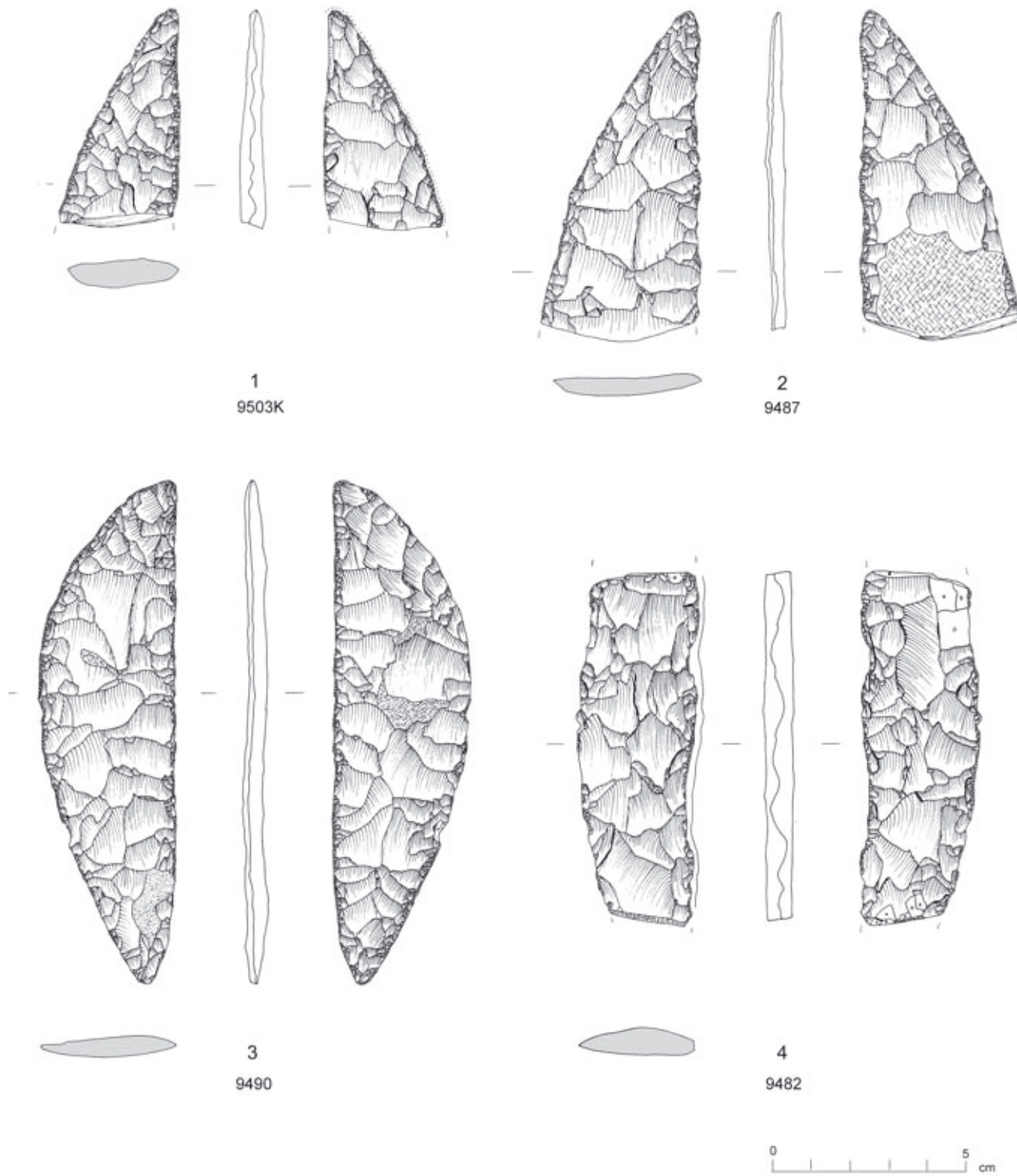

Abb. S8 Silices: Typologie und Zeichnungen nach A. Tillmann

Geröllbohrer

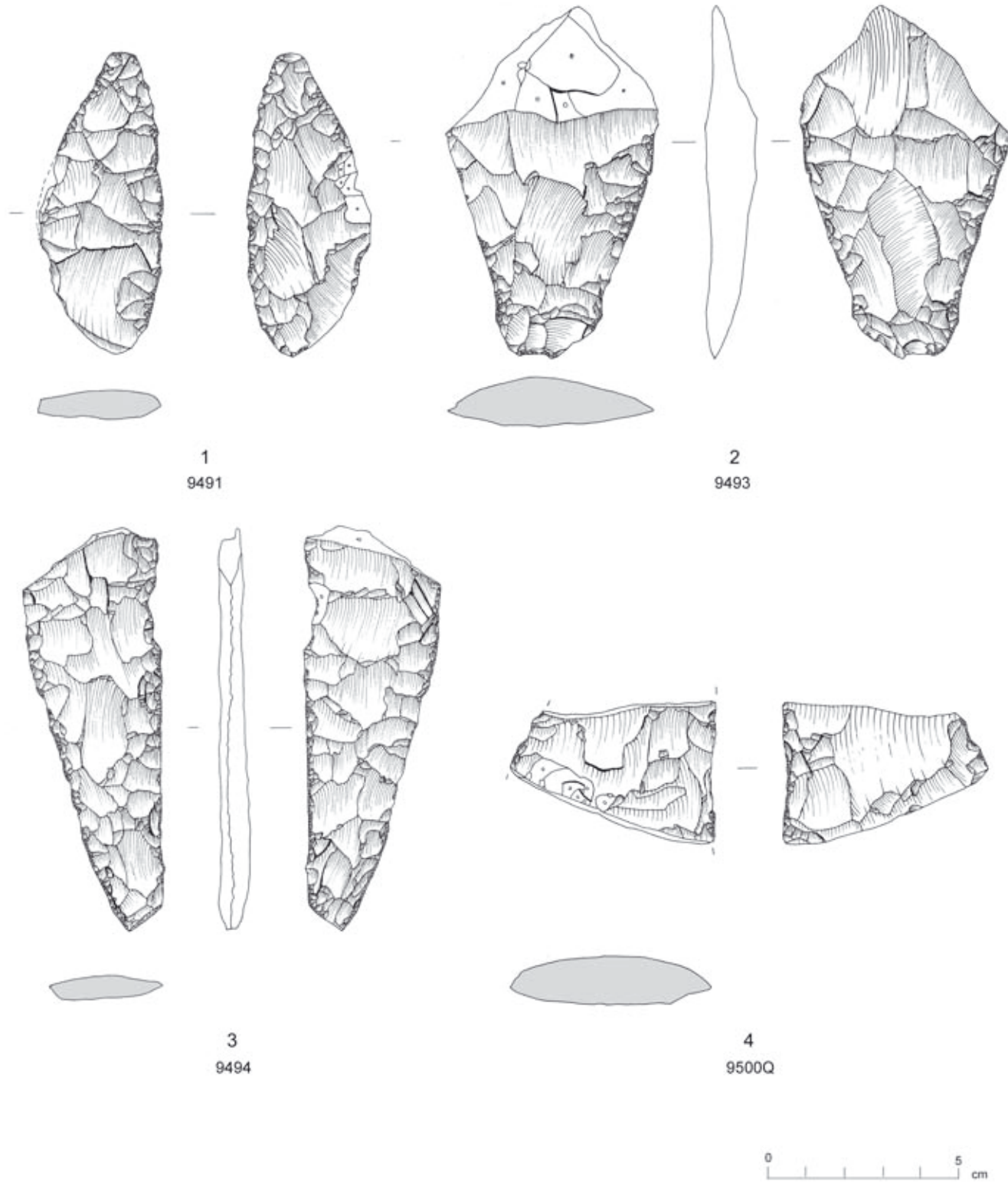

Abb. S9 Silices: Typologie und Zeichnungen nach A. Tillmann

Kernkantenklingen



Kernsteine

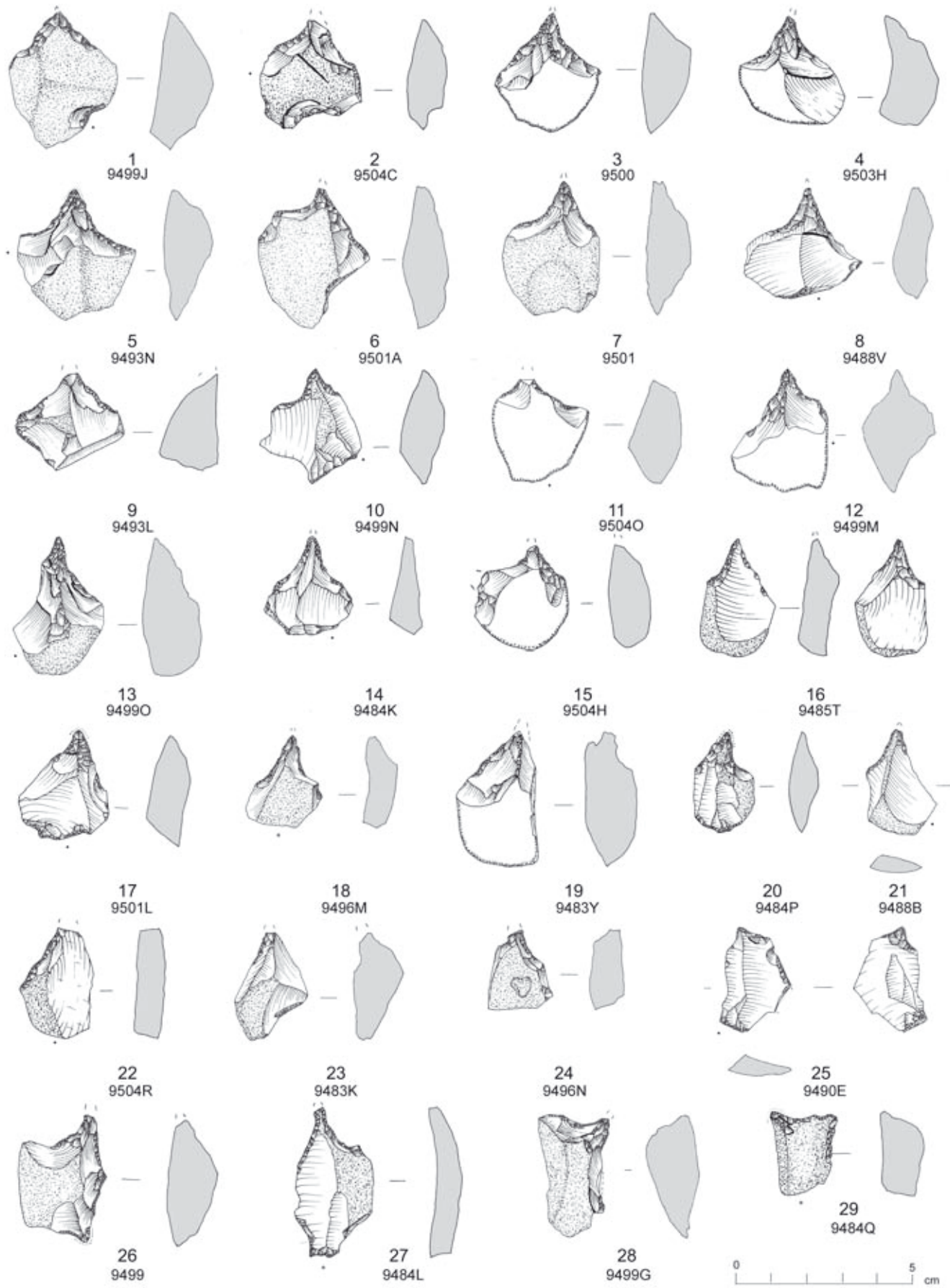
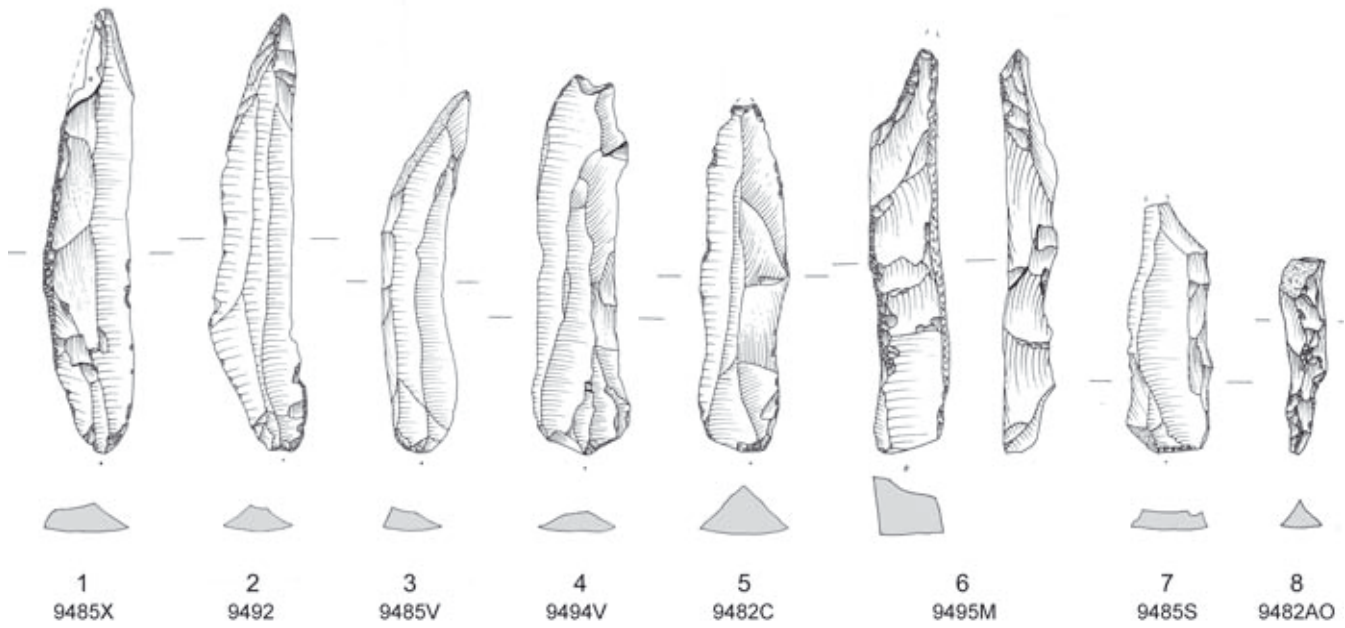
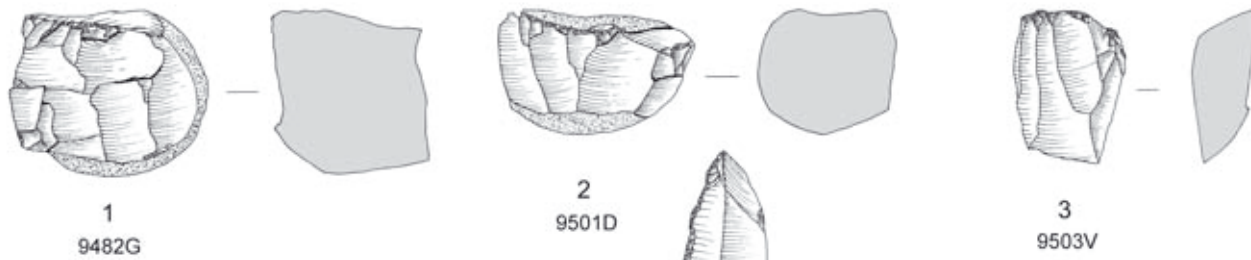

Schaber, Kratzer



Abb. S10 Silices: Typologie und Zeichnungen nach A. Tillmann

Klingen

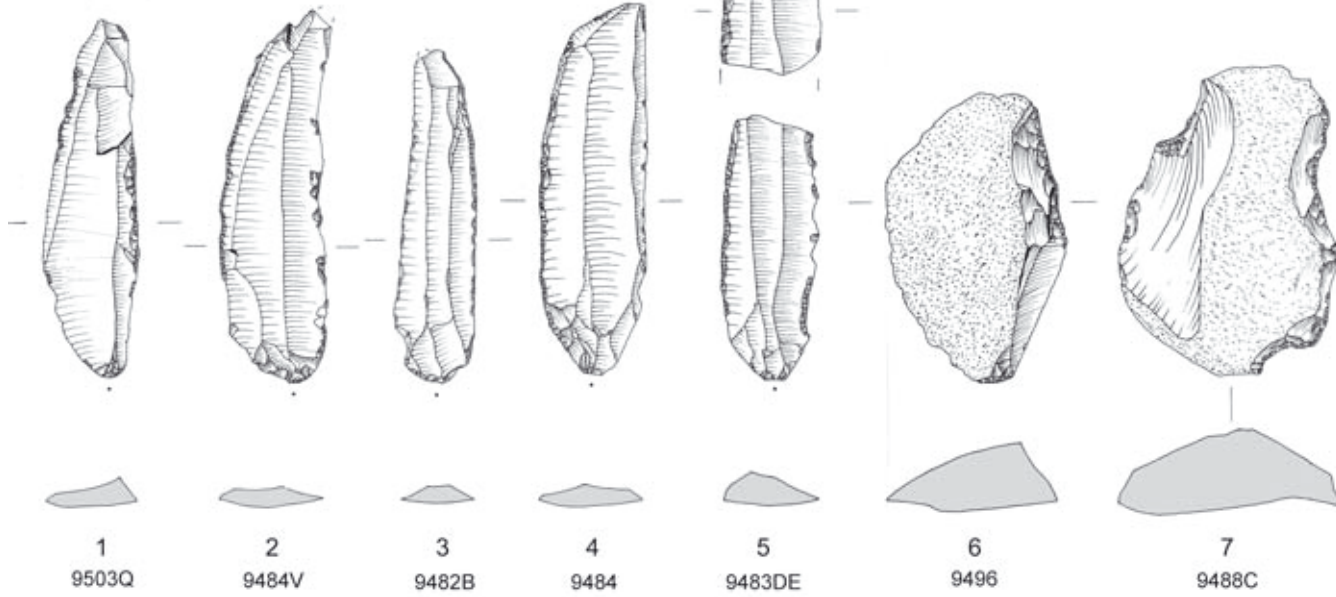

Abb. S11 Silices: Typologie und Zeichnungen nach A. Tillmann

Sichelsteine Typ C

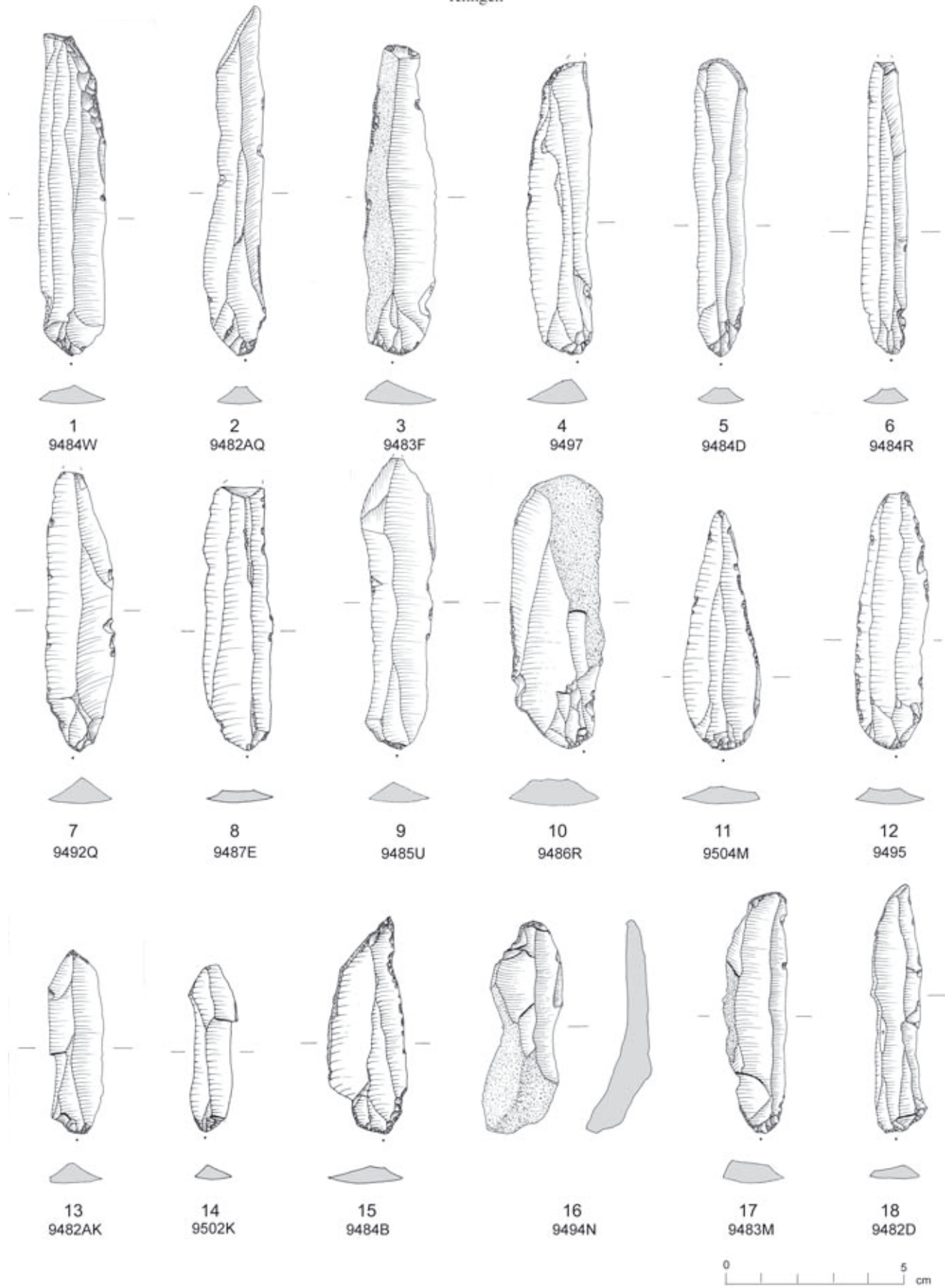

Abb. S12 Silices: Typologie und Zeichnungen nach A. Tillmann

Sichelsteine Typ D

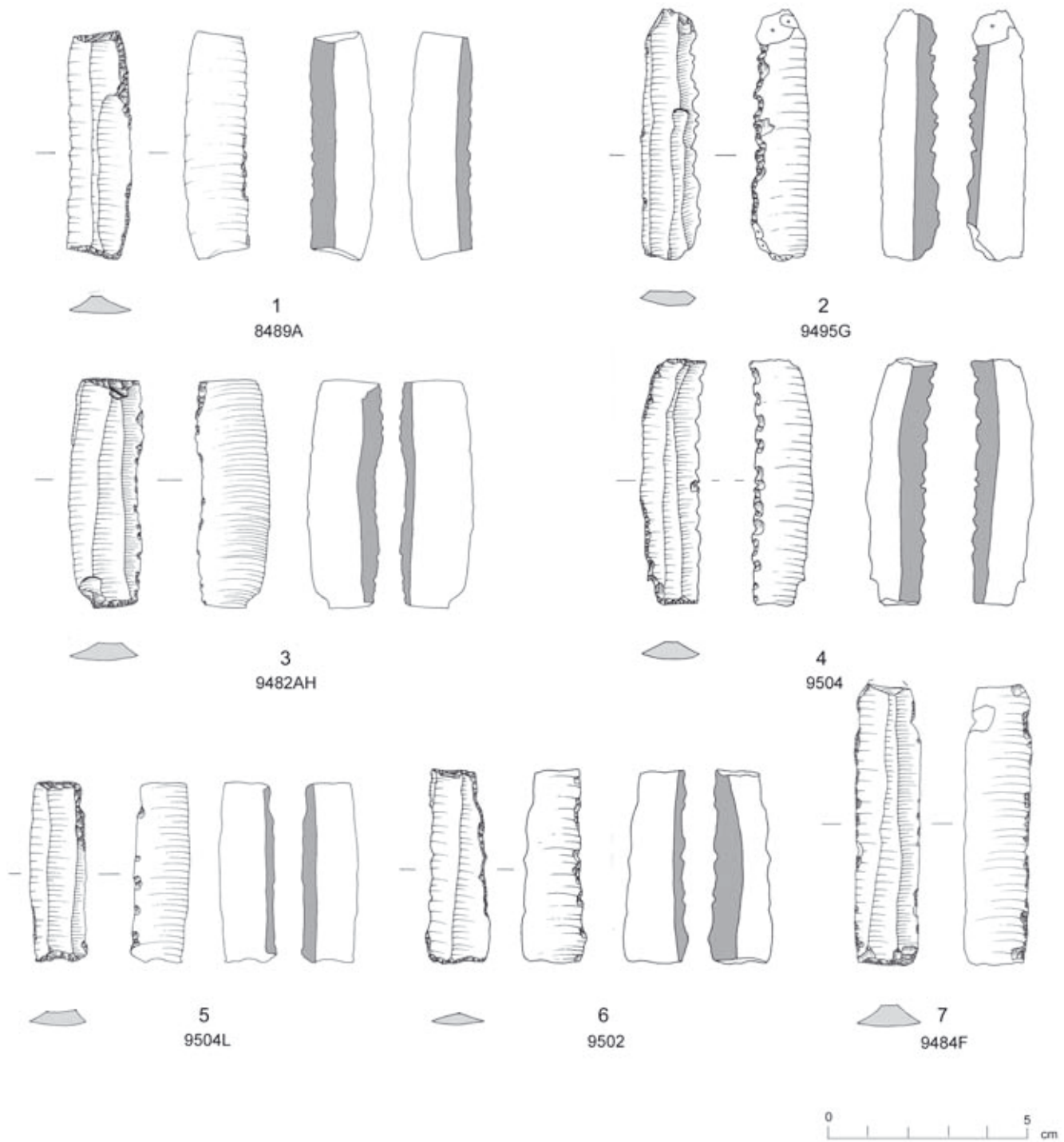

Abb. S13 Silices: Typologie und Zeichnungen nach A. Tillmann

Sichelsteine Typ D (2)



Abb. S14 Silices: Typologie und Zeichnungen nach A. Tillmann

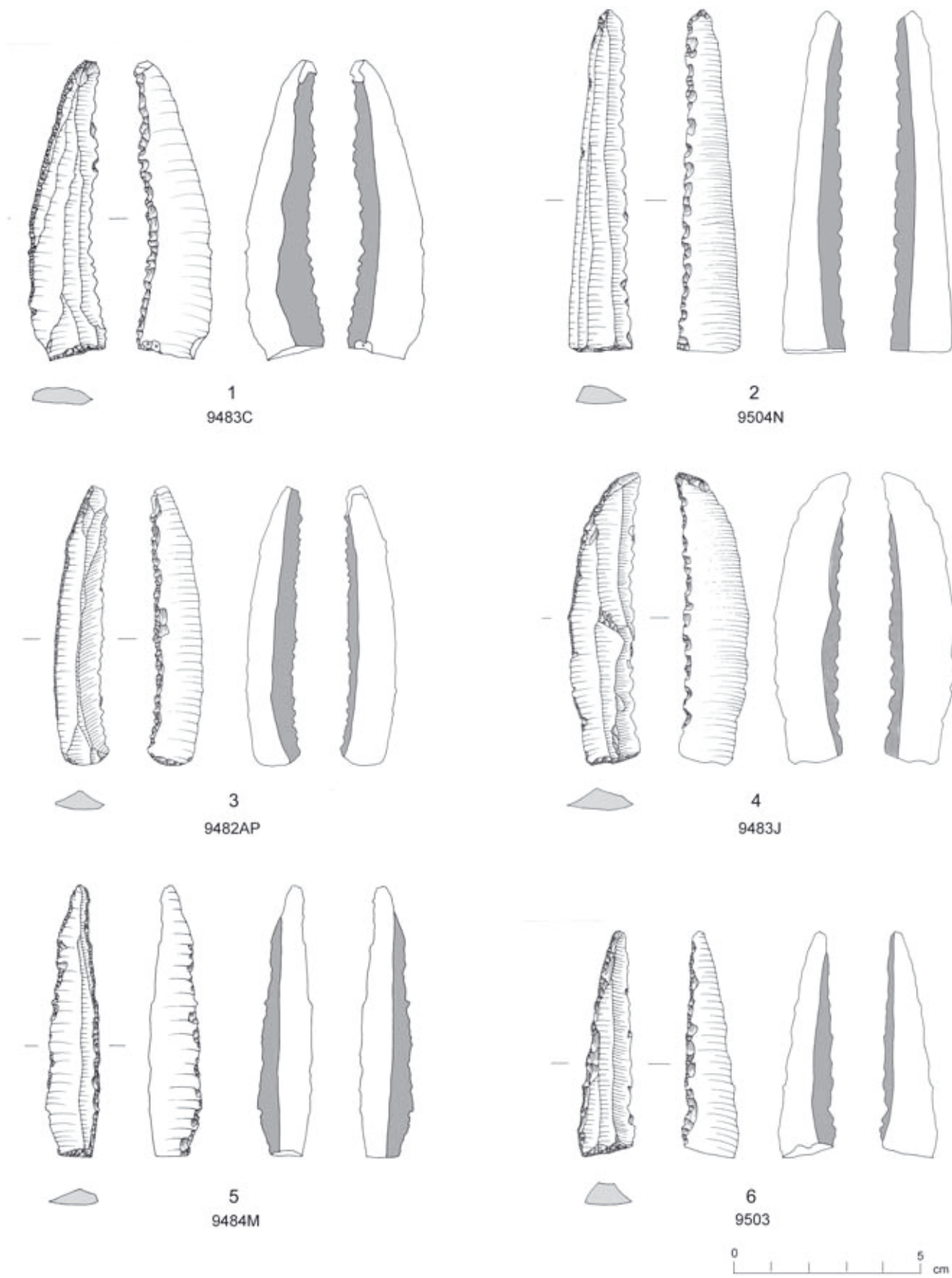

Abb. S15 Silices: Typologie und Zeichnungen nach A. Tillmann



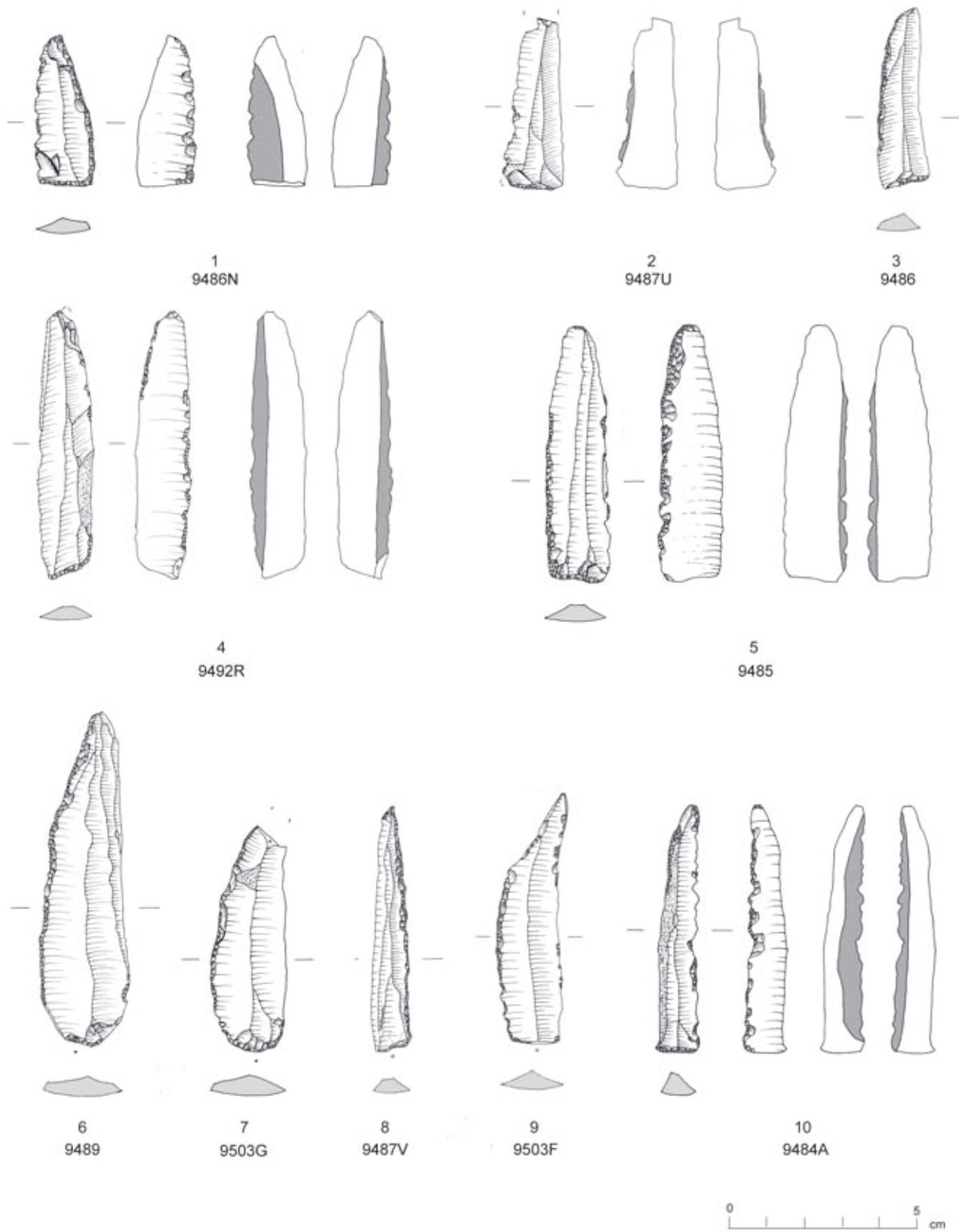

9481

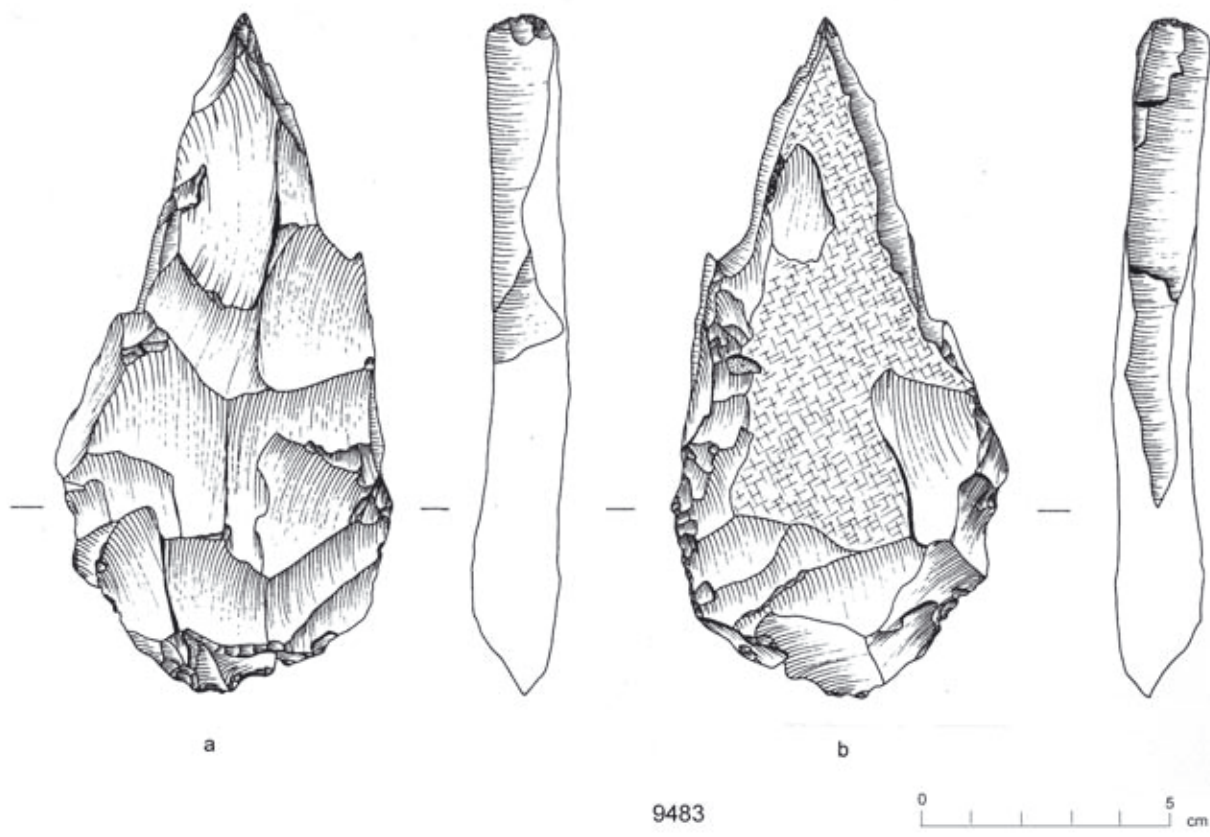
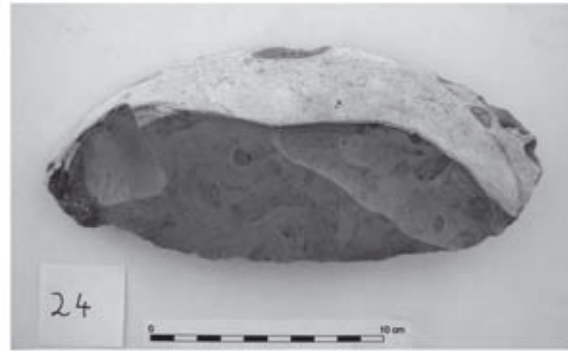

9482 9482B 9482C 9482A 9482D 9482E

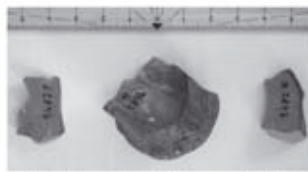
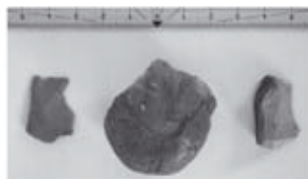

9482F 9482G 9482H

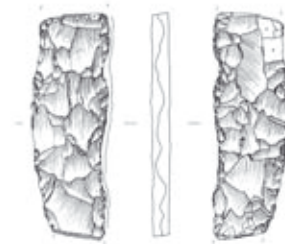

9482

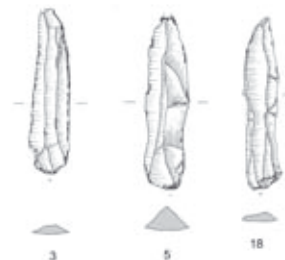

9482B 9482C 9482D



9482G

Abb. S16 Silices: nach Inv. Nr. geordnet

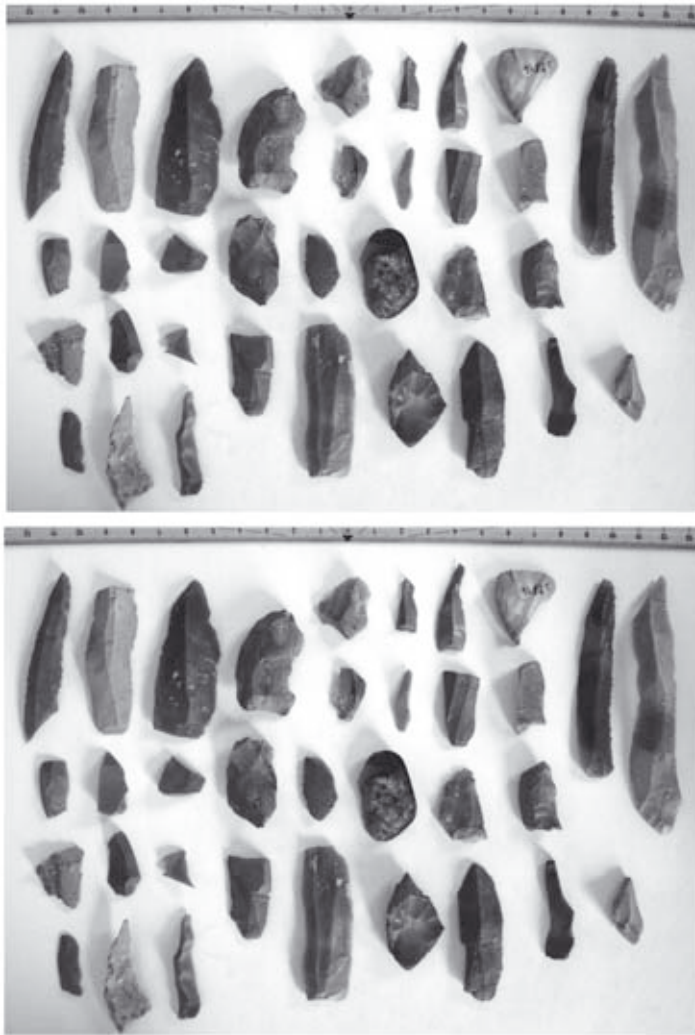

9482J-9482Z; 9482AA-9482AR

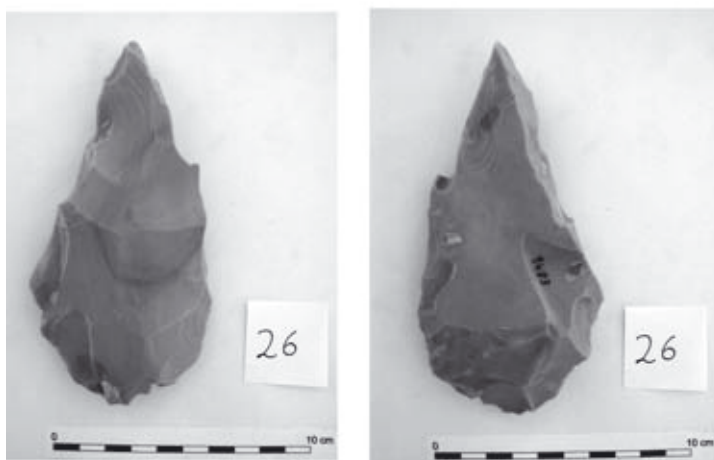

9483

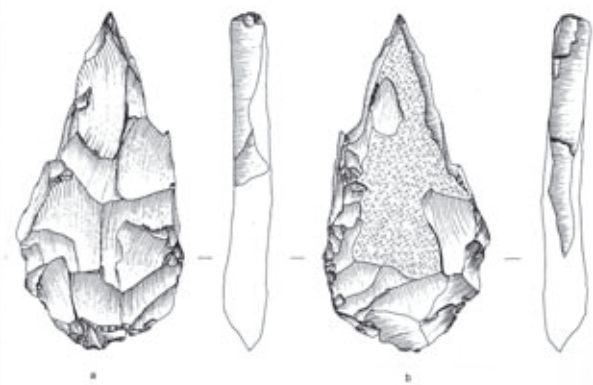

9483

Abb. S17 Silices: nach Inv. Nr. geordnet



Abb. S18 Silices: nach Inv. Nr. geordnet



Abb. S19 Silices: nach Inv. Nr. geordnet

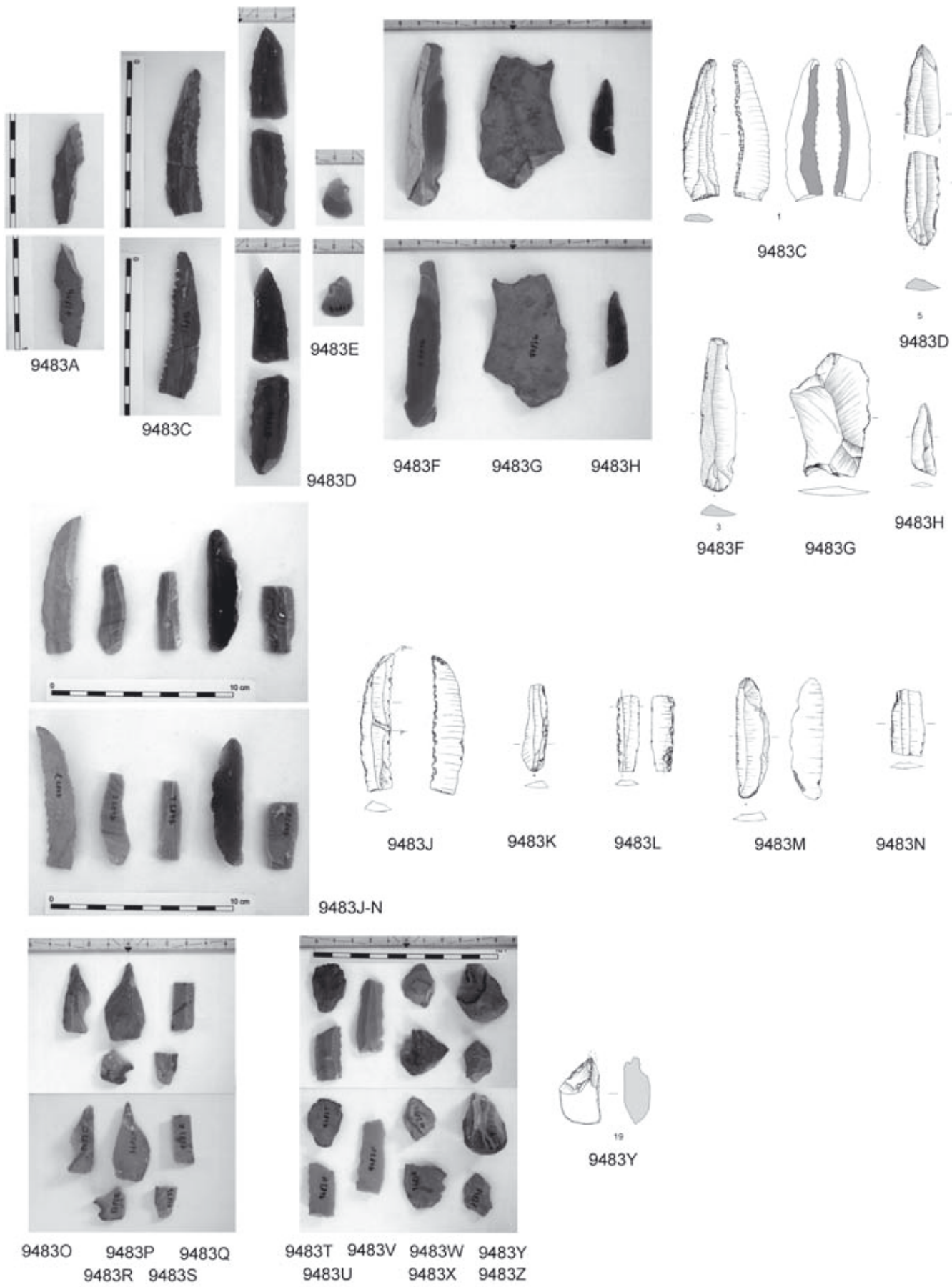

9485W

9485U 9485X

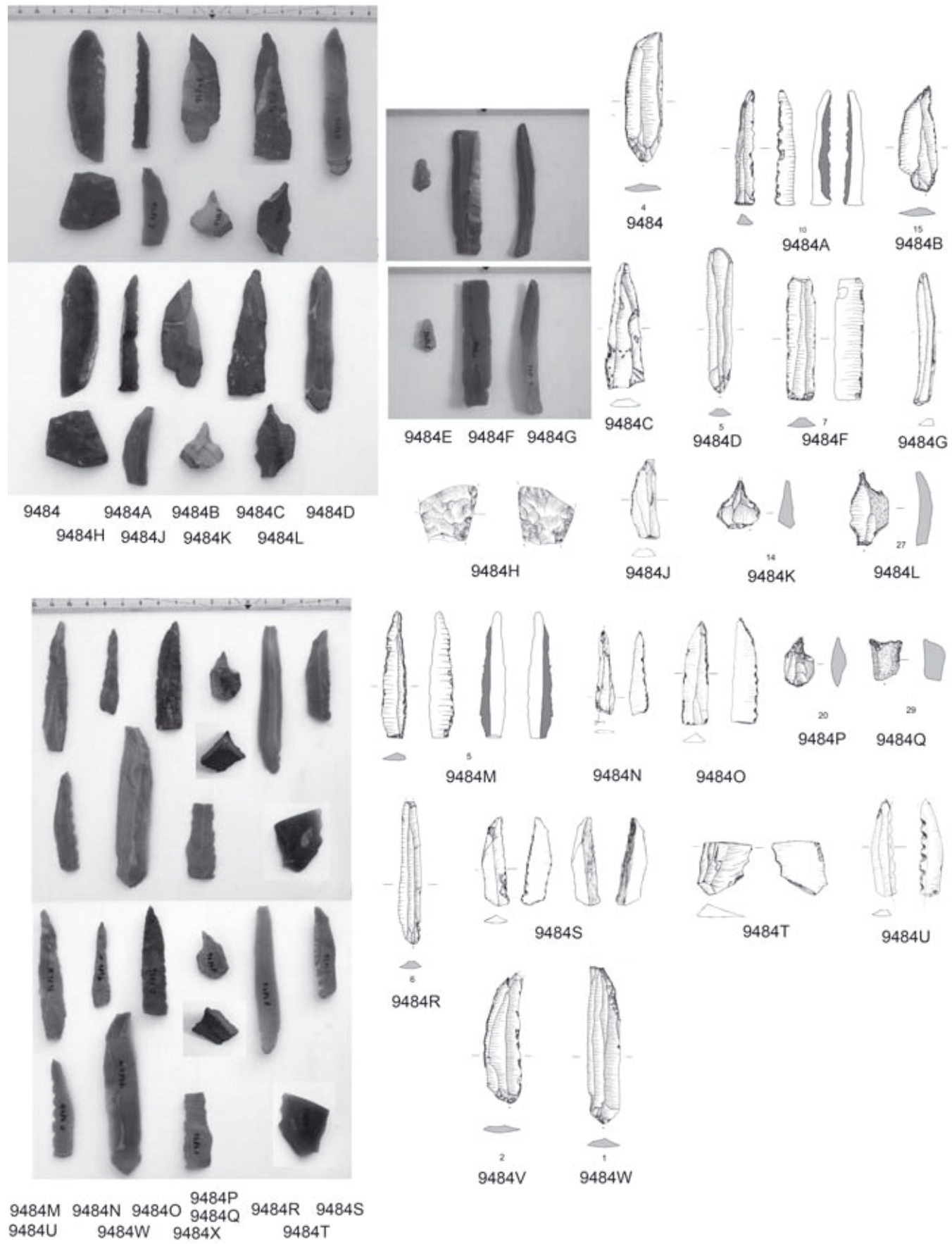
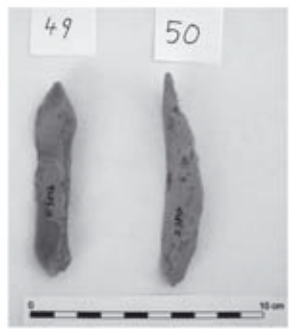
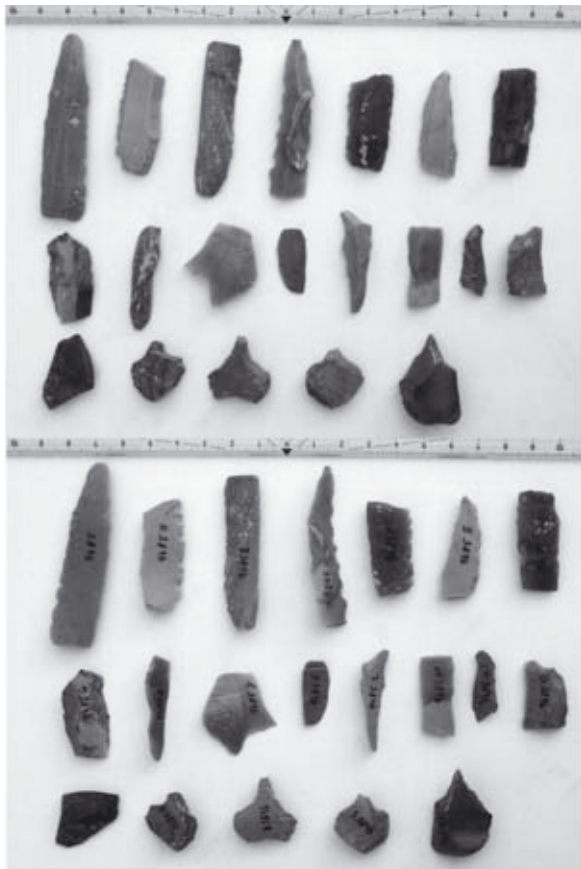
9485 9485A 9485B 9485C 9485D 9485D 9485E 9485F  
 9485G 9485H 9485J 9485K 9485L 9485M 9485N 9485O  
 9485P 9485Q 9485R 9485S 9485T

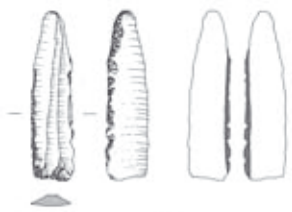

9485



9485S



9485T



9485U



9485V



9485W



9485X



9486 9486A



9486

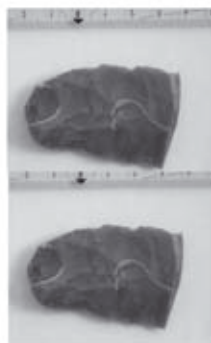

9486B



9486B



9486C 9486D



9486D

Abb. S20 Silices: nach Inv. Nr. geordnet



Abb. S21 Silices: nach Inv. Nr. geordnet



Abb. S22 Silices: nach Inv. Nr. geordnet

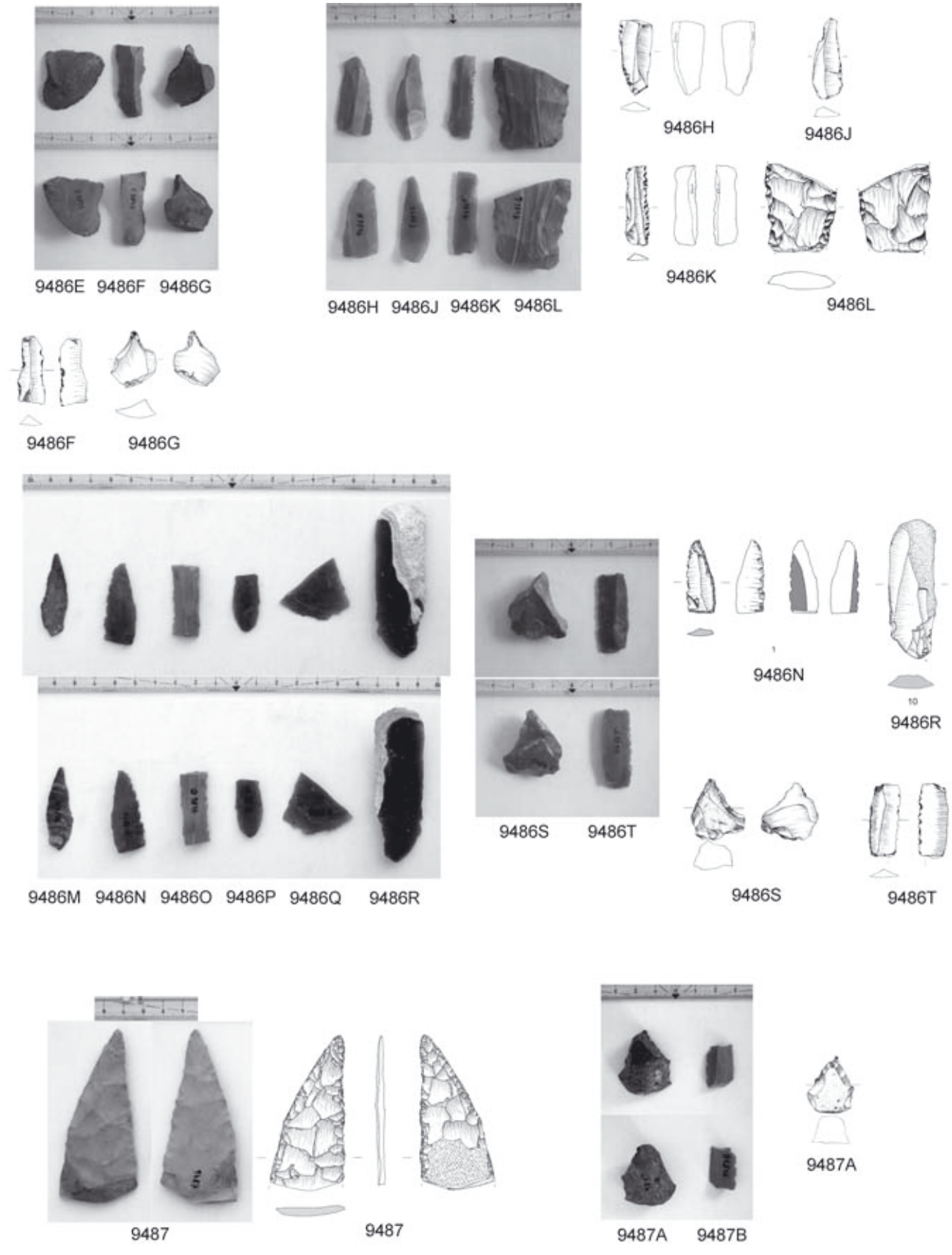

Abb. S23 Silices: nach Inv. Nr. geordnet



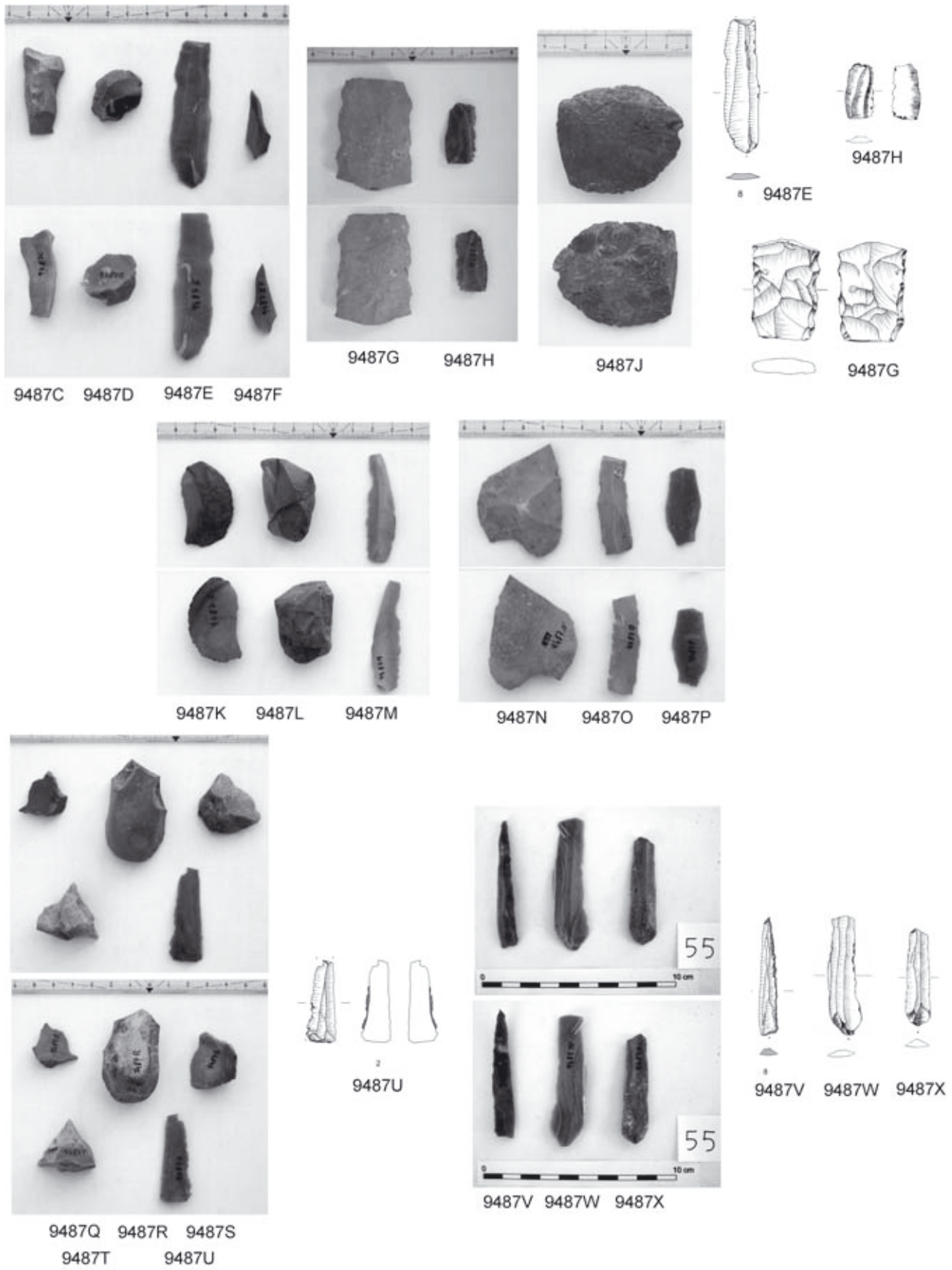

Abb. S24 Silices: nach Inv. Nr. geordnet

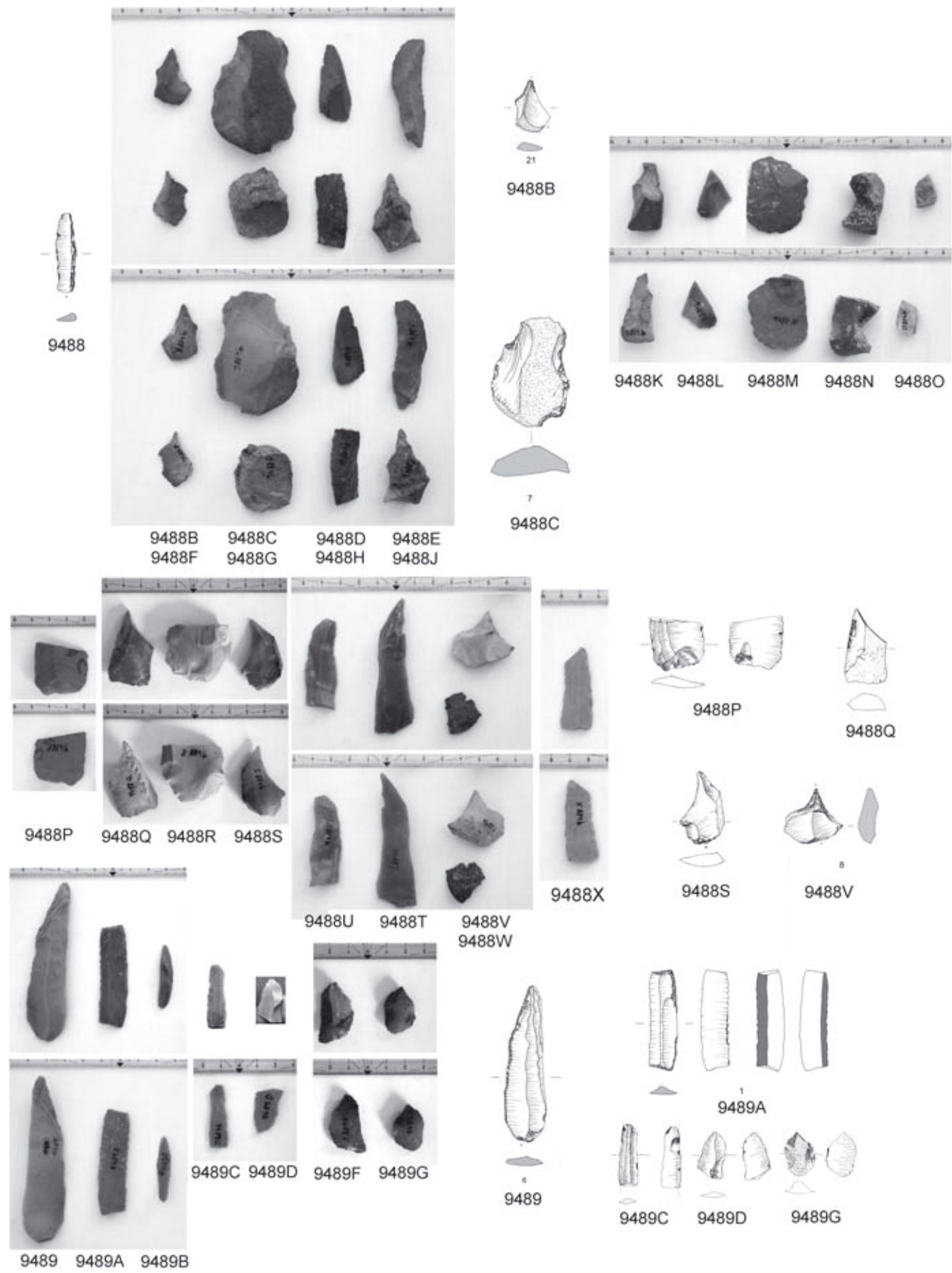

Abb. S25 Silices: nach Inv. Nr. geordnet

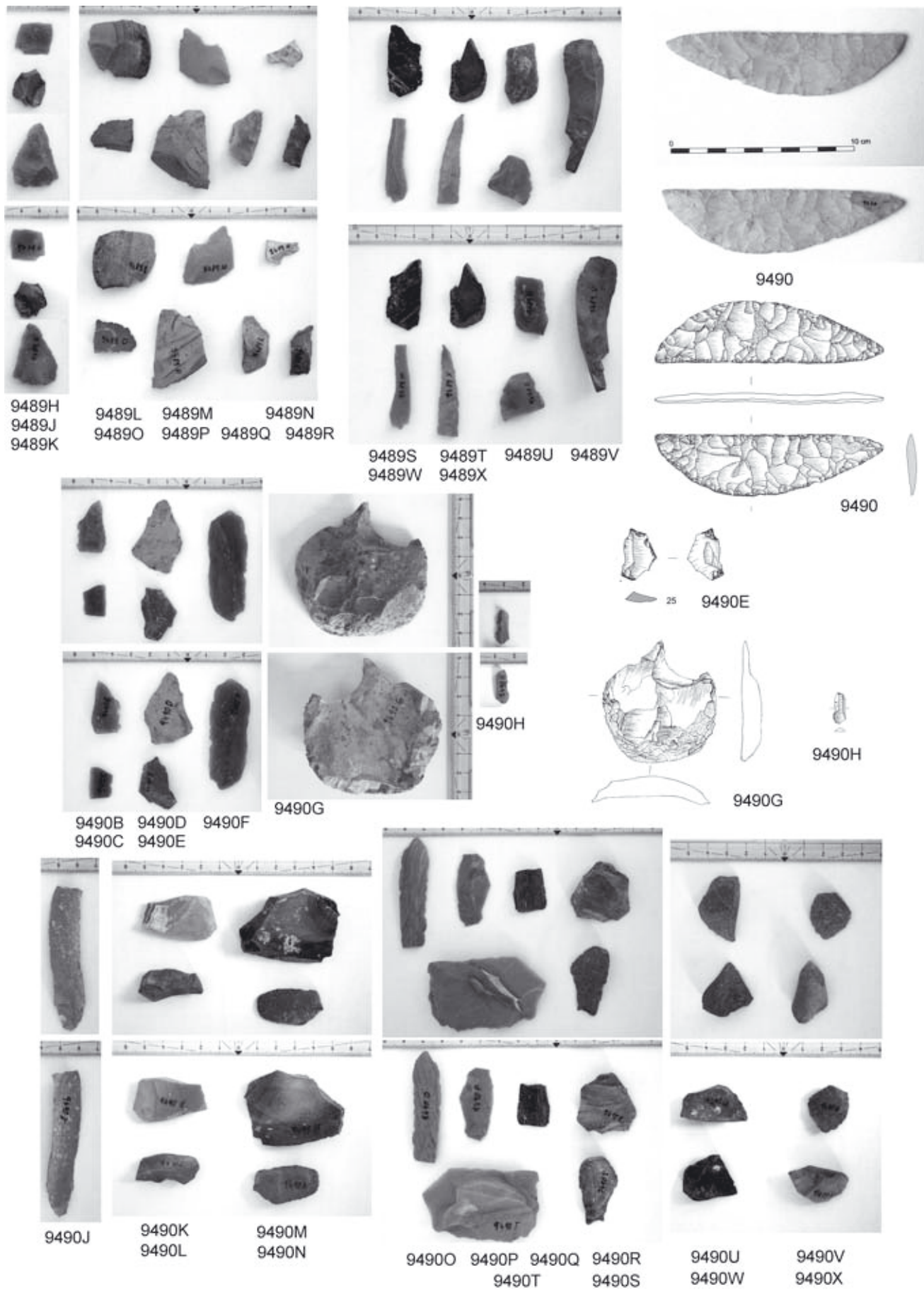

Abb. S26 Silices: nach Inv. Nr. geordnet

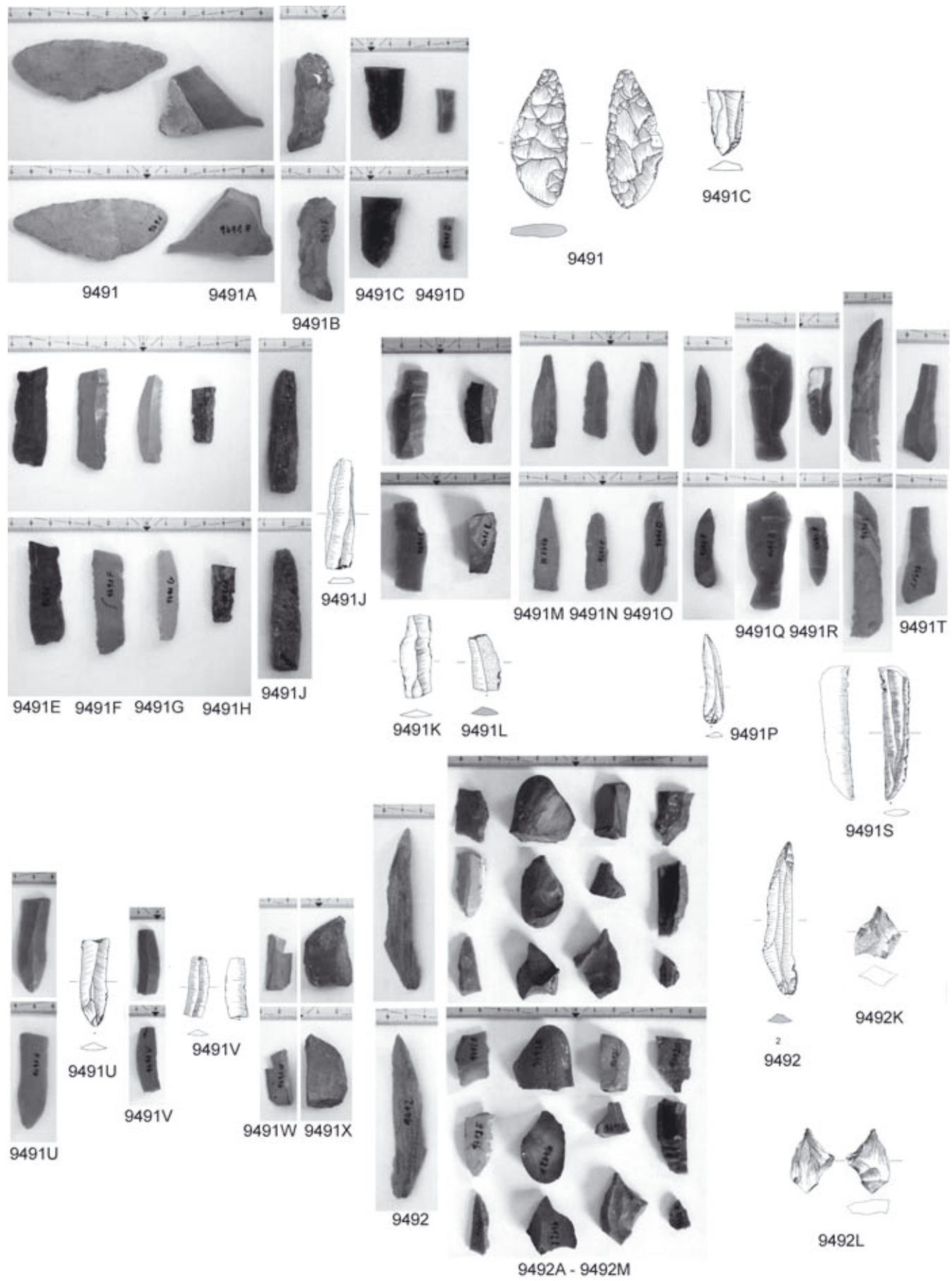

Abb. S27 Silices: nach Inv. Nr. geordnet

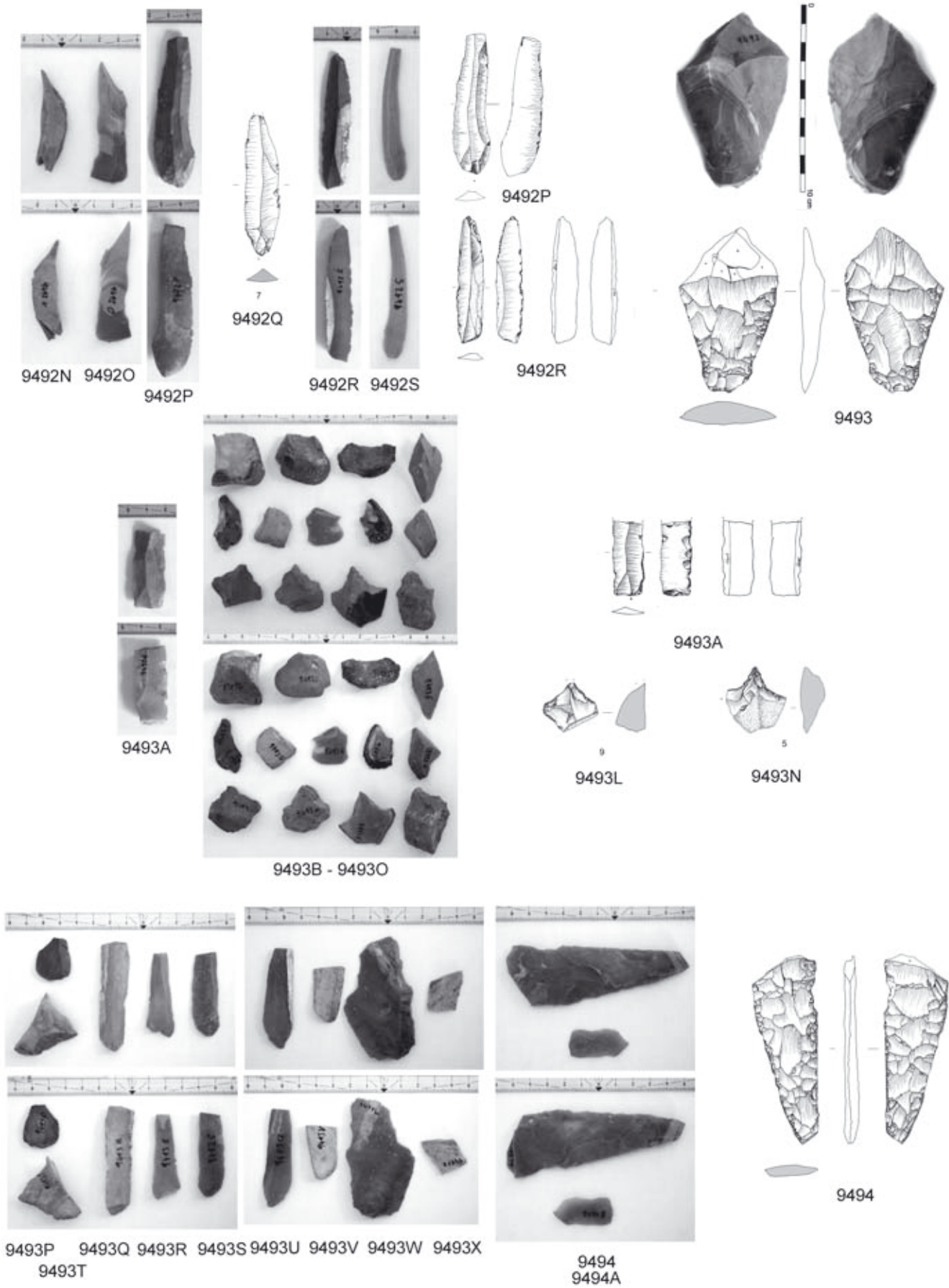

Abb. S28 Silices: nach Inv. Nr. geordnet

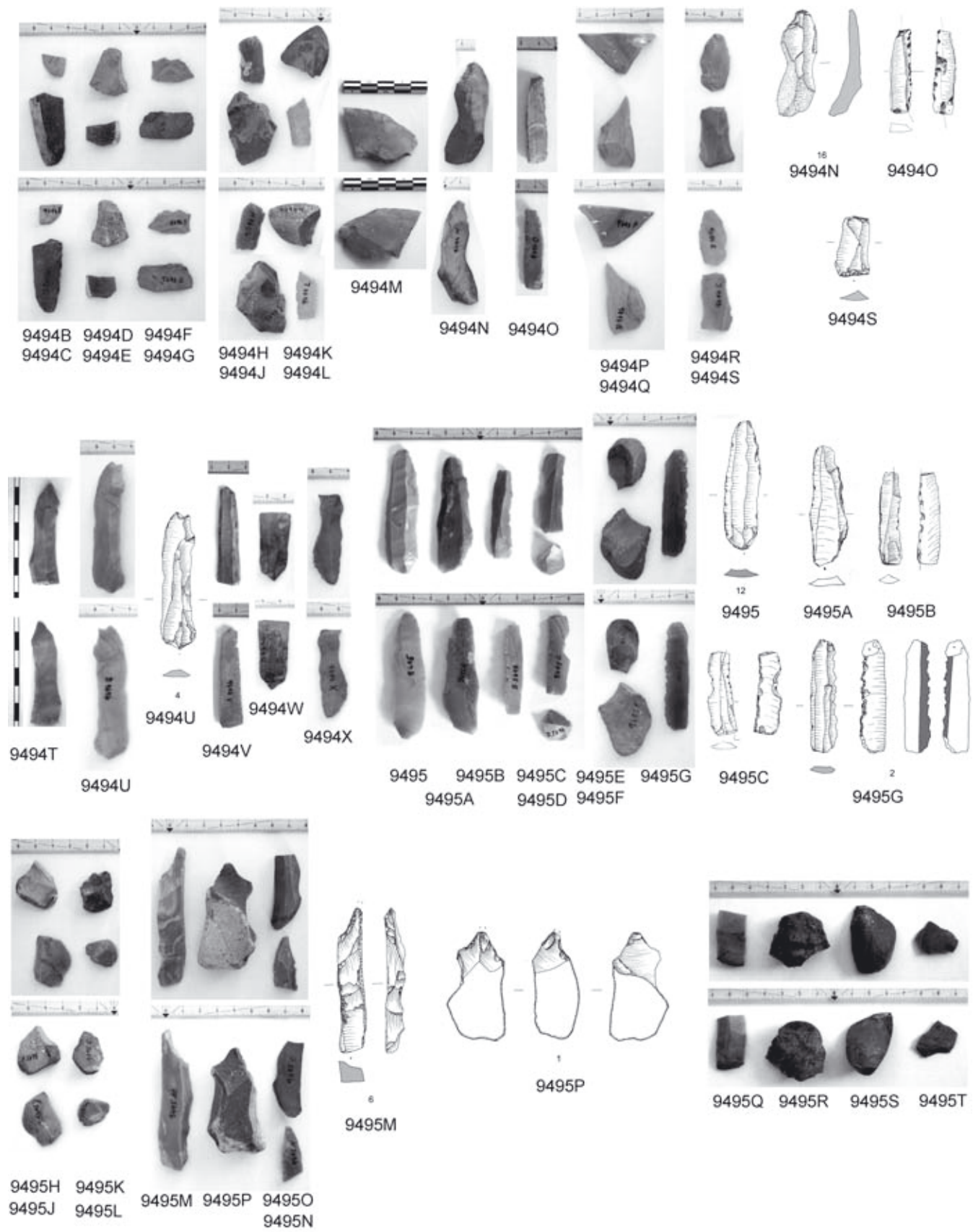

Abb. S29 Silices: nach Inv. Nr. geordnet

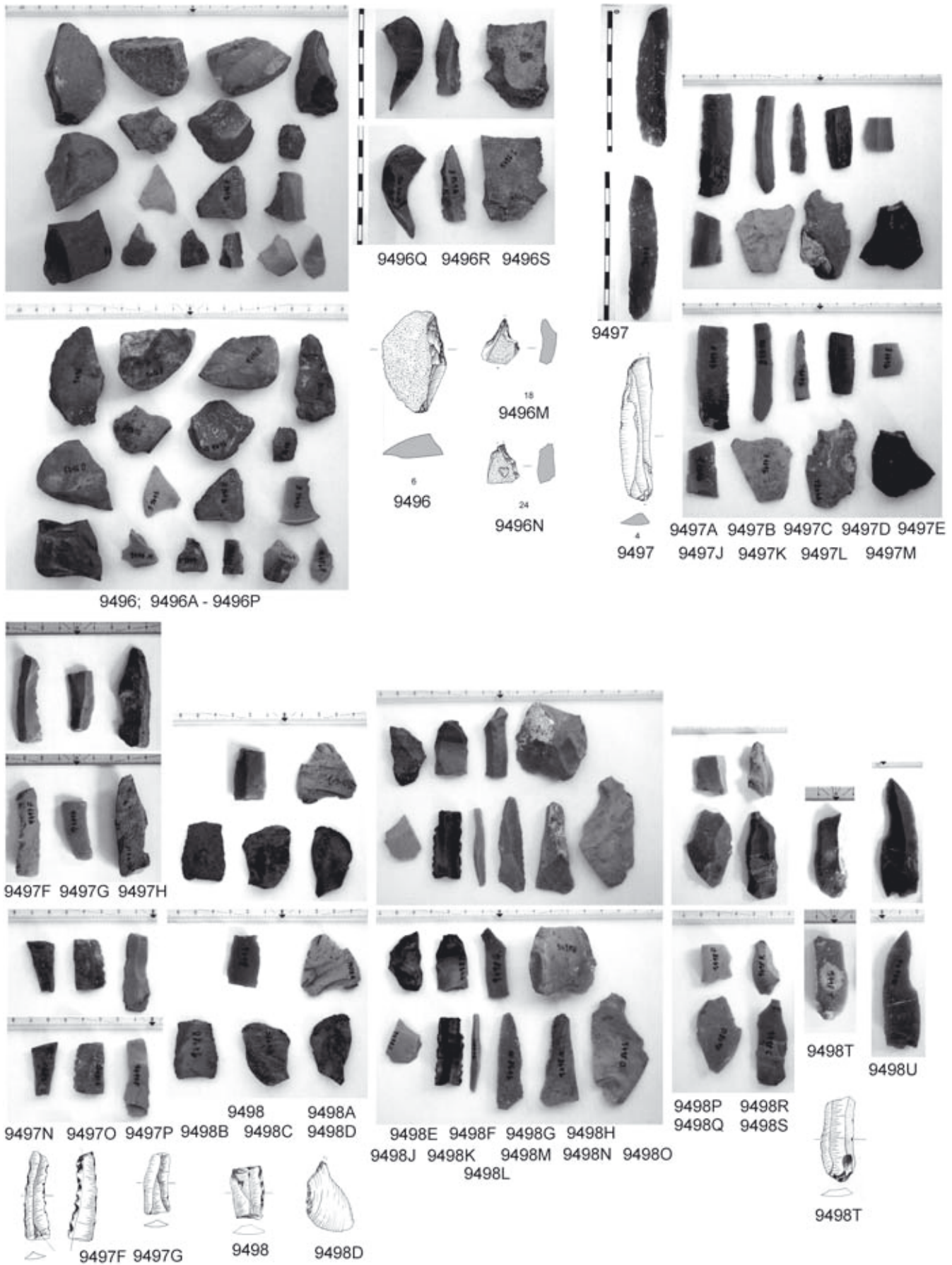

Abb. S30 Silices: nach Inv. Nr. geordnet

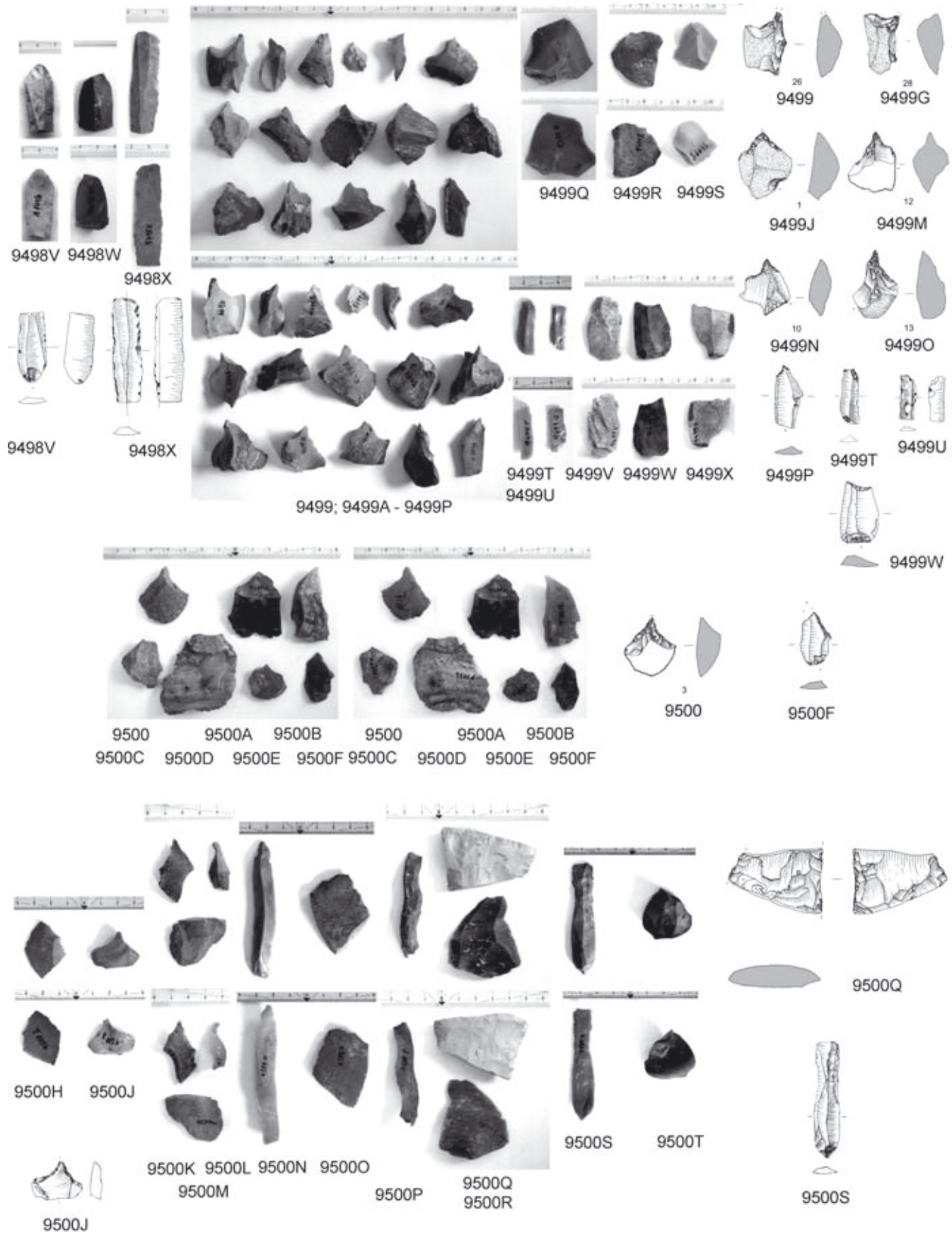

Abb. S31 Silices: nach Inv. Nr. geordnet



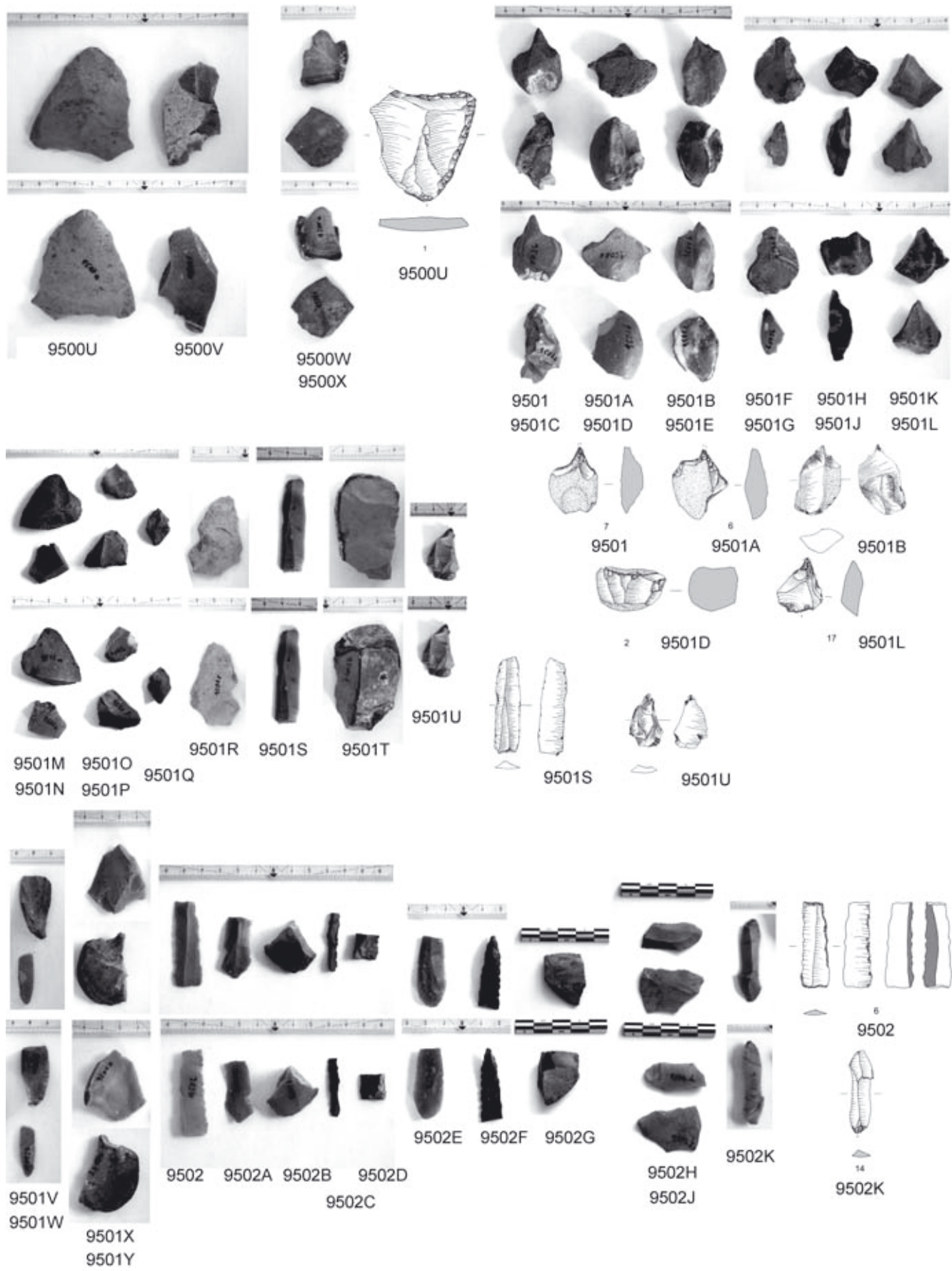

Abb. S32 Silices: nach Inv. Nr. geordnet

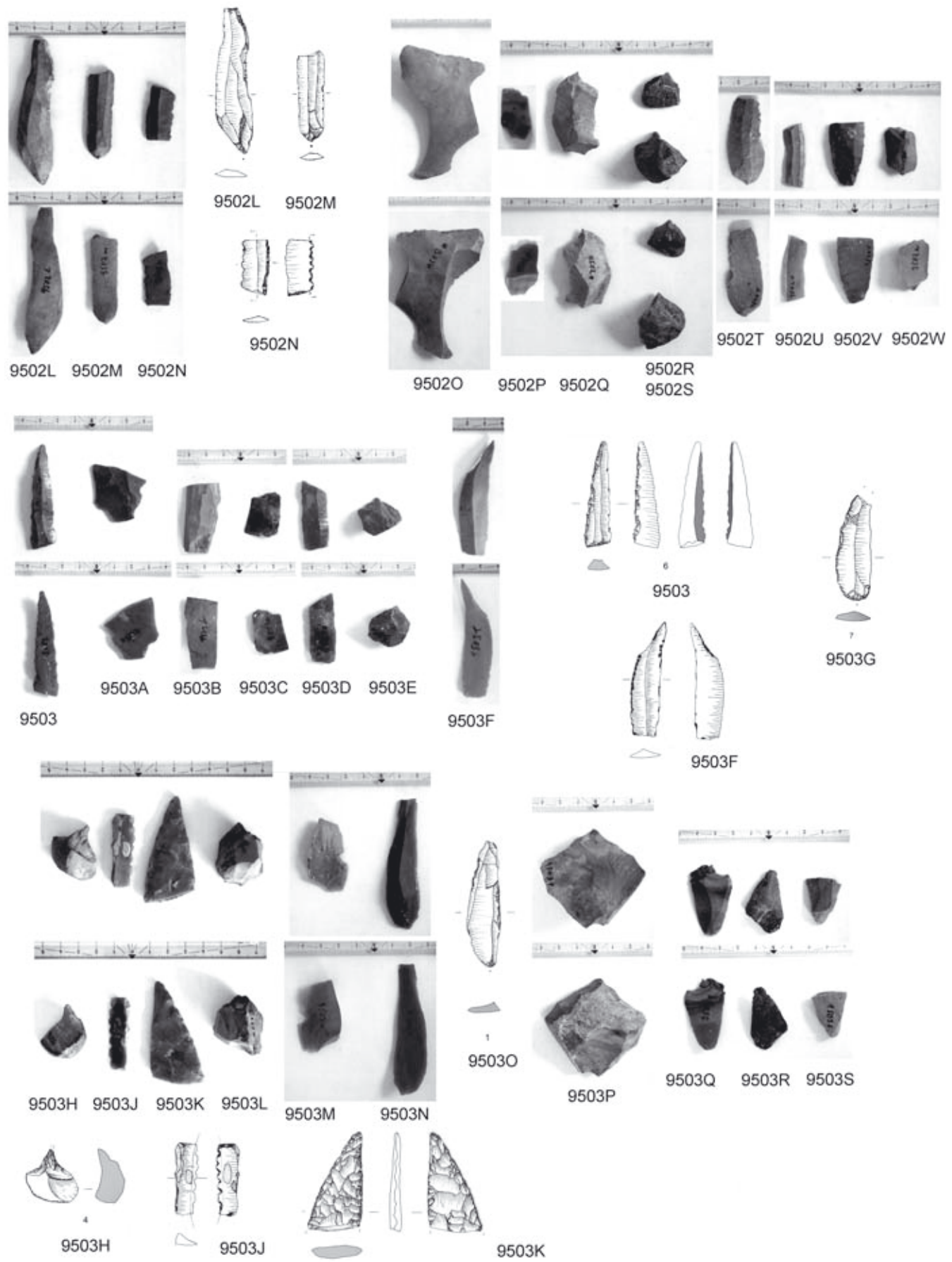

Abb. S33 Silices: nach Inv. Nr. geordnet

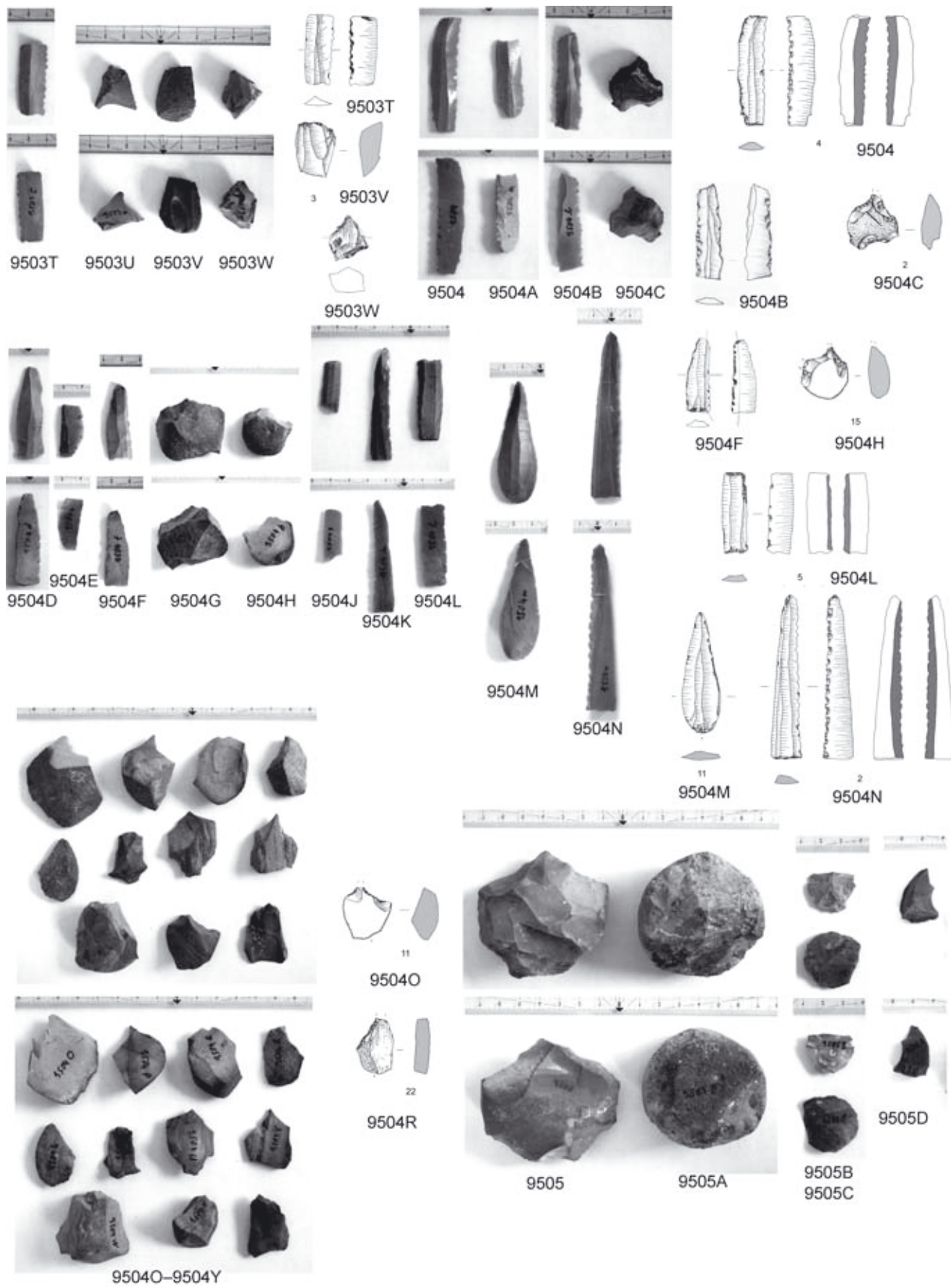

Abb. R1

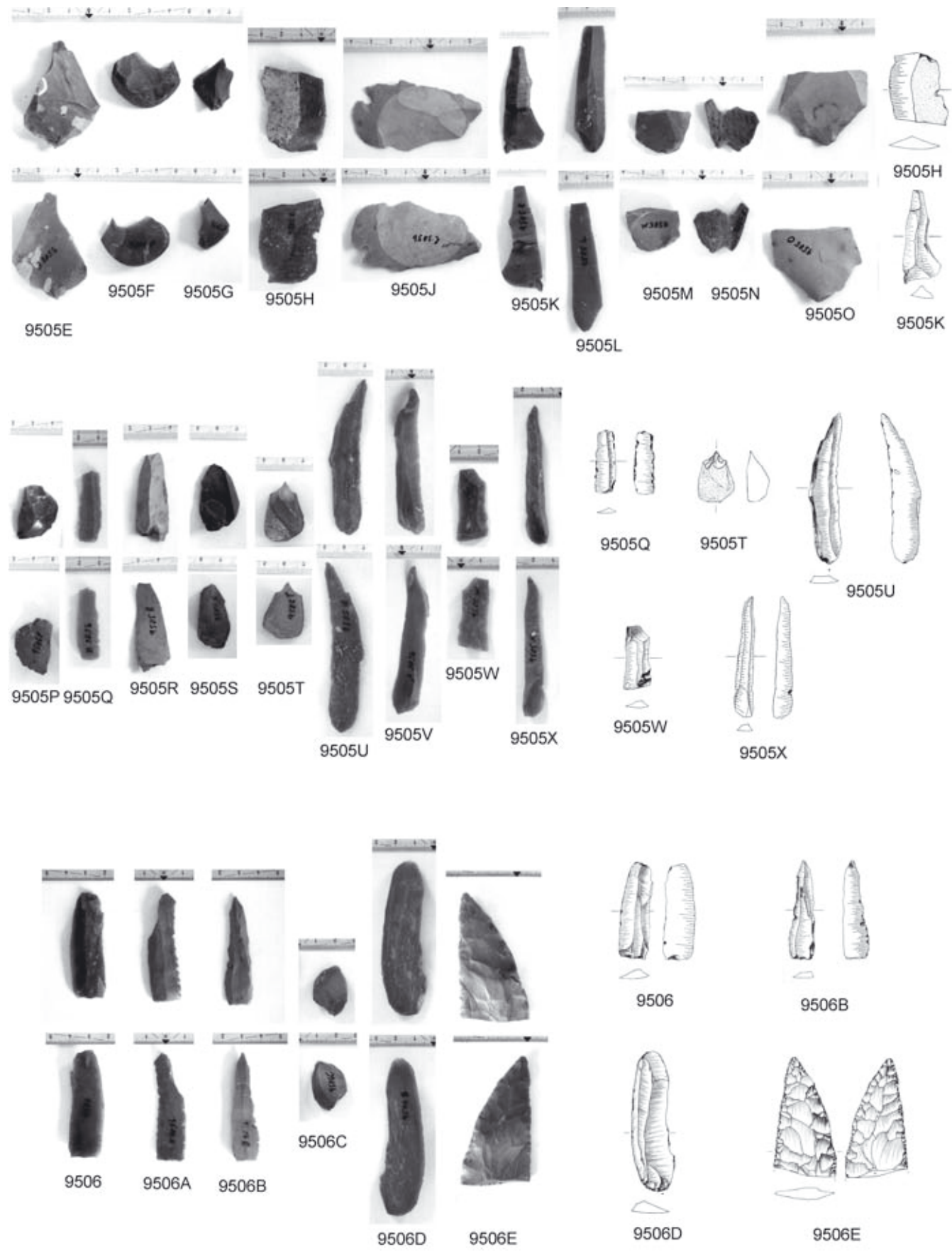

R/I, str. e/1, Rekonstruktion

O = Ocker/Rötel  
 S = Siegelmasse  
 K = Karneolstücke

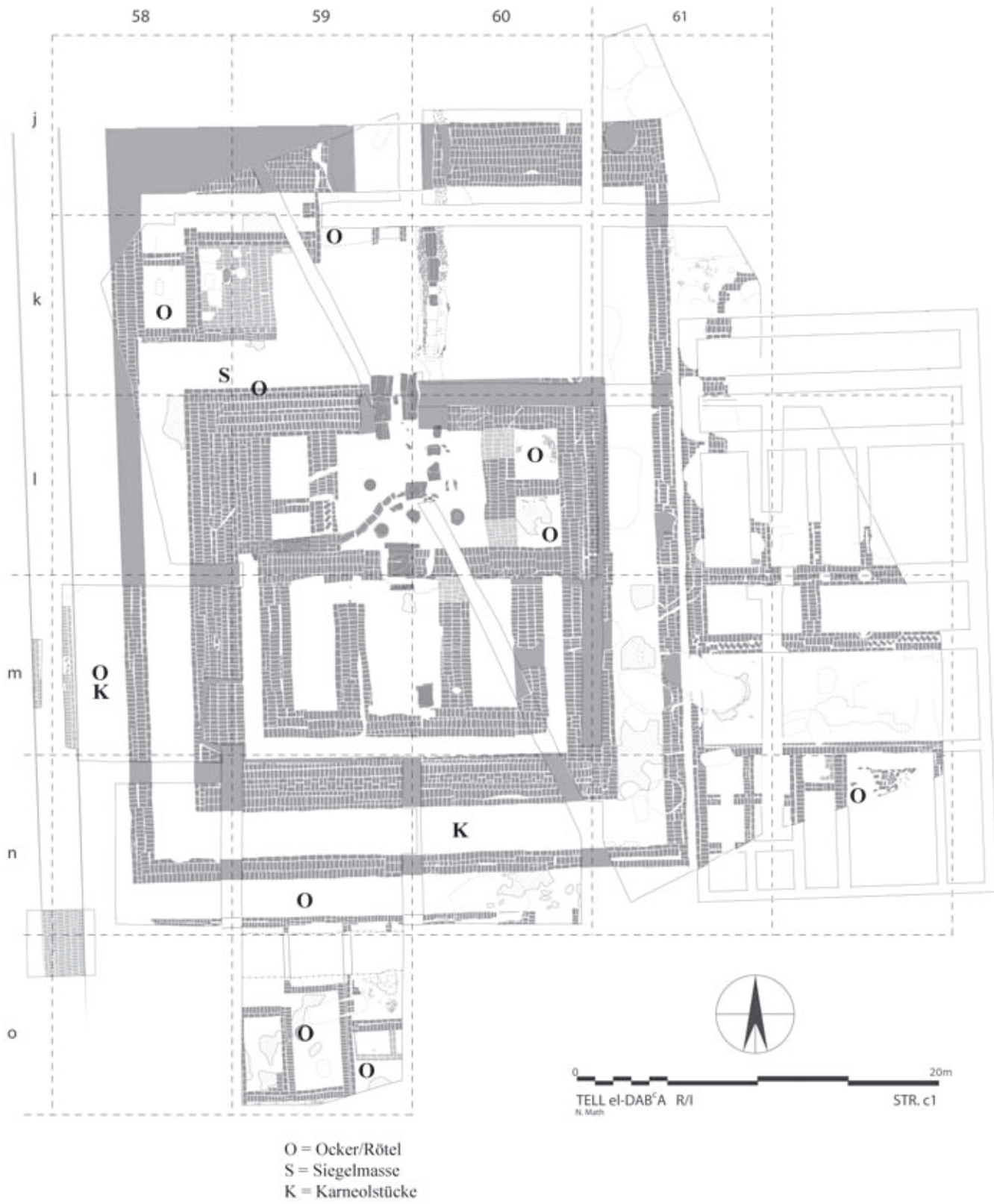
Abb. R2



O = Ocker/Rötel  
S = Siegelmasse  
K = Karneolstücke

R/I, str. e/2, Rekonstruktion

Abb. R3



R/I, str. e/3, Rekonstruktion

- O = Ocker/Rötzel
- S = Siegelmasse
- K = Karneolstücke



Ein allseitig abgeschliffenes Stück Rötzel aus L288 (e/3)

Abb. R4



O = Ocker/Rötel  
S = Siegelmasse  
K = Karneolstücke

R/I, str. e/4

Abb. R5

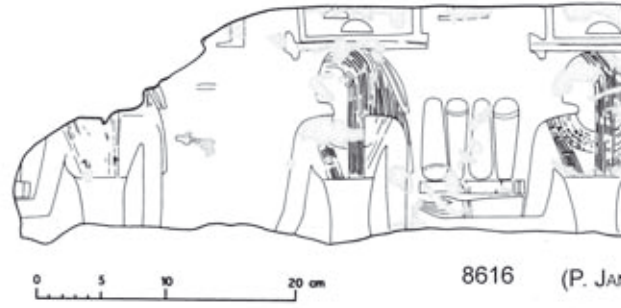

8616 (P. JANOSI, *Ä&L* 8, 66, Abb. 10)



8974I



8974J



8974K



8974La



8974Lb

j/59, Pl. 1, L226, Keller am Pylon, str. a



8974R



8975I



8974S



8975J



8975E



8975K



8610

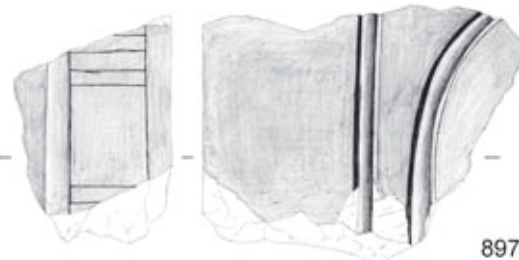

8976I



8976H

8610; 8976H-I: k/60, Pl. 0-1, aus rezentem Schutt / 8974R-S; 8975I-K: k/59, Pl. 0-1, L99, aus gestörter Füllung, (c-rezent)  
8975E: k/60, Pl. 1-2, L99, nördl. der Krone von M575



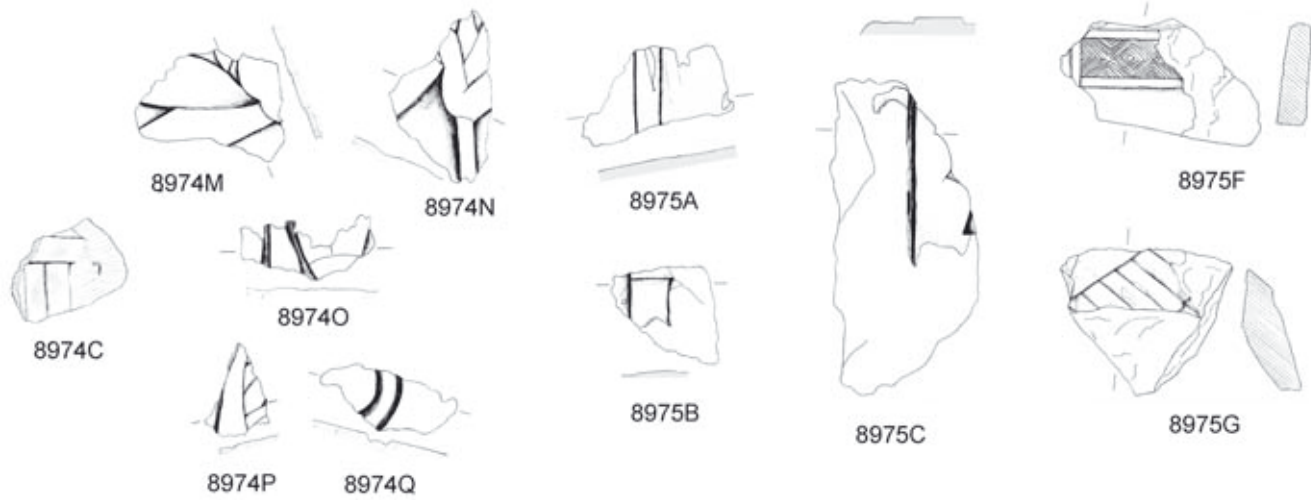

8974C: I/60, Pl. 0-1, L25 (aus gestörter lehmiger Füllung), c-d (-rezent)  
 8974M-Q: I/59, Pl. 0-1, L25, lehmiger Verbruch=Füllung Sh. Adam, (c-rezent)  
 8975A-C: I/59, Pl. 1, L25, bei der Türschwelle (c-rezent)  
 8975F-G: I/60, Pl. 1, L25, aus gestörtem O-Teil, lehmige Füllung. (c-rezent)



8974V: k/60, Pl. 0, L76 (Graben der Rinne, Steinsplitterschicht, H=4,20)  
 8974W-Z: I/59, Pl. 1, L76 (Füllung der Wasserleitung) str. ?

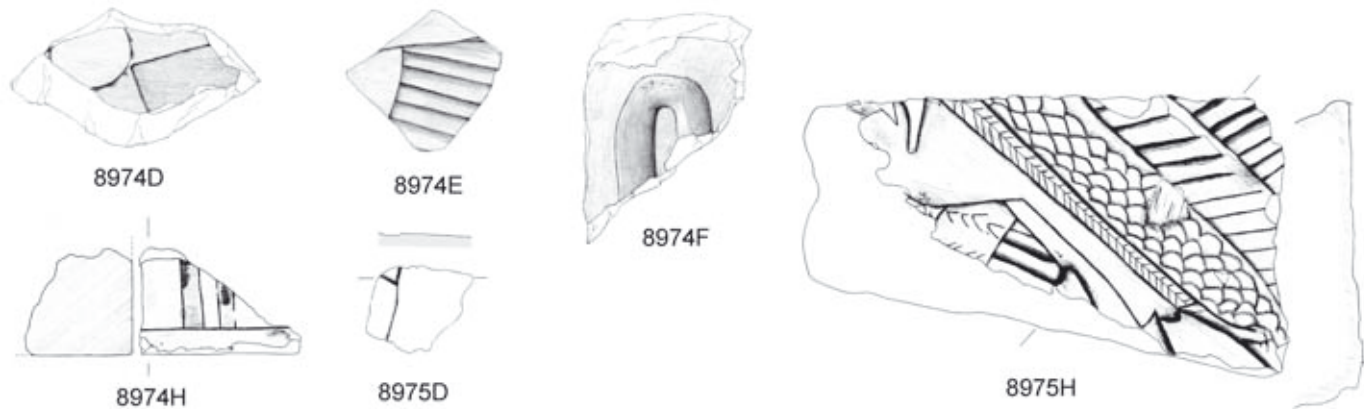

8974D-F: m/59/60, L85, Keller im Sanktuar, a  
 8974H: m/59, Pl. 0-1 (Füllung im Sanktuarbereich)  
 8975D: m/60, Pl. 0-1, aus Verbruch über den Mauerkronen des Mittelsanktuars (M686/M688); a-rezent  
 8975H: m/I-59, Profilstege, in kleiner Störung in M683 (Sanktuar-Frontmauer), H=413. a-rezent

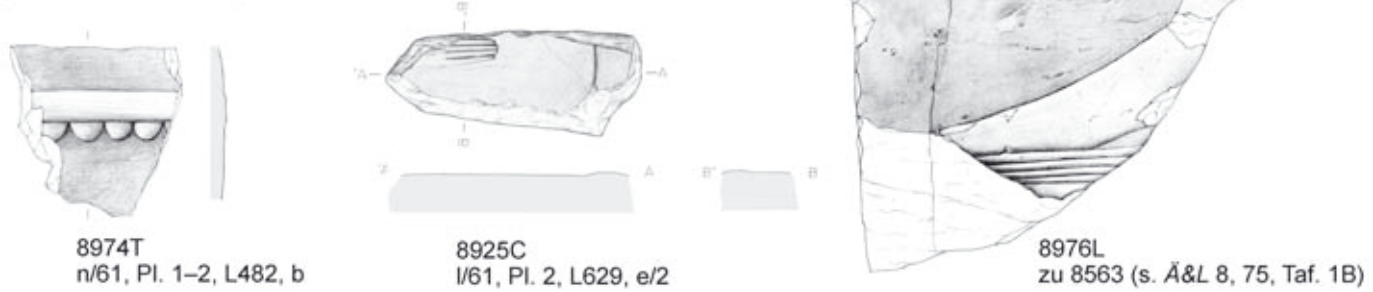

8974T  
 n/61, Pl. 1-2, L482, b

8925C  
 I/61, Pl. 2, L629, e/2

8976L  
 zu 8563 (s. *Ä&L* 8, 75, Taf. 1B)



Abb. K3 Relieffragmente: photographische Dokumentation



Abb. K4 Relieffragmente: photographische Dokumentation

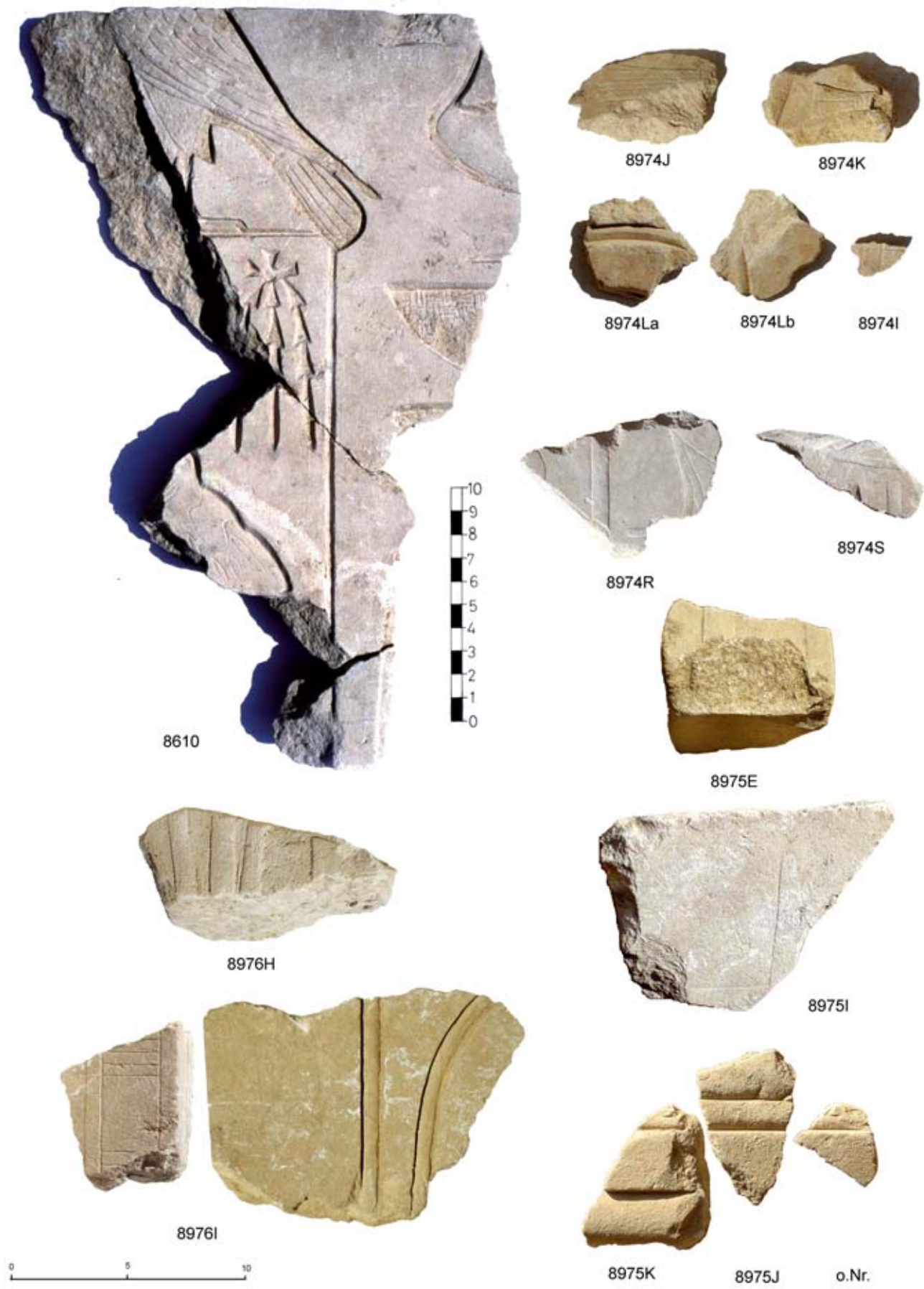

8975H

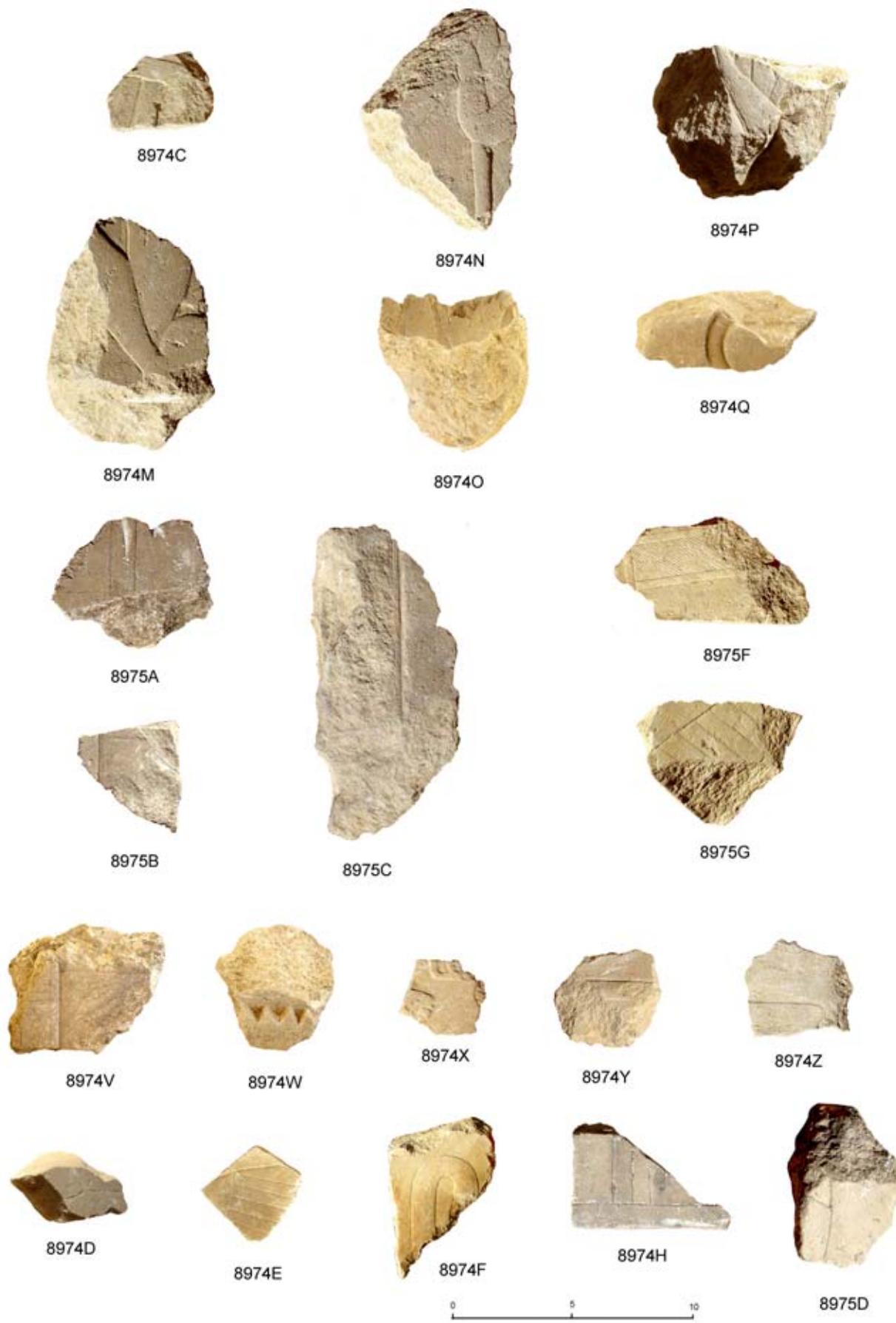

8974T



8915C



8976L



Abb. K5 Relieffragmente: photographische Dokumentation



Abb. K6 Die Fundlage der Reliefbruchstücke



a) Block vom Pyramidentempel Amenemhet I (MMA) mit 8974E

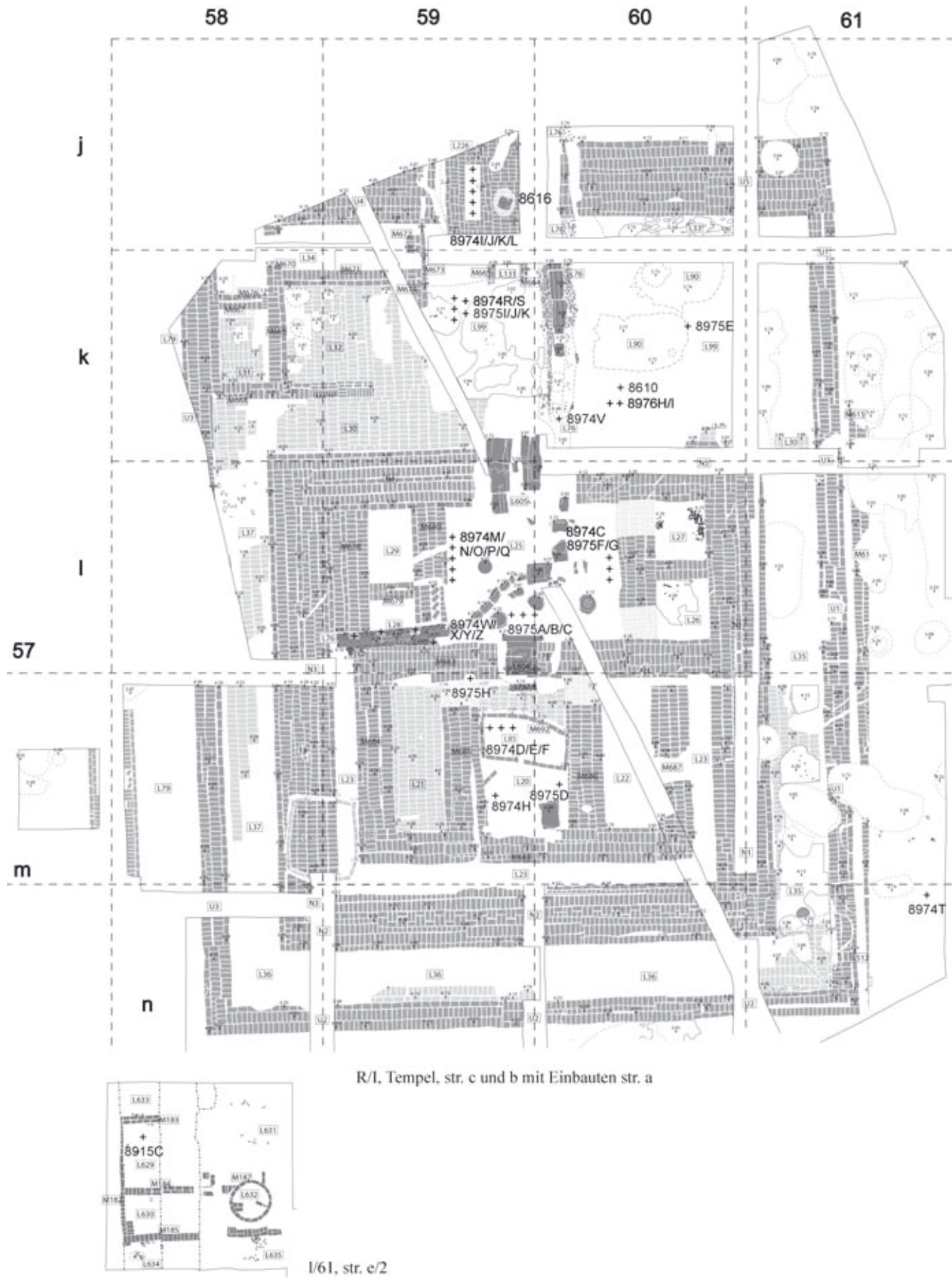

b) 8974F mit *s*-Hieroglyphe



c) 8974J mit *nh*-Hieroglyphe



d) 8974K mit *dj-nh* Hieroglyphen



e) Chapelle Blanche mit 8974R



f) 8974R mit Falken vom Totentempel Sesostris III in Dahshur, nach A. Oppenheim



g) 8974K mit *nh*-Zeichen aus dem Totentempel Sesostris III in Dahshur, nach A. Oppenheim

Abb. K7 Relieffragmente: Ergänzungen und Parallelen

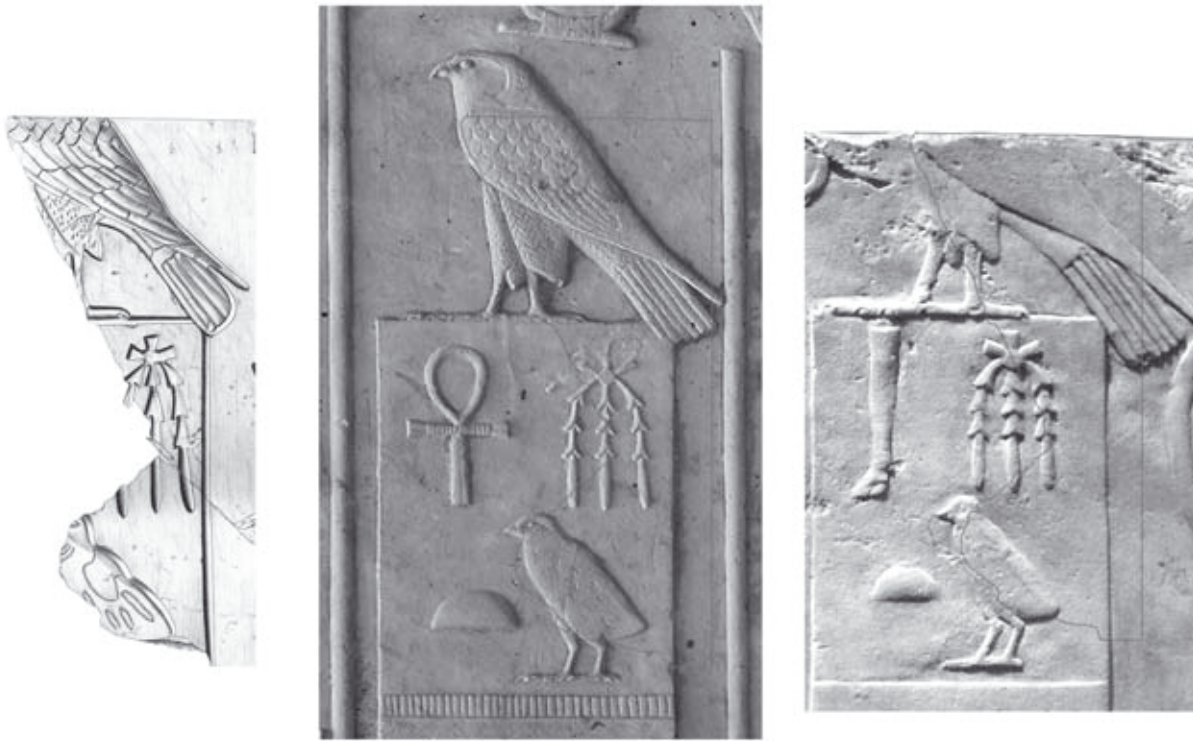

a) 8610 mit den Horusnamen Sesostris I und Amenemhet I (Chapelle Blanche; MMA)



8975H

b) Ein Falke vom Pyramidentempel Amenemhet I in Lisht (MMA) und von der Chapelle Blanche mit der skalierten Kontur des Bruchstücks 8975H

Abb. K8 Relieffragmente: Ergänzungen und Parallelen

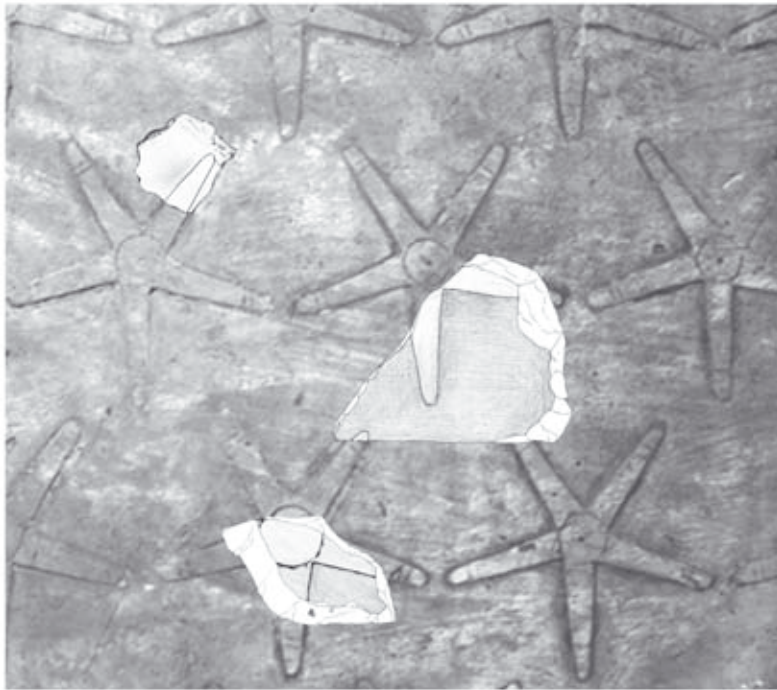

a) Chapelle Blanche mit 8975I, 8974Z und 8974D



d) Sema-tawj mit 8976H



e) 8974X mit Kartusche Amenemhet I'

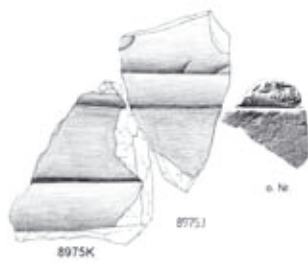

b) 8975J und 8975K



c) Chapelle Blanche mit 8975J



f) 8974La und 8976I

Abb. K9 Relieffragmente: Ergänzungen und Parallelen





Abb. K10 Teil einer Wand- oder Tordekoration Amenemhet II



a) TD 8349



0  
5  
10  
cm

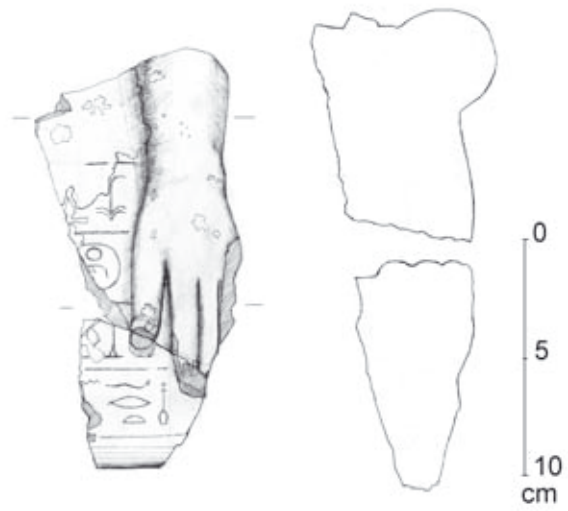

e) TD-LXX

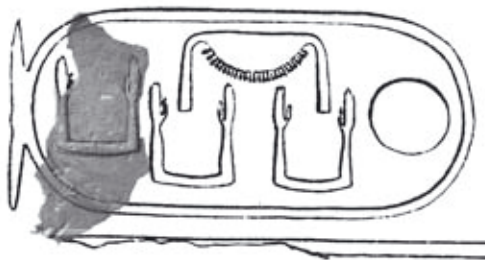

b) TD 8349 + PETRIE, *Memphis II*, Pl. 23 (scaliert)



c) Qubbet el-Hawa,  
Grab Sarenput II



d) Stele des Ichernofret,  
Berlin 1204

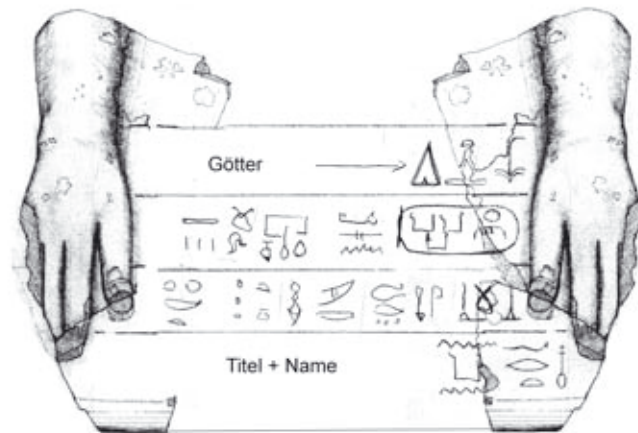

f) TD-LXX: hypothetische Rekonstruktion

Abb. K11 zusätzliche Hinweise auf Amenemhet II in der Region



8574

8575

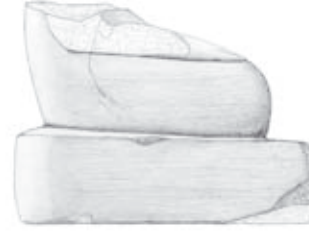

8576

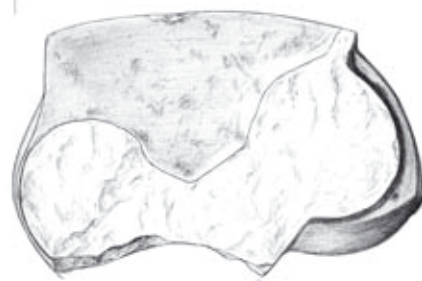

8609

Abb. K12



Abb. K13



8949H

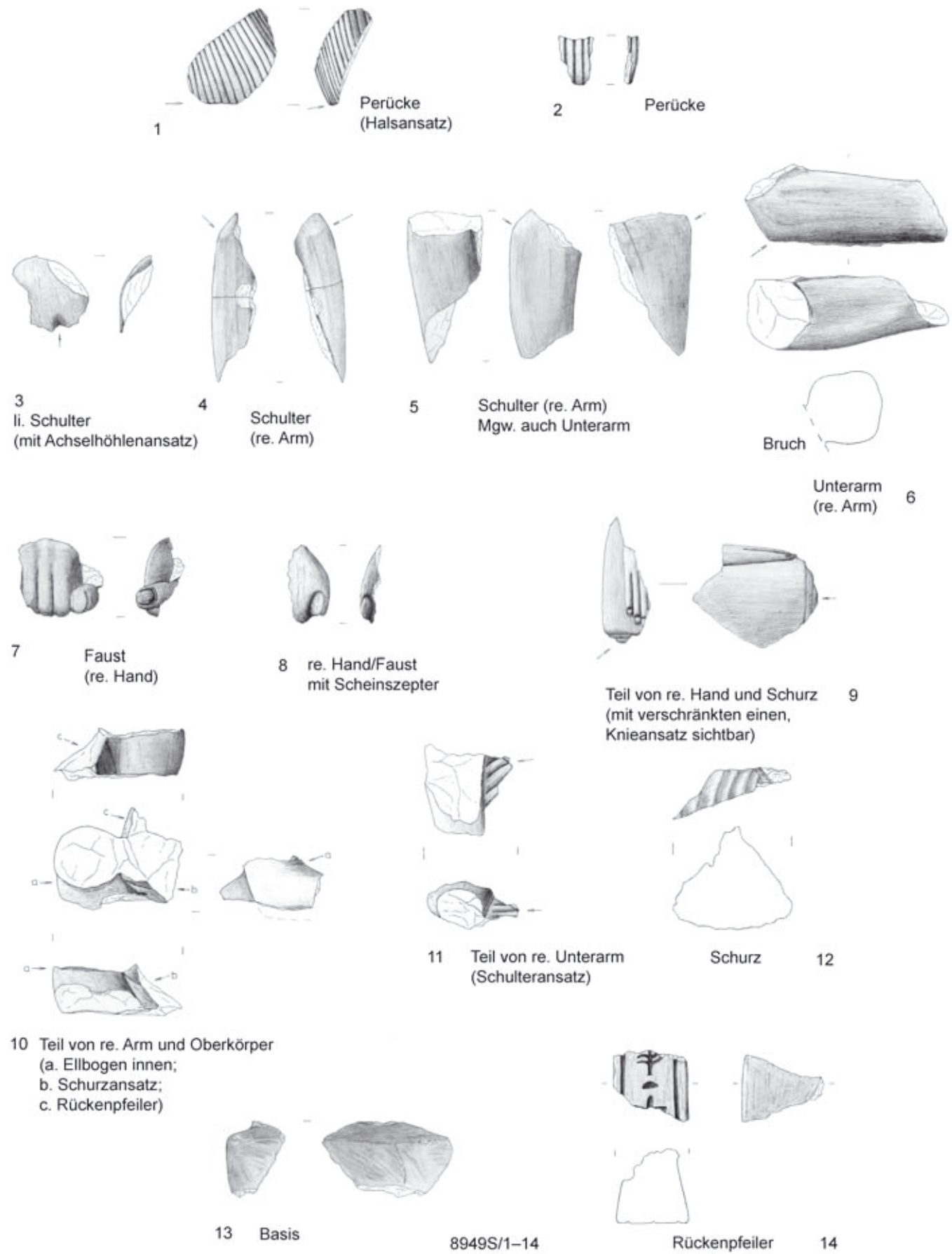
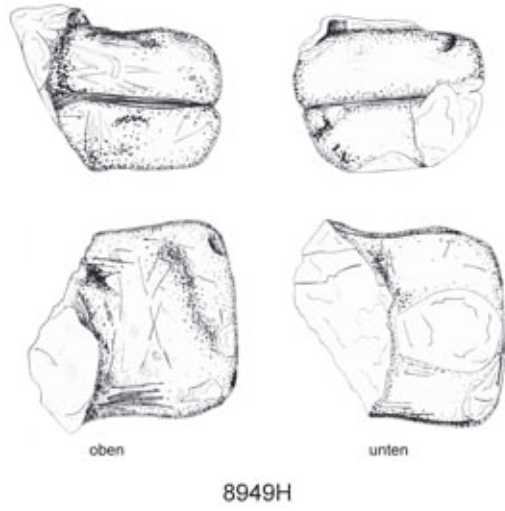

8974G

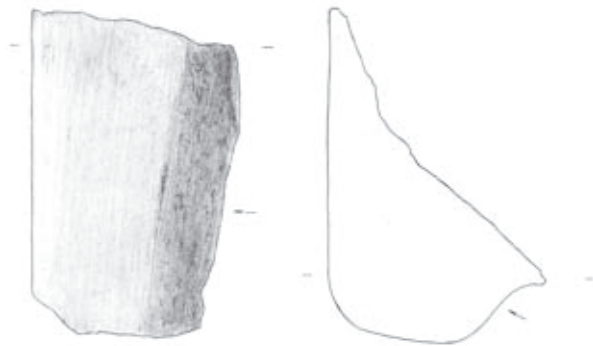

8976D



RÜCKENFEILER?  
(seitlich relativ grab)

8976E

Abb. K14



Abb. K15 Privatplastik: photographische Dokumentation



Abb. K16 Privatplastik: photographische Dokumentation

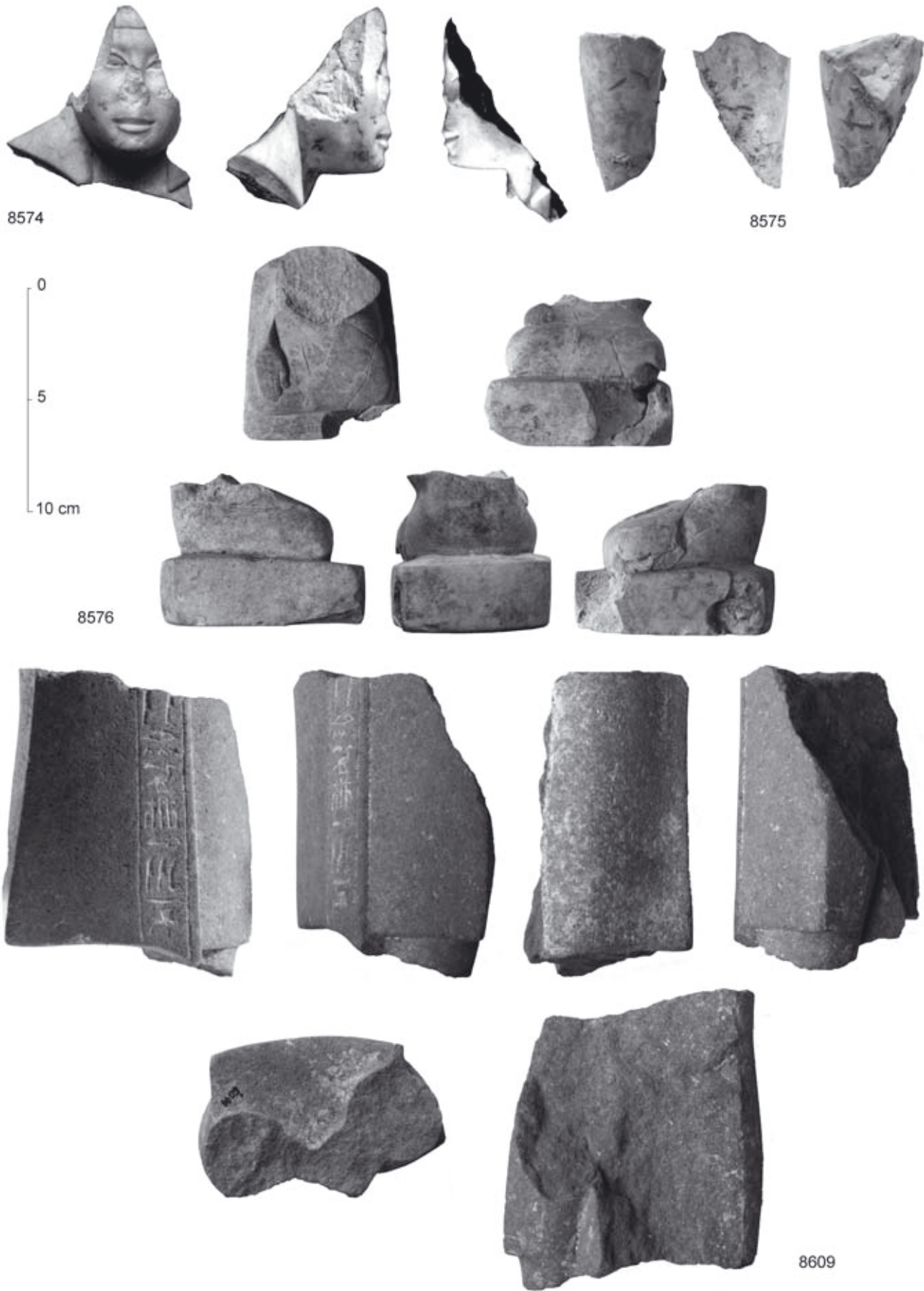

Abb. K17 Privatplastik: photographische Dokumentation





8574



8576



8609



8949S/7



Abb. K18 Privatplastik: photographische Dokumentation



Die Fundlage der Plastiken im Tempel (R/I, Tempel, str. c und b mit Einbauten str. a)

Abb. K19

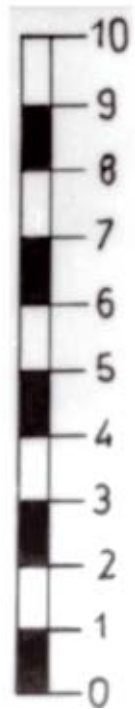
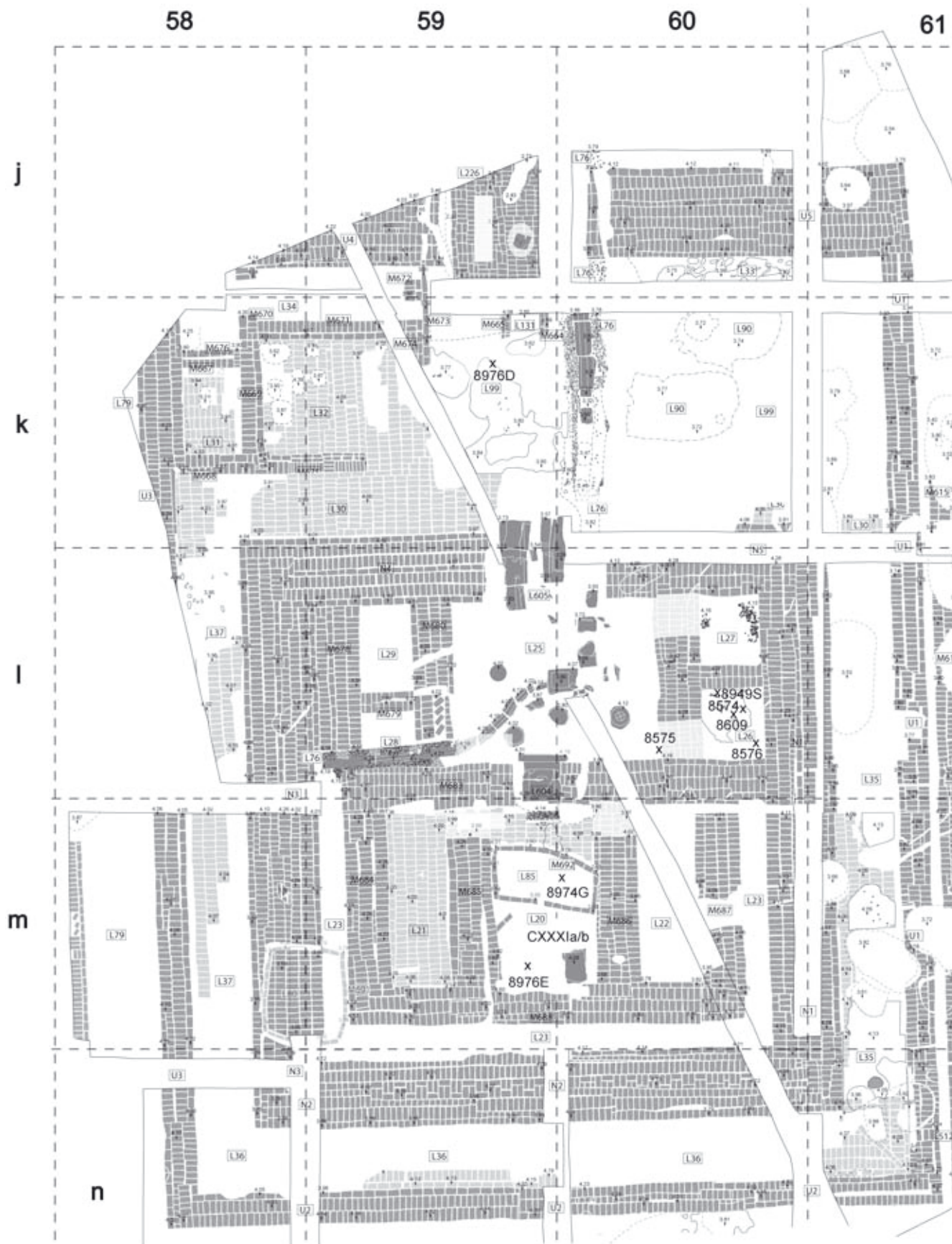
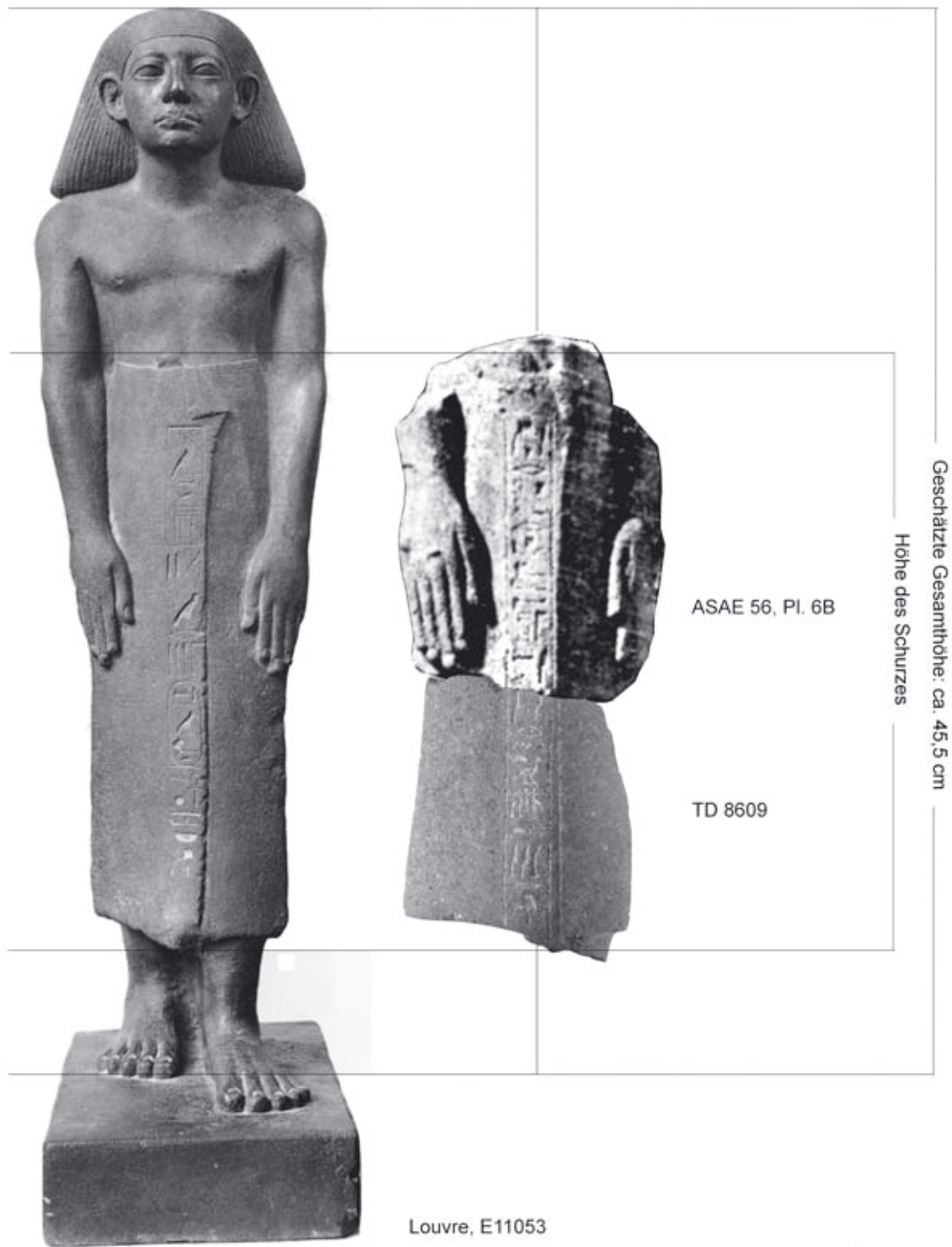

Die Statue Louvre E11053 und die Fragmente ASAE 56, Pl. 6B und TD 8609 auf die gleiche Schurzhöhe skaliert.

Abb. K20 TD 8609 mit ASAE 56, Pl. 6B (Sh. ADAM) und das Vergleichsstück Louvre E11053



Basis mit Füßen des *Jmny*, Paris, Privatbesitz

Die Bruchflächen der Statuenbasis (Paris, Privatbesitz) und TD 8609 übereinanderprojiziert

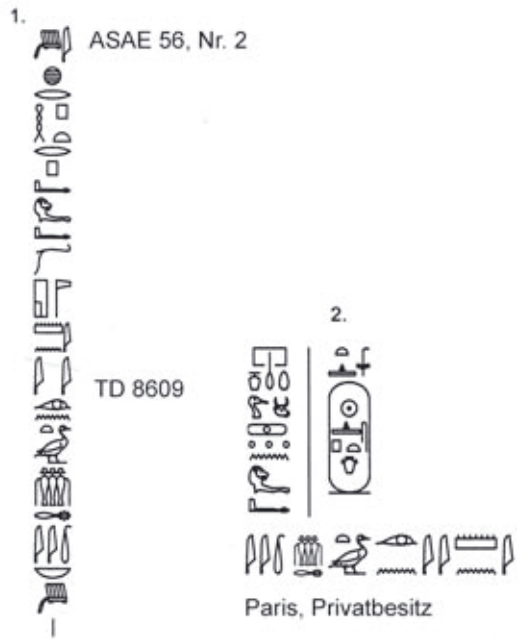

Die Inschriften auf den 3 Bruchstücken der Statue des *Jmny* (nach VERBOVSEK, *Tempelstatuen*)



Fig. 175 bis.

Statuenfragment aus der sog. Prinzessinnengalerie der Pyramide Sesostri III in Dahshur (DE MORGAN, *Fouilles de Dashour* 1894, 74)



a) Das Mittelsanktuar L20 mit dem Kalksteinblock in situ



A.—The middle Kingdom royal statue found in the central sanctuary of the temple.

b) Die Statue CXXXIa bei ihrer Auffindung durch Shehata Adam, ASAE 56, Pl. 6A



A.—The granite statue found at Ezbet Rushdi in December 1950.

c) Die Statue CXXXIb bei ihrer Auffindung durch Shehata Adam, ASAE 56, Pl. 13A

Abb. K22 Die Königsstatuen CXXXIa und CXXXIb



Abb. K23 Die Königsstatue CXXXIa (Tell Basta, Museum)



Abb. K24 Die Königsstatue CXXXIa, Details (Tell Basta, Museum)



Abb. K25 Die Königsstatuen CXXXIb (Tell Basta, SCA-Magazin)





Abb. K26 Die Königsstatuen CXXXIb Details (Tell Basta, SCA-Magazin)

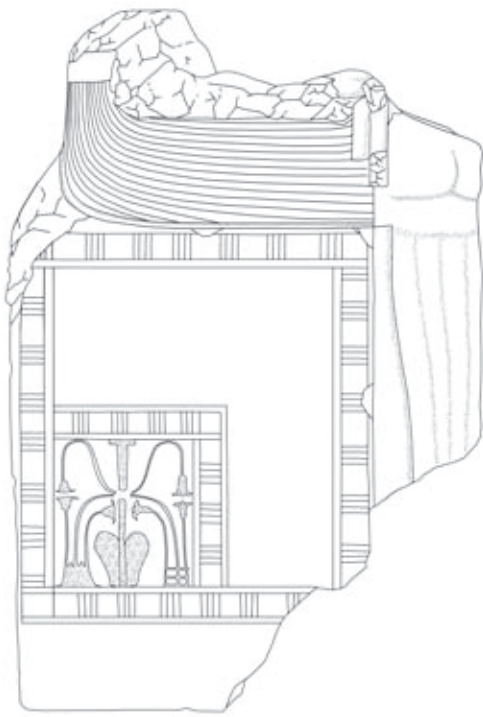

CXXXIa

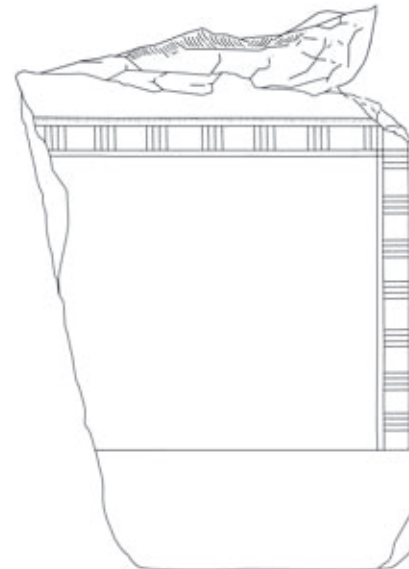
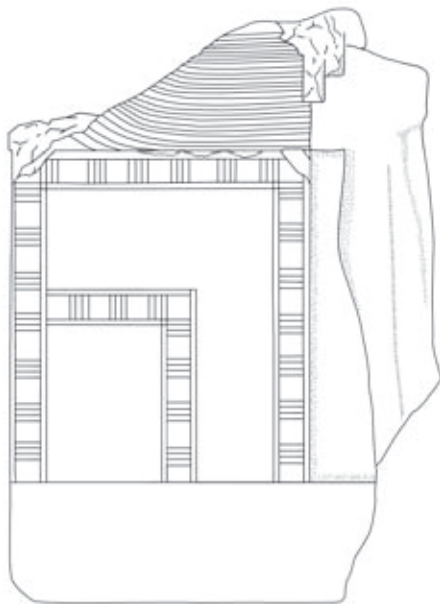

CXXXIb

Abb. K27 Die Statuen CXXXIa und CXXXIb: Dekorationselemente und Aufsicht (nach Photos; Zeichnung: N. Math)



M II (Deir el-Bahari; EVERS, *Staat I*, Taf. 10)



S I (Karnak; EVERS, *Staat I*, Taf. 18)

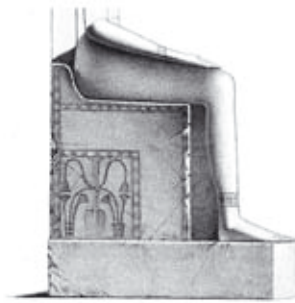

A III/IV (Berlin 1117; LD II, 120f)



A I (Khatana; TD I, Taf. 6A)



S I (Fayum?; MMA25.6, ARNOLD, *Statue*, fig. 3)



A V (Elephantine; MDAIK 44, Taf. 19a)



A I (Kiman Faris; BEM 2, 116, Pl. 5d)



S I (Abydos; Photo: V. Müller)



S I (?) CG 538



A I (?) JE 29212 (BEM 2, 114, Pl. 3c)

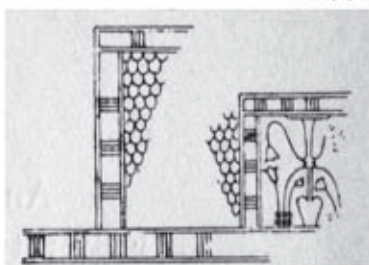

Frühe 12. Dyn. CG 389

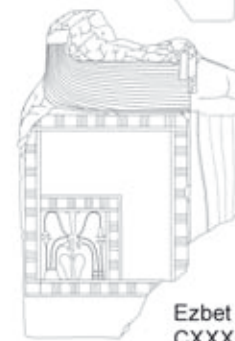

Ezbet Ruschdi, CXXXIa

Abb. K28 Das "Kleine Sema-Tawj", Überblick



a)



b)



c)



d)

Dyade Amenemhet I mit Amun, Karnak. a), c) nach M. SEIDEL, *Statuengruppen*, Taf. 22 a, b; b), d), nach H.G. EVERS, *Staat* I, 22, Abb. 4; II, Taf. 2/35.

Abb. K29 Statuengruppen: Vergleiche



a. et-Tôd, Tempelbezirk des Month (Dok. 34)



b. et-Tôd, Tempelbezirk des Month (Dok. 34)

Dyade Amenemhet I mit Sachmet, el-Tod. Nach M. SEIDEL, *Statuengruppen*, Taf. 25 a, b

Abb. K30 Statuengruppen: Vergleiche



a)

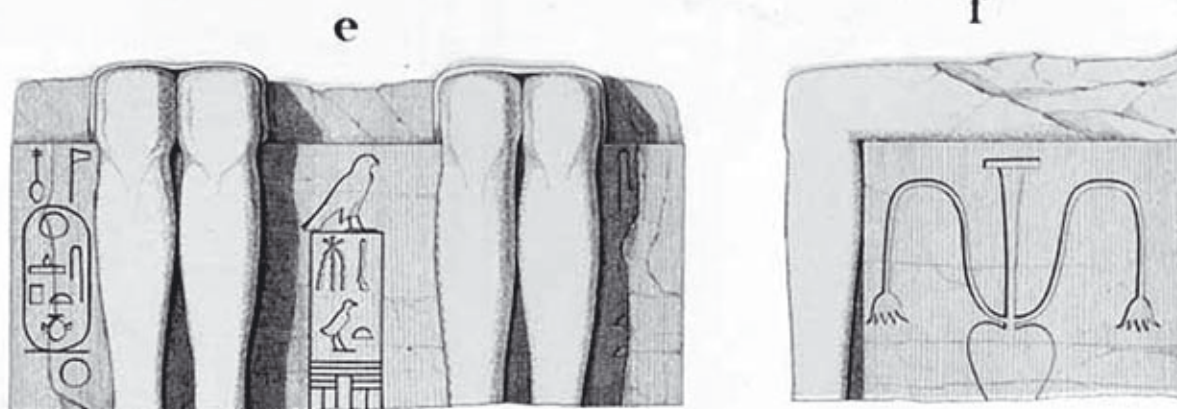

b)

Dyade Amenemhet I mit Bastet, Kiman Faris (Krokodilopolis); a) nach SOUROUZIAN, *BEM* 2, Pl. 5 a-d;  
b) nach *LD* II, Taf. 118 e, f

Abb. K31 Statuengruppen: Vergleiche

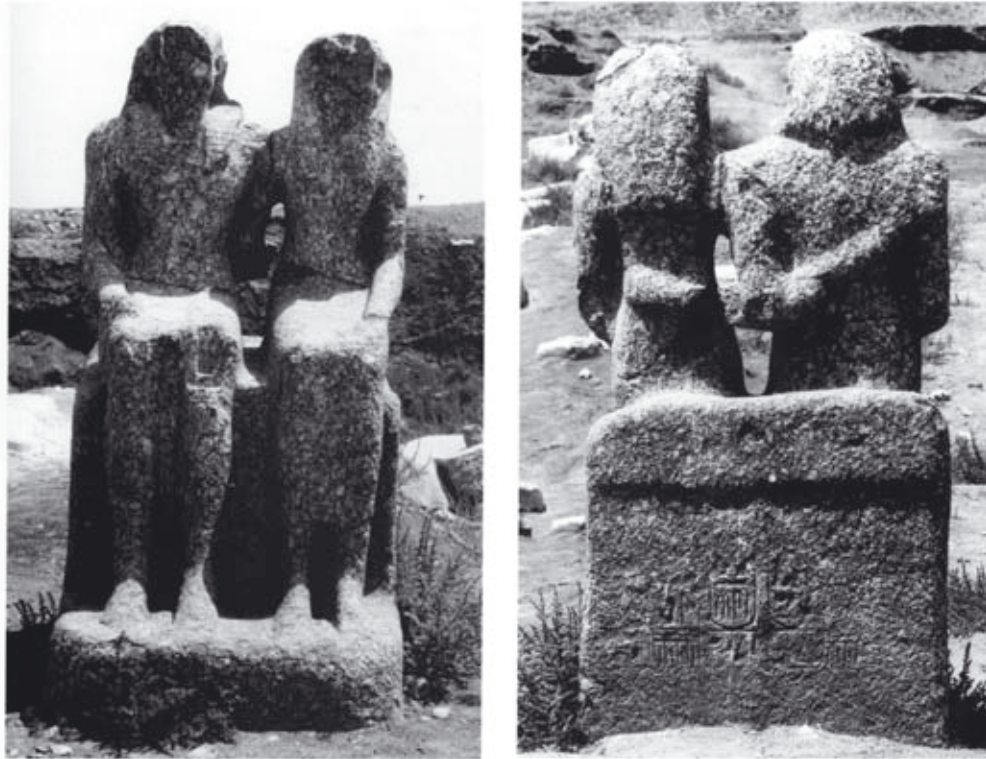

a) Dyade Ramses II (=Amenemhet I?) mit Wadjet (?), Buto. Nach SOUROUZIAN, *BEM* 2, Pl. 6



1)



2)

b) Dyade Sesostris I mit Isis, Abydos.  
1) nach SEIDEL, *Statuengruppen*, Taf. 26b;  
2) Photos V. Müller

Abb. K32 Statuengruppen: Vergleiche

